

LITTLE WONDER®

OWNER'S MANUAL and SAFETY INSTRUCTIONS

for *Single Sided Gasoline Hedge Trimmers*

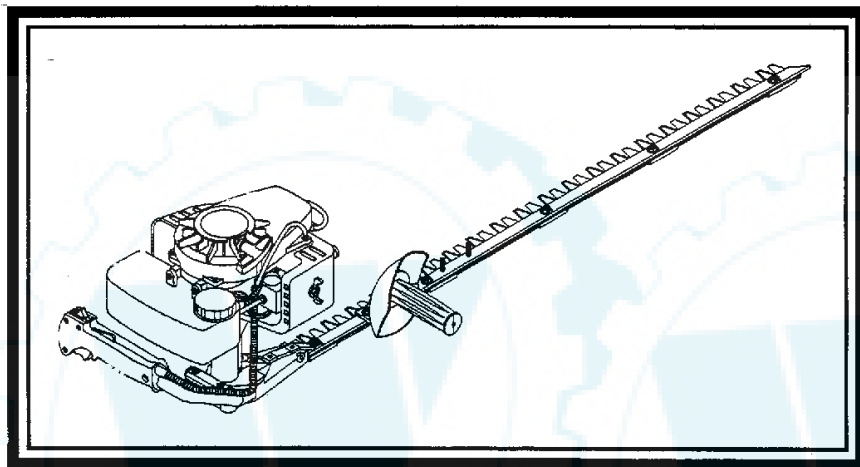

Models

2230S - 30 inch

2242S - 42 inch

and for *Double Sided Gasoline Hedge Trimmers*

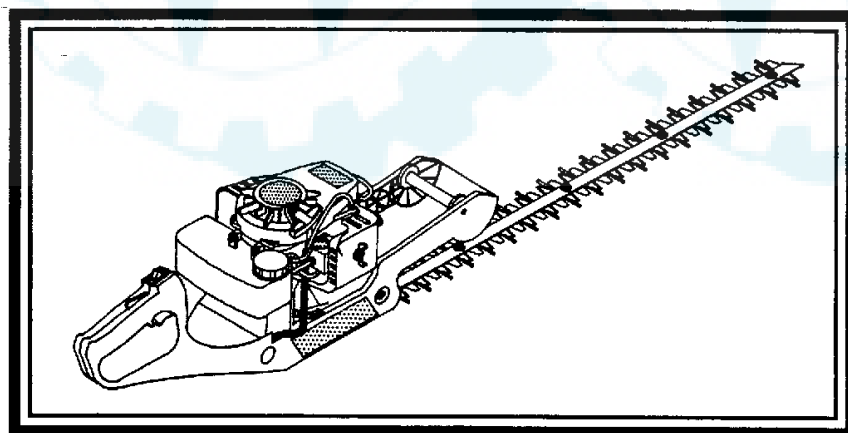

Models

2216D - 16 inch

2224D - 24 inch

2230D - 30 inch

5 YEAR LIMITED SERVICE & WARRANTY POLICY
FOR GASOLINE HEDGE TRIMMERS

All **Little Wonder** Gasoline Hedge Trimmers are guaranteed against defects in material and workmanship for a period of FIVE YEARS from date of purchase, when used for RESIDENTIAL SERVICE, or COMMERCIAL SERVICE. Any **Little Wonder** Gasoline Hedge Trimmer or part found to be defective within the warranty period is to be returned to any registered Little Wonder Dealer.

Engines for all gasoline powered products are warranted separately by the engine manufacture for a period of a year. Therefore, there are no warranties made, expressed or implied, for engines for gasoline powered products by **Little Wonder**.

Transportation charges for parts and units submitted for replacement under this warranty must be borne by the purchaser.

THIS WARRANTY shall not be effective if the product has been subject to misuse, negligence or accident, used in cutting hedges or shrubs greater than 1" in diameter, used to cut foreign objects such as wire, rocks, or fences, or if the product has been repaired or altered outside of our Southampton factory in any respect which affects its condition or operation.

LITTLE WONDER shall not be liable for any special indirect or consequential damages arising from defective equipment. Any implied warranty, including merchantability of fitness for a particular purpose, shall not extend beyond the written warranty period.

THIS WARRANTY shall only be effective if the enclosed Warranty/Registration card is properly filled out and returned to **Little Wonder**, Div. of Schiller-Pfeiffer, Inc. at time of purchase.

⚠ Warning: The Engine Exhaust from this product contains chemicals known to the State of California to cause cancer, birth defects or other reproductive harm.

LITTLE WONDER®

DIVISION OF SCHILLER-PFEIFFER, INCORPORATED
1028 STREET ROAD, P.O. BOX 38
SOUTHAMPTON, PA 18966
PHONE 215-357-5110 • FAX 215-357-8045

B. SERVICE INFORMATION

CUTTER BAR

Contact your local **Little Wonder** dealer.

ENGINE

Contact an authorized Echo dealer. Dealers are listed in the Yellow Pages under "Lawn and Garden Equipment Supplies", "Lawn Maintenance" or "Lawn Mowers".

C. SPECIAL SAFETY INFORMATION

▲ WARNING DANGER ▲
ATTENTION; THIS SYMBOL POINTS OUT OUR IMPORTANT SAFETY INSTRUCTIONS.
WHEN YOU SEE THIS SYMBOL, **▲** HEED IT'S WARNING!!
STAY ALERT!!

▲ WARNING DANGER ▲
TO REDUCE THE POTENTIAL FOR ACCIDENTS, COMPLY WITH THE SAFETY INSTRUCTIONS IN THIS MANUAL.
FAILURE TO COMPLY MAY RESULT IN SERIOUS PERSONAL INJURY AND OR EQUIPMENT AND PROPERTY DAMAGE.

▲ Warning: The Engine Exhaust from this product contains chemicals known to the State of California to cause cancer, birth defects or other reproductive harm.

II. SAFETY AND WARNINGS

▲ WARNING DANGER ▲
IMPROPER USE OR CARE OF THIS TRIMMER, OR FAILURE TO WEAR PROPER PROTECTION CAN RESULT IN SERIOUS INJURY.
READ AND UNDERSTAND THE RULES FOR SAFE OPERATION AND ALL INSTRUCTIONS IN THIS MANUAL.
WEAR HEARING PROTECTION.

A. SAFETY DECALS

An important part of the safety system incorporated in this trimmer are the warning and informational decals found on various parts of the trimmer. These decals must be replaced in time due to abrasion, etc. It is your responsibility to replace the decals when they become hard to read. The location of these decals and their part numbers for ordering are shown below.

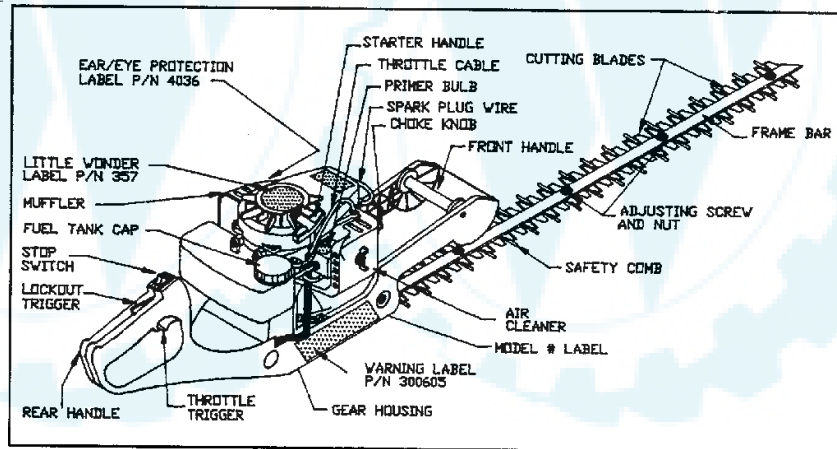
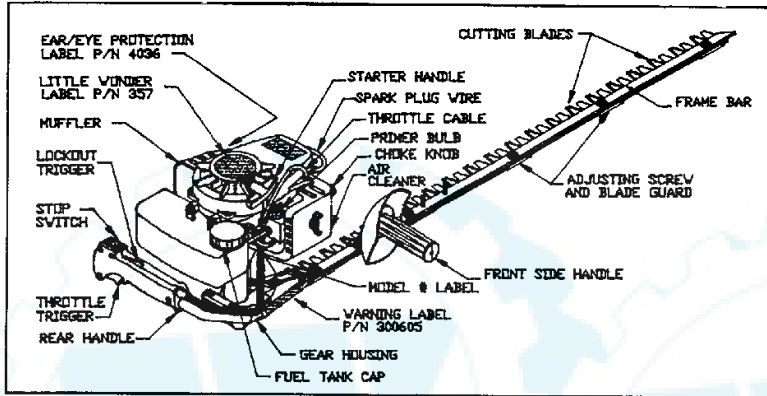

B. SAFETY DECAL IDENTIFICATION

	WARNING	P/N 300605
<ul style="list-style-type: none"> ■ READ AND UNDERSTAND OPERATOR'S MANUAL BEFORE USING! KEEP IN A SAFE PLACE! ■ KEEP BOTH HANDS ON HANDLES AND AWAY FROM BLADES! ■ KEEP A SURE FOOTING AND NEVER OVERREACH! WHEN REACHING HIGH, STAND ONLY ON A STABLE SUPPORT, AND NEVER ON THE TOP OF A LADDER! ■ BLADES COAST AFTER THROTTLE TRIGGER IS RELEASED OR ENGINE IS SWITCHED OFF! ■ NEVER OPERATE WITHOUT GUARDS, HANDLES, AND SAFETY DEVICES IN PLACE! 		

P/N 300605
Warning Label



P/N 4036
Ear and Eye
Protection Label

▲ C. GENERAL SAFETY RULES

1. Read and understand the owner's manual. Pay particular attention to all sections regarding safety.
2. Always keep a firm grip on both handles while the blades are moving and/or the engine is running. On Double Sided units one hand grasps the front handle, while the other hand grasps the rear handle. On Single Sided units the right hand grasps the front side handle and the left hand grasps the rear handle. **BE AWARE!!** The blades coast after throttle trigger is released or engine is switched off. Make sure blades have come to a complete stop and engine is off before releasing a handle.
3. Maintain a firm footing and good balance, do not overreach while trimming. Before you start to trim, check the work area for obstacles that might cause you to lose your footing, balance or control of the machine.
4. Keep area clear of children, pets, and bystanders.

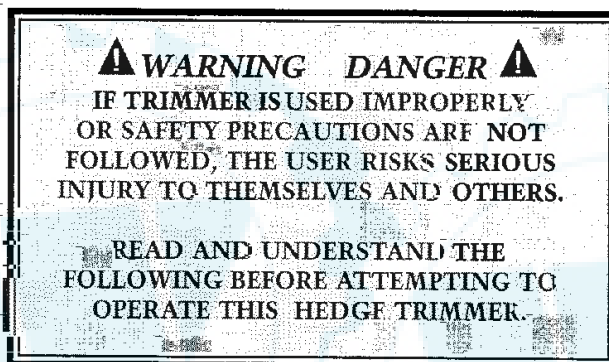

▲ D. WARNINGS — DON'TS

Don't use trimmer with one hand, keep both hands on handles with fingers and thumbs encircling the handles, while blades are moving, and engine is running.

Don't overreach or stand on unstable support. Do not stand on the top of a ladder while trimming. Use proper equipment for reaching higher heights. Keep a good footing at all times.

Don't ever grasp cutting blades for any reason.

Don't attempt to clear cut material while blades are moving, and the engine is running. Never try to remove jammed material before switching the engine off and making sure the blades have stopped completely.

Don't over-ride safety features.

Don't allow children or incapable people to operate this trimmer.

Don't operate this hedge trimmer while under the influence of alcohol or drugs.

Don't attempt to repair this hedge trimmer. Have repairs made by a qualified dealer or repairman. See that only original **Little Wonder** parts are used.

▲ E. WARNINGS — DO'S

Always read and follow all instructions.

Always stay alert. Watch what you are doing and use common sense. Do not operate unit when fatigued.

Always dress properly. Do not wear loose clothing or jewelry, they might get caught in moving parts. Use sturdy proper fitting, non-slip gloves. Gloves reduce the transmission of vibration to your hands. Prolonged exposure to vibration can cause numbness and other ailments. Wear non-skid foot wear to ensure secure and proper footing.

Always wear ear and eye protection. Eye protection must meet ANSI Z 87.1. To avoid hearing damage we recommend hearing protection be worn whenever using the equipment.

Always keep both hands on both handles when trimmer is running. Severe injuries can result if you try to use the hedge trimmer with only one hand or with an insecure grip.

Always keep children, pets, and incapable persons away.

Always use trimmer properly. Cut only types and size of growth described in the Trimming section of this manual. Overloading or abusing your hedge trimmer can cause premature failure and can result in injury. Use common sense.

Always keep a safe distance between two or more operators when working together simultaneously.

Always inspect your unit before each use and ensure that all handles, guards, safety devices and fasteners are secure, operating, and in place.

Always maintain and examine your trimmer with care. Follow maintenance instructions given in manual.

Always store trimmer in a sheltered area (a dry place) not accessible to children. The hedge trimmer as well as fuel should not be stored in a house.

▲ F. ENGINE/FUEL WARNINGS—DON'TS

▲ WARNING DANGER ▲
HANDLE FUEL WITH CARE, IT IS
HIGHLY FLAMMABLE. FUELING A
HOT ENGINE OR NEAR AN IGNITION
SOURCE CAN CAUSE A FIRE AND
RESULT IN SERIOUS PERSONAL INJURY
AND/OR PROPERTY DAMAGE.

Don't fuel, refuel or check fuel while smoking or near an open flame or other ignition source. Stop engine and be sure it is cool before refueling.

Don't leave the engine running while the trimmer is unattended. Stop engine before putting the trimmer down or while transporting from one place to another.

Don't start, run this trimmer indoors, or in an improperly ventilated area as poisonous carbon monoxide and other gasses are emitted.

Don't run engine when electrical system causes spark outside the cylinder. During periodical checks of the spark plug, keep plug a safe distance from cylinder to avoid burning of evaporated fuel from cylinder.

Don't check for spark with spark plug or plug wire removed and grounded. Use an approved tester. Sparks can ignite fumes.

Don't crank engine with spark plug removed. If the engine is flooded, open the choke (push choke knob in) and pull recoil until engine starts. If this fails read and follow section IV. E. of this manual.

Don't run engine when the odor of gasoline is present or other explosive conditions exist.

Don't operate the unit if gasoline is spilled. Clean up spill completely before starting engine.

Don't refuel indoors or in an improperly ventilated area.

Don't operate your trimmer if there is an accumulation of debris around the muffler, and cooling fins.

Don't touch hot mufflers, cylinders or cooling fins as contact may cause serious burns.

▲ G. ENGINE/FUEL WARNINGS—DO'S

Always use fresh gasoline in the fuel mixture. Stale gasoline can cause leakage.

Always pull starter cord slowly until resistance is felt. Then pull cord rapidly to avoid kickback and prevent arm or hand injury.

Always operate engine with spark arrestor installed and operating properly. The use of spark arrestor mufflers is required by law in the state of California (Section 4442 of the California Public Resources Code), as well as in other states or municipalities. Federal laws apply on federal lands.

III. ASSEMBLY INSTRUCTIONS

⚠ WARNING DANGER ⚠
BLADES ARE EXTREMELY SHARP.
TO AVOID INJURY WHEN
UNPACKING THE HEDGE
TRIMMER, DO NOT GRASP
THE BLADES.

For Double Sided Models

Your **Little Wonder** hedge trimmer has been assembled for you at the factory. Before operating be sure all fasteners are secure, and all guards and safety devices are in place and operating properly.

For Single Sided Models

1. Remove the cutter bar assembly, the engine with handle and throttle assembly, the side handle, and hardware bag from their boxes.

The hardware bag consists of the following items:

P/N	Description	Qty
972	1/4-20 Lock Nut	2
300102	Handle Support Channel	2
300113	Spacer Tube	2
300111	Shock Absorber	4
300112	Support Plate	1
300505	1/4-20 x 2 1/2 Bolt	2
3036-B	1/4-28 Flange Locknut	2

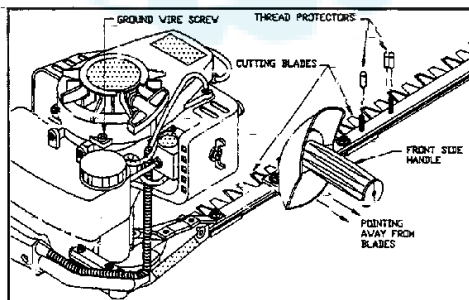

2. Place the front side handle over the two 1/4-28 studs protruding from the frame bar in front of the gear housing. The handle grip **must** be pointing away from the cutting blades as illustrated below, left. On Model 2230S use the set of studs which places the handle in the most comfortable position for you. Place the thread protectors over the set of studs that you choose not to use at this time to protect the threads. Secure the handle in place using two 1/4-28 flange locking nuts provided. The nuts should be tightened enough to keep the handle from moving but not so tight as to crush the plastic.

⚠ WARNING DANGER ⚠
IMPROPER ASSEMBLY OF THIS
TRIMMER CAN RESULT IN
SERIOUS INJURY. MAKE SURE TO
FOLLOW ALL INSTRUCTIONS
CAREFULLY.

IF YOU HAVE ANY QUESTIONS,
CONTACT YOUR LOCAL DEALER
OR OUR FACTORY AT
(215) 357-5110

3. Install the engine to the hedge trimmer by first aligning the hex drive on the trimmer gear housing with the hex socket in the engine. Slide the engine over the 1" diameter stem containing the hex drive on the gear housing until it is seated all the way down on the gear housing (see illustration below).

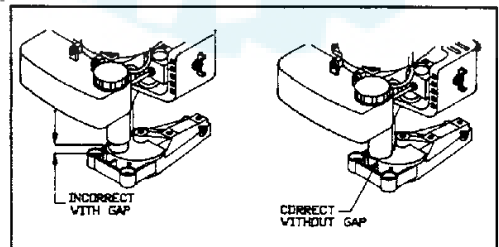

4. Press shock absorbers into sockets on the gear housing followed by the spacer tubes. Secure handle and tubing support channel, spacer, and bracket with the 1/4-20 hex bolts and locking nuts supplied (see illustration below).

5.

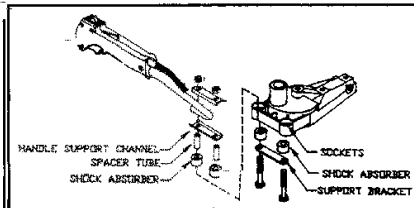

With the stop switch in the stop position, engine not running, check the throttle for proper operation. Grasp rear handle with left hand, depressing the lockout trigger, squeeze the throttle trigger until it stops when the carburetor lever hits the carburetor case. Release the throttle trigger and make sure the throttle returns to the idle position, when the carburetor lever rests on the idle screw. Throttle movement should be smooth and unobstructed.

BREAK-IN PROCEDURE

There are no special requirements for engine break-in. After normal operation and two (2) tanks of fuel, engine break-in is complete.

If adjustments are necessary, follow Special Carburetor Adjustment Procedures on this supplementary Operator's Information Sheet. All other adjustments and maintenance procedures are in the complete Operator's Manual.

IV. OPERATION

▲ WARNING DANGER ▲
 THE OPERATOR OF THIS
 HEDGE TRIMMER IS
 RESPONSIBLE FOR ACCIDENTS
 OR HAZARDS OCCURRING TO
 HIMSELF, OTHER PEOPLE OR
 THEIR PROPERTY.

A. FUEL MIXTURE

▲ WARNING DANGER ▲
 FUEL IS EXTREMELY FLAMMABLE.
 HANDLE IT WITH CARE. KEEP
 AWAY FROM IGNITION SOURCES.
 DO NOT SMOKE WHILE FUELING
 YOUR EQUIPMENT.

Your Little Wonder hedge trimmer is powered by an Echo Model SV-4B(H) Type IE two stroke, air cooled engine which requires a fuel mixture of gasoline and lubricating oil.

IMPORTANT ENGINE INFORMATION

This unit is certified to operate on approved two-stroke fuel (a mixture of 2-stroke oil and gasoline/gasohol).

FUEL STATEMENT

Gasoline - Use 89 Octane [$\frac{91}{100}$] gasoline or gasohol known to be good quality. Gasohol may contain up to 10% Ethanol (grain alcohol) or 15% MTBE (methyl tertiary-butyl ether). Gasohol containing methanol (wood alcohol) is NOT approved.

Two-Stroke Oil - A two-stroke engine oil meeting proposed ISO-L-EGD Standard (ISO/CD 13738), must be used. LW brand Premium 50:1 oil meets this proposed standard. Engine problems due to inadequate lubrication caused by failure to use an ISO-L-EGD approved oil, such as LW Premium 50:1 Two-stroke Oil, will void the two-stroke engine warranty. (Emission related parts only are covered for two years, regardless of two-stroke oil used, per the statement listed in the EPA Phase I/California Emission Defect Warranty Explanation.)

B. MIXING FUEL

1. Pour 1/2 of the gasoline into a safe container. **DO NOT** mix fuel in the engine fuel tank.
2. Add the oil to the gasoline and mix.
3. Add the remaining gasoline and remix.
4. Install fuel cap and wipe spilled fuel from container and area.

5. **Important**, two stroke fuel separates and ages. Do not mix more than you will use in a month. Shake fuel container to thoroughly mix fuel before each use. Do not attempt to run your engine on gasoline only, use the proper fuel mixture.

C. STARTING A COLD ENGINE

The trimmer has a Start/Stop ignition switch which must be used for starting and stopping the engine.

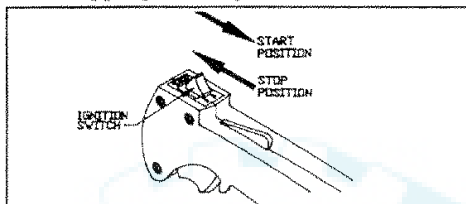

FOR SINGLE SIDED TRIMMERS

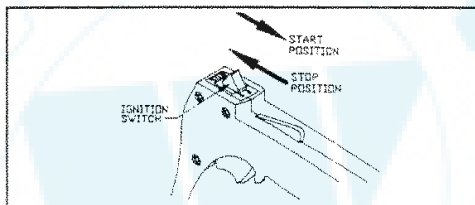

FOR DOUBLE SIDED TRIMMERS

1. Place the hedge trimmer flat on the ground, or another stable surface. Slide the ignition switch to the START position.
2. Pull choke knob out to COLD START (closed) position.
3. Push primer bulb 3 to 4 times, or until fuel is visible in the clear fuel return line.
4. Pull starter rope until engine sputters. Use short pulls, 1/2 to 2/3 of the rope length.

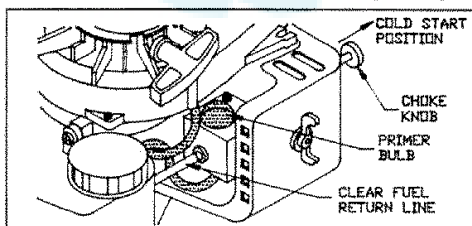

▲ WARNING DANGER ▲
AVOID ACCIDENTAL BLADE ENGAGEMENT.

DO NOT SQUEEZE THE THROTTLE TRIGGER WHEN STARTING.

MAINTAIN PROPER IDLE SPEED ADJUSTMENT (2200-2300 RPM)

5. Push choke knob in to RUN position.
6. Restart engine and allow it to warm up for a minute or two.
7. With both hands on the handles, squeeze throttle trigger gradually, to increase the engine speed and engage the blades.

NOTE: Allow engine to warm up 2-3 minutes before use. Failure to do so will cause engine damage.

D. STARTING A WARM ENGINE

1. Slide ignition switch to START position.
2. Push choke knob in to RUN (open) position.
3. If there is no fuel in the clear return line, push primer bulb 3-4 times or until fuel is visible in the line.
4. Pull starter rope using short pulls, 1/2 to 2/3 of the rope length.
5. If engine fails to start in 4 pulls, use cold start procedure.
6. With both hands on the handles, squeeze throttle trigger gradually to increase the engine speed and engage the blades.

E. STARTING A FLOODED ENGINE

1. Remove the cap from the spark plug and un-screw the plug with a spark plug wrench. If the end of the spark plug is wet, the engine may be flooded.

2. Disconnect spark plug wire and remove plug.
3. Use a paper towel or clean rag to dry the end of the spark plug.
4. Pull the choke knob out (closed position) and pull the starter rope several times.
5. Replace the spark plug and cap.
6. Push the choke knob in (open position) and pull starter rope three to four times.
7. Now pull the choke knob out (closed position) and pull the starter rope until the engine sputters.
8. Finally, push the choke knob in (open position) and pull the starter rope to start the engine

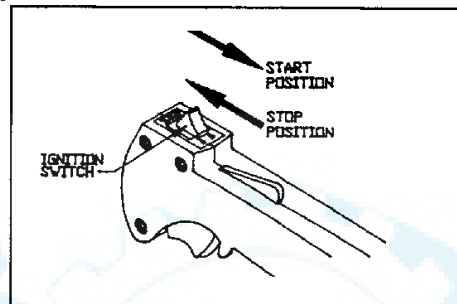
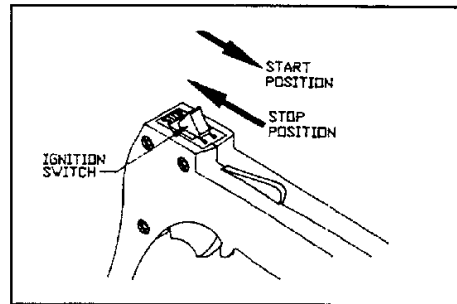

E. STOPPING THE ENGINE

1. Release the throttle trigger and allow engine to idle.
2. Slide ignition switch to the STOP position.
3. Make sure blades have come to a complete stop before releasing either handle.

⚠ WARNING DANGER ⚠

**IF ENGINE DOES NOT STOP WHEN SWITCH IS PUT IN THE STOP POSITION,
RELEASE THE THROTTLE TRIGGER, ALLOW ENGINE TO IDLE.**

**PUT THE TRIMMER DOWN, AND PULL THE CHOKE KNOB OUT TO
COLD START, (CLOSED) POSITION.**

**CHECK AND REPLACE IGNITION SWITCH BEFORE
STARTING ENGINE AGAIN.**

G. TRIMMING

▲ WARNING DANGER ▲
BLADES COAST AFTER RELEASING
THROTTLE OR STOPPING ENGINE.

KEEP A FIRM GRIP WITH BOTH
HANDS ON BOTH HANDLES WHILE
BLADES ARE MOVING AND/OR
ENGINE IS RUNNING.

DO NOT STAND ON THE TOP OF
A LADDER WHILE TRIMMING.

MAKE SURE YOUR LADDER OR
OTHER SUPPORT IS STABLE
AND ON FIRM GROUND.

KEEP A SURE FOOTING.
DO NOT OVERREACH.

IF YOUR TRIMMER BECOMES
JAMMED RELEASE THROTTLE
AND STOP ENGINE. MAKE SURE
BLADES HAVE STOPPED
COMPLETELY, THEN REMOVE
THE OBSTRUCTION.

1. **WARNING!** Read and follow all safety instructions in the manual before attempting to use this trimmer.
2. Only after you are familiar with your hedge trimmer and all of its controls and the functions should you start the engine.
3. Once the engine is started grasp the handles securely, the left hand should grasp the rear handle and the right hand should grasp the front side handle on Single Sided trimmers. On Double Sided trimmers, one hand grasps the front handle, while the other hand grasps the rear handle.
4. Squeeze the throttle to accelerate the engine and engage the blades.

5. Tilt the trimmer so the cutting teeth are angled slightly toward the hedge or shrub and proceed to cut. Use overlapping sweeping motions away from your body to achieve a safe and even cut.

6. This unit is designed to cut any type of hedge or shrub; however,

THICKNESS OF CUT
SHOULD NOT EXCEED
1 INCH IN DIAMETER.

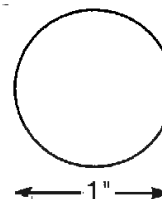

*Misuse of this Hedge
Trimmer will void the
warranty.*

ie: Cutting hedges or shrubs over 1" in diameter or foreign objects such as wires, rocks, or fences. Before trimming check work area for foreign objects such as wires, cords, glass, fences, or rocks. Be sure to remove any foreign objects from the work area. Failure to properly maintain this hedge trimmer will void the warranty.

V. MAINTENANCE

A. LUBRICATION

1. A few drops of a light #10 oil should be placed on the back edge of each blade guard at each adjusting screw approximately after every 4 hours of normal operation.
2. To obtain trouble free trimming, it is necessary to keep the blades lubricated and clean. The gum that collects and builds up on the blades can be removed with a 50-50 mixture of kerosene and #10 oil. As petroleum products can shorten the life of some plastics it is necessary to remove excess oil-kerosene mixture from the plastic parts.

3. When blades are replaced, or any other time that the bottom cover plate is removed, the grease level should be checked for proper amount (approximately 3/4 full in the area of the gears) and a new gasket should be used to insure proper seating of the cover plate. Use only Lubrico M3-3K-9K (P/N 16-78A) grease in the gear housing.

B. ENGINE

1. Air Filter

a. Clean the air filter before each use. Remove wing nut and air filter cover.

b. If filter is excessively dirty or no longer fits properly, replace it. Otherwise carefully brush dirt from filter or clean if necessary. Allow to air dry.

c. Re-install filter to inside cover making sure it is seated properly.

d. Re-install cover onto air cleaner case and secure with wing nut.

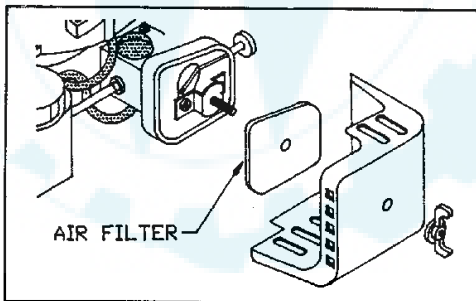

2. Cooling Fins

Remove dirt and debris from around cooling fins and exhaust before each use. Proper air circulation is essential for engine performance and life.

C. LONG TERM STORAGE (OVER 60 DAYS)

1. Store your trimmer in a dry and dust free space, out of the reach of children.

▲ WARNING DANGER ▲
DO NOT STORE IN AN AREA WHERE FUEL FUMES MAY ACCUMULATE AND REACH A FLAME OR SPARK.

2. Place the ignition switch in the stop position.

3. Clean the engine and blades thoroughly and coat the blades with #10 oil to prevent rust.

4. Perform all required maintenance and service found in this manual.

5. Drain the fuel tank and pull the starter rope several times to remove the fuel from the carburetor.

6. Remove the spark plug and pour 1/4 oz. of fresh, clean, two-stroke engine oil into the cylinder via the spark plug hole. Cover the hole with a rag and pull the starter rope 2-3 times.

7. While looking through the spark plug hole pull the starter rope until the piston reaches the top of it's stroke and stop.

8. Install the spark plug, but leave the ignition cable disconnected.

<u>VI. SERVICE</u>		
A. TROUBLE SHOOTING		
Problem	Cause	Remedy
1. Blades don't cut cleanly.	Blades are dull or not adjusted properly.	Have blades sharpened and adjusted.
2. Blades don't move when throttle is depressed.	Engine is not seated properly on the gear housing. Blades are adjusted too tight.	Re-install engine following the assembly instructions. Re-adjust blades following service instructions.
3. Engine fails to start	ON/OFF switch is in OFF position. No fuel in tank. Fuel strainer clogged. Fuel line clogged. Spark plug shorted or fouled. Spark plug is broken (cracked porcelain or electrodes broken). Ignition lead wire shorted, broken or disconnected from spark plug. Ignition inoperative (no spark from lead wire).	Move switch to ON. Fill Tank. Replace Strainer. Clean fuel line. Install new sparkplug Replace sparkplug. Replace lead wire or attach to sparkplug. Contact your nearest authorized dealer.
4. Engine hard to start	Water in gasoline or stale fuel mixture. Too much oil in fuel mixture. Engine under or over choked. Carburetor out of adjustment. Gasket leaks (carburetor or cylinder base gasket). Weak spark at sparkplug.	Drain entire system and refill with fresh fuel. Drain and refill with correct mixture. If flooded by over choking, proceed according to instructions in operation section. If under choked, move choke lever to closed position and crank two or three times. See "Carburetor Adjustment" Replace gaskets. Contact your nearest authorized dealer.
5. Engine misses.	Dirt in fuel line or carburetor. Carburetor improperly adjusted. Sparkplug fouled, broken or incorrect gap setting. Weak or intermittent spark at spark plug.	Remove and clean. See "Carburetor Adjustment" Clean or replace spark plug - set gap to 0.6-0.7 mm (.024-.028in.). Contact your nearest authorized dealer.

TROUBLE SHOOTING (CONT.)

Problem	Cause	Remedy
6. Engine lacks power.	Air cleaner clogged. Carburetor out of adjustment Muffler clogged. Clogged exhaust ports. Clogged spark arrestor Poor compression.	Clean air cleaner. See "Carburetor Adjustment". Clean carbon from muffler. Remove muffler, rotate engine until the piston is at top of cylinder. With a wooden scraper or blunt tool, remove all carbon from exhaust ports. Be careful not to scratch or damage piston or cylinder walls. Blow out all loose carbon with compressed air. Install muffler and gasket. Clean Contact your nearest authorized dealer.
7. Engine overheats.	Insufficient oil in fuel mixture. Air flow obstructed.	Mix fuel as described in starting instructions. Clean flywheel, cylinder fins and screen.
8. Engine noisy or knocking.	Loose flywheel. Spark plugs incorrect heat range. Worn bearings, piston ring or cylinder walls.	Tighten flywheel nut. Replace with plugs specified for engine. Contact your nearest authorized dealer.
9. Engine stalls under load..	Carburetor adjustment: too "lean". Engine overheats.	See "Carburetor Adjustment". Remove dust and dirt from between cylinder fins.

B. ENGINE SPECIFICATIONS

Dry Weight	2.5 kg — 5 lbs., 10 ounces
Type of Engine	Air Cooled, Two stroke, Single-Cylinder, Gasoline Engine
Rotation	Counterclockwise, viewed from TOP
Bore	32.2 mm (1.268 in.)
Stroke	26.0 mm (1.04 in.)
Spark Plug	NGK BPM6A, CHAMPION CJ-8Y, AUTOLITE 2976 The spark plug gap is 0.65 mm (0.026"). Refer to Operator's Manual, for service Procedure
Fuel	Premixed two stroke fuel
Fuel Oil Ratio	50:1 ratio with ECHO oil
Gasoline	Unleaded, 89 octane or higher
Displacement	21.2 cc (1.294 cu. in.)
Exhaust System	Spark arrester muffler
Carburetor	ZAMA diaphragm model CIU type. RPM at idle 2800 : 250 RPM
Ignition System	There are no adjustments required for the ignition

B. ENGINE SPECIFICATIONS (CONTINUED)

Clutch Centrifugal type
 Ignition System Flywheel magneto, capacitor discharge ignition type

C. SERVICE MAINTENANCE GUIDE

Area	Maintenance	Frequency
Air Filter	Clean Replace	Daily or every 4 hrs. use Every 3 mths. or 100 hrs. use
Fuel Filter	Inspect / Replace	Monthly
Spark Plug	Clean Replace	Every 3 mths. or 100 hrs. use 6 months or 300 hrs. use
Carburetor	Check / Rebuild Replace	6 months or 300 hrs. use Yearly or 600 Hrs. use ①
Cooling System	Inspect / Clean	Before Use
Muffler (Spark Arrestor)	Inspect / Clean	Monthly
Gear Housing	Check Grease	Monthly
Blades	Inspect / Clean / Lubricate	After Use
Fuel Leaks	Inspect / Repair	Before Use
Fasteners	Inspect / Tighten / Replace	Before Use
Labels	Inspect / Replace	Before Use
Handles	Inspect / Replace	Before Use
Guards / Safety Devices	Inspect / Replace	Before Use
Fuel Line	inspect / Replace	Monthly
Starter Rope	Inspect / Replace	Monthly
Fuel Strainer	Replace	Every 3 mths. or 100 hrs. use
Choke	Check	With each re-fueling
Ignition System	Clean Replace	No maintenance For coil and flywheel

① Replacement will be required for commercial use after 600 hours. For Consumer use, cleaning every 6 months is required. Cleaning includes Rebuild Kits.

IMPORTANT- Time Intervals shown are maximum. Actual use and your experience will determine the frequency of required maintenance.

D. BLADE ADJUSTMENT

The care and adjustment of the blades is very important to the efficient operation of the trimmer and especially to the long life of the engine.

1. Place trimmer in vise, clamping on the frame bar. **Be careful! Blades are sharp!**
2. Using a 7/16" wrench, loosen all blade locknuts and unscrew the large head screws by two turns.
3. Starting with the screw nearest the gear housing, tighten the screw until the blade guard of the Single Sided trimmer or the protective comb of the Double Sided trimmer can just be moved with

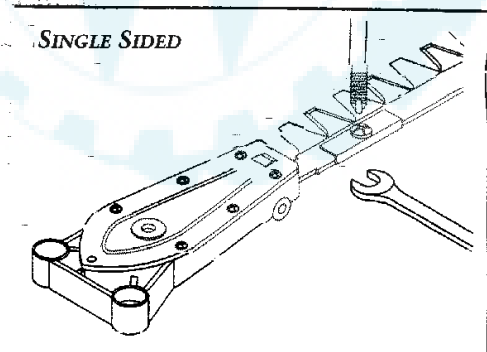

finger pressure and a .0015" (1 1/2 thou.) feeler blade just slips under the blade

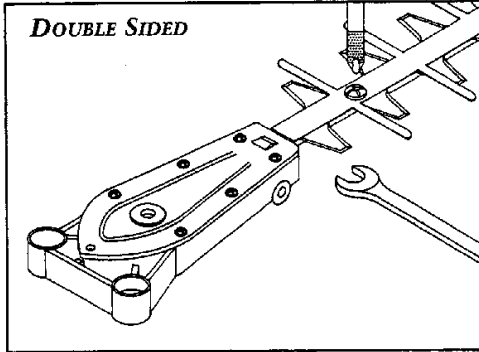

guard or comb. Tighten the locknuts while holding the screw stationary in its correct adjusted position.

4. Repeat Step 3 on the screws in turn until all are correctly adjusted.

NOTE: CORRECT BLADE ADJUSTMENT CAN ONLY BE ACHIEVED ON CLEAN, OILED BLADES.

E. CARBURETOR ADJUSTMENT (AS NEEDED)

1. General

NOTE: The diaphragm carburetor has three external adjustments. Each adjustment affects the others.

The idle speed adjustment screw controls the throttle opening at idle position.

The low (LO) speed adjustment screw controls the volume of fuel mixture at low engine speed. It also controls the supplementary fuel required to obtain smooth progression from idling to high speed.

The high (HI) speed adjustment screw controls the volume of fuel mixture at full throttle.

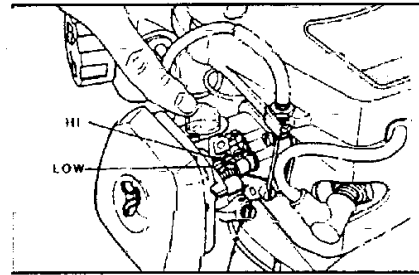

2. Carburetor Adjustment

Every unit is run at the factory and the carburetor is set in compliance with EPA Phase I / California Emission Regulations. In addition, the carburetor is equipped with HI and LO needle adjustment limiters that prevent settings outside acceptable limits.

NOTE: The needle screws have a sharp point. To avoid damage to the carburetor, do not use excessive force.

1. Before adjusting carburetor clean or replace air filter and muffler, "Spark Arrestor Screen".
2. Make sure the cutting attachment such as hedge clipper blades are properly adjusted.
3. Start engine and run several minutes to bring to operating temperature. Flash choke twice during warm-up to clear any air from the fuel system.

▲ WARNING DANGER ▲

KEEP HANDS AWAY FROM THE BLADES WHILE SERVICING THE HEDGE TRIMMER. BE SURE TRIMMER IS SECURED AND BLADES ARE GUARDED WHILE MAKING ADJUSTMENTS

NOTE: The Idle speed screws may have to be re-adjusted to keep engine from stalling. The Engine must be at normal operating temperature to adjust properly.

VII PARTS EXPLOSIONS

Key No.	Part No.	Description	Qty.
1	371	Pinion	1
2	375	Washer	1
3	374	Upper Bushing	1
4	300000	Gear Hsg Assem. (inc. Key No. 3, 6, 12)	1
5	D16-56F	Wear Plate	1
6	16-61	Eccentric Shaft	1
7	372	Eccentric Gear	1
8	314	Felt	1
9	319	Gasket	1
10	316	Cover Plate	1
11	16-81	6-32 x 5/16 Screw Pack	1
12	16-80	Cover Plate Pin	1
13	373	Lower Bushing	1

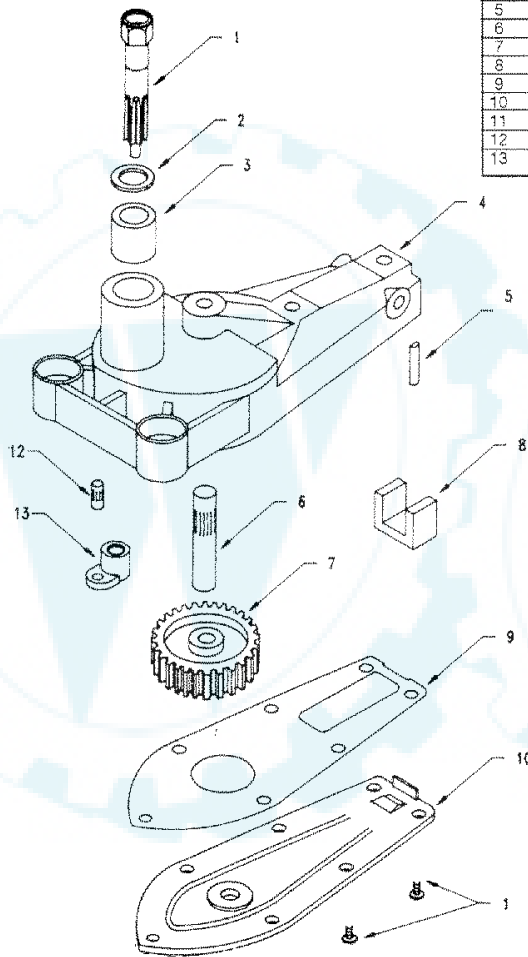

GEAR HOUSING ASSEMBLY

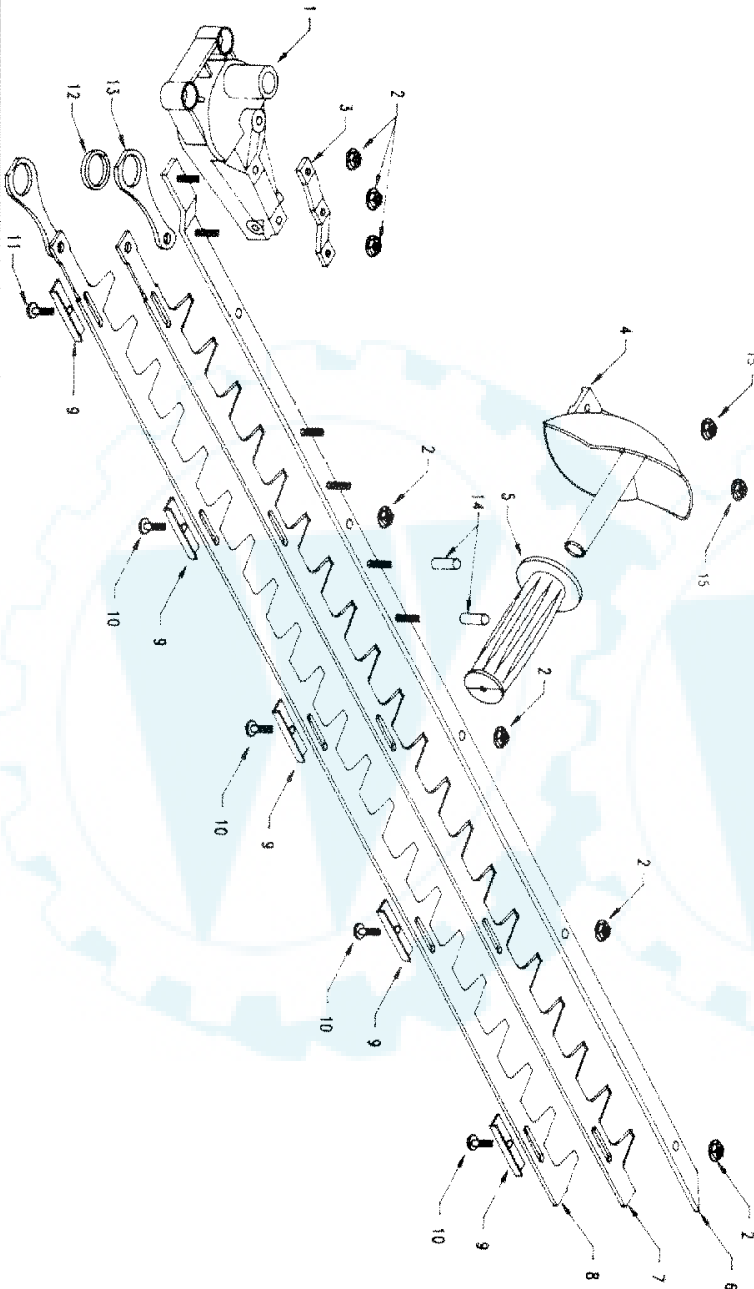

Key No.	Part No.	Description	Qty.
1	300300	Gear Housing Assembly	1
2	16-54B	1/4-28 WHlz Flange Locknut (For Model 2230S)	7
3	300300	1/4-28 WHlz Flange Locknut (For Model 2242S)	9
4	300200	Frame Bar Brace	1
5	300201	Side Handle	1
6	300310	Grip	1
7	300314	30° Frame Bar (For Model 2230S)	1
8	30-2	42° Frame Bar (For Model 2242S, Not Shown)	1
9	42-2	30° Inside Blade (For Model 2230S)	1
10	30-1	42° Inside Blade (For Model 2242S, Not Shown)	1
11	42-1	30° Outside Blade (For Model 2230S)	1
12	42-1	42° Outside Blade (For Model 2242S, Not Shown)	1

Key No.	Part No.	Description	Qty.
9	16-93	Blade Guard (For Model 2230S)	5
9	16-93	Blade Guard (For Model 2242S)	7
10	16-54A	Large Head Phillips Screw (For Model 2230S)	4
10	16-54A	Large Head Phillips Screw (For Model 2242S)	6
11	300504	Large Head Screw 1/4-28 x 7/8	1
12	16-65	Connecting Rod Spacer	1
13	16-64	Connecting Rod	1
14	300316	Thread Protector (For Model 2230S)	2
15	3036-B	1/4-28 Flange Locknut	2

SINGLE SIDED TRIMMER
CUTTING BAR AND SIDE HANDLE ASSEMBLY

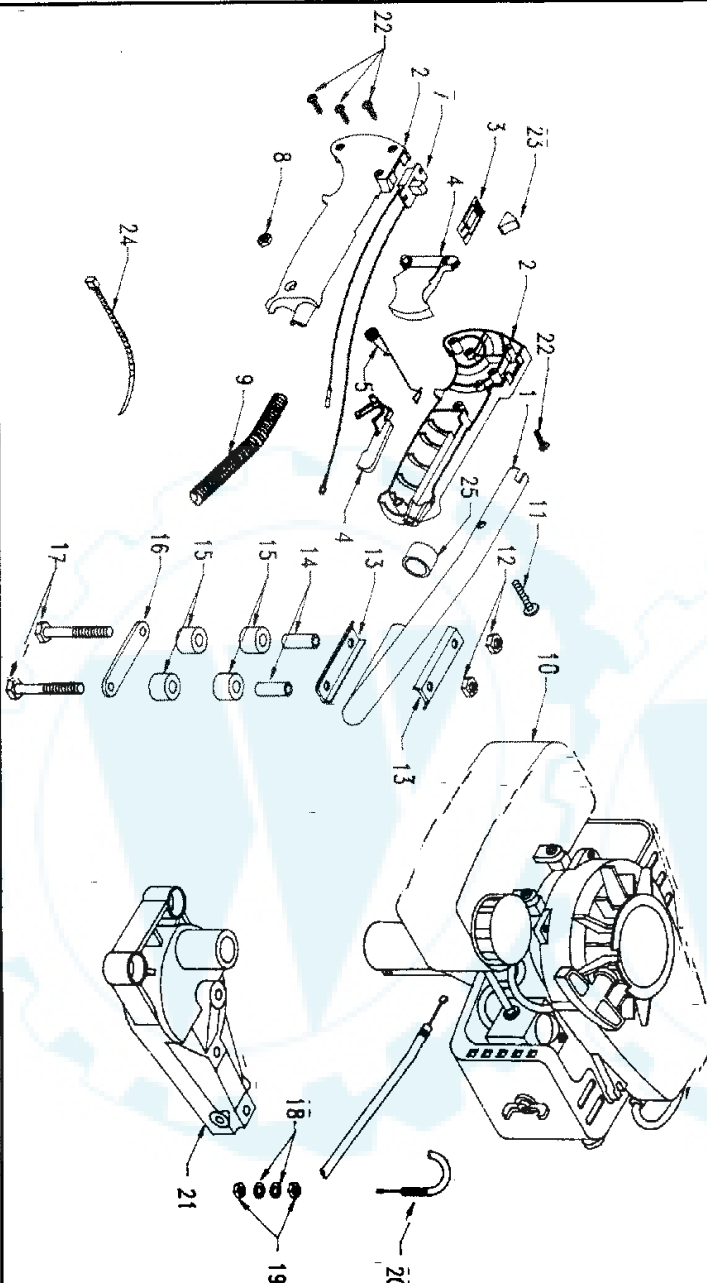

Key No.	Part No.	Description	Qty.
1	300101	Handle	1
2	300103	Grip Seal	1
3	300117	Switch Plate	1
4	300122	Trigger Set	1
5	300108	Trigger Lockout Springs	1
7	300110	Switch/Wash Leads	1
8	973	10-32 Lock Nut	1
9	300116	Conduit	1
10	390F-41HF	Engine	1
11	300503	10-32 x 1 1/4" Machine Screw	1
12	972	1/4-20 Lock Nut	1
13	300102	Handle Support Channel	2

Key No.	Part No.	Description	Qty.
14	300113	Spacer	2
15	300111	Shock Absorber	4
16	300112	Support Plate	1
17	300505	1/4-20 x 2 1/2" Bolt	2
18	300502	6MM Star Lock Washer	2
19	300500	6MM Nut	2
20	300115	Throttle Cable	1
21	300000	Gear Housing Assembly	1
22	300511	7/8" Phillips Pan Head Screw	4
23	300109	Switch Cap	1
24	300118	Cable Tie	1
25	376-1	Handle End Cap	1

SINGLE SIDED TRIMMER ENGINE AND REAR HANDLE ASSEMBLY

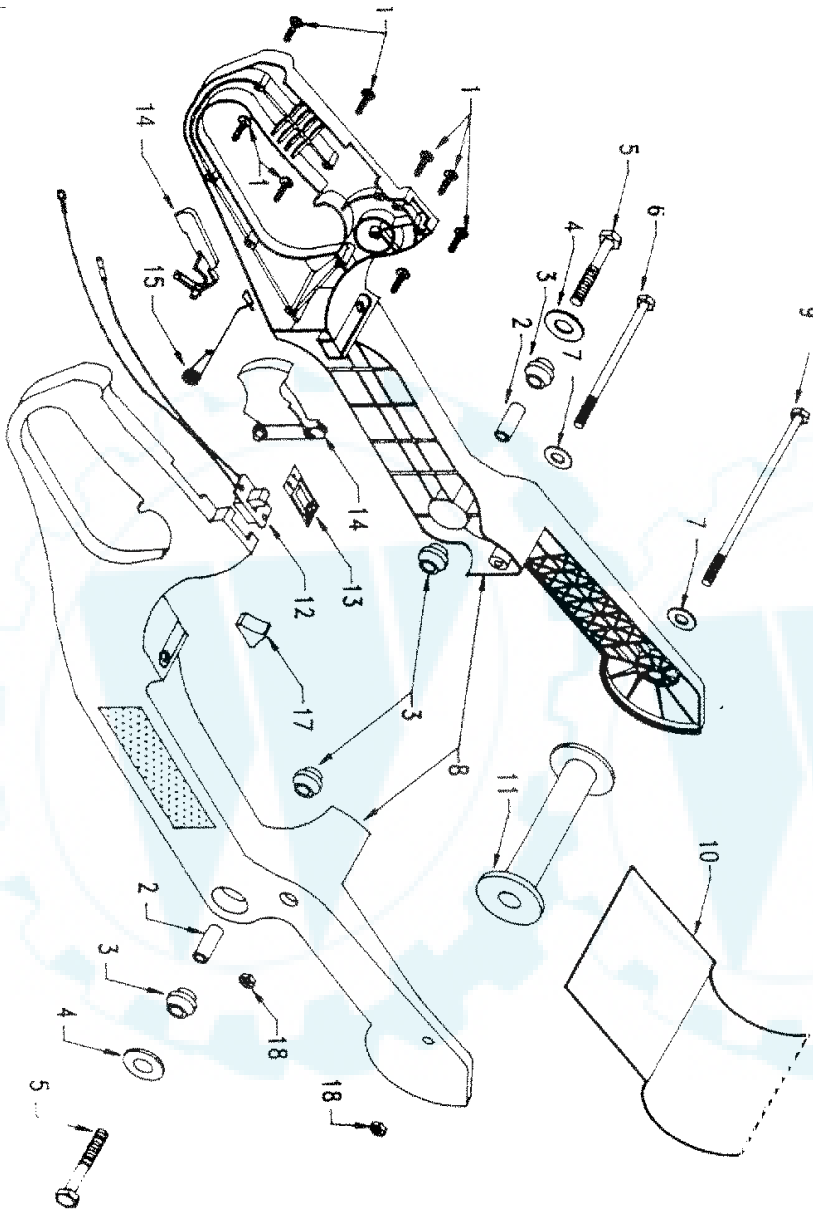

Key No.	Part No.	Description	Qty.
1	300511	7/8" Phillips Pan Head Screw	8
2	300113	Spacer	4
3	300403	Shock Absorber	8
4	328	1/4" Flat Washer	2
5	300506	1/4-28 x 1 5/8 Hex Head Bolt	2
6	300510	10-32 x 4 Hex Head Bolt	1
7	300508	#10 Flat Washer	2
8	300400	Grip Set	1
9	300507	10-32 x 5 1/2 Hex Head Bolt	1

Key No.	Part No.	Description	Qty.
10	300405	Hand Guard	1
11	300404	Front Handle	1
12	300110	Switch With Leads	1
13	300117	Switch Plate	1
14	300122	Trigger Set	1
15	300108	Trigger/Lockout Spring	1
16	300109	Switch Cap	1
17	973	10-32 Locknut	1
18			2

**DOUBLE SIDED TRIMMER
HANDLE ASSEMBLY**

Key No.	Part No.	Description	Qty.
1	380E-4BH/E	Engine	1
2	300715	Throttle Cable	1
3	300500	6MM Nut	2
4	300502	6MM External Star Lockwasher	1
5	300119	Conduit	1
6	16-448	1/4" - 28 Whitiz Flange Locknut - Model 2230D Model 2224D	6
7	300312	30" D.S. Frame Bar w/Studs - Model 2216D	5
7	300308	24" D.S. Frame Bar w/Studs - Model 2230D	1
7	300304	16" D.S. Frame Bar w/Studs - Model 2224D	1
8	30-2D	30" D.S. Inside Blade - Model 2230D	1
8	24-2D	24" D.S. Inside Blade - Model 2224D	1
8	16-52D	16" D.S. Inside Blade - Model 2216D	1
8	30-1D	30" D.S. Outside Blade - Model 2230D	1
8	24-1D	24" D.S. Outside Blade - Model 2224D	1
8	16-51D	16" D.S. Outside Blade - Model 2216D	1

Key No.	Part No.	Description	Qty.
10	30-42	30" Protective Comb - Model 2230D	1
10	24-42	24" Protective Comb - Model 2224D	1
10	16-42	16" Protective Comb - Model 2216D	1
11	16-544	Large Head Phillips Screw - Model 2230D Model 2224D	4
12	300504	7/8" Large Head Phillips Screw Model 2216D	2
13	16-65	Connecting Rod Spacer	1
14	16-64	Connecting Rod	1
15	300512	1/4" - 20 x 2 1/4 Bolt	2
16	300712	Support Plate	3
17	300403	Shock Absorber	8
18	300000	Gear Housing Assembly	8
19	300113	Spacer	4
20	972	1/4" - 20 Locknut	4
21	300300	Frame Bar Brace	1

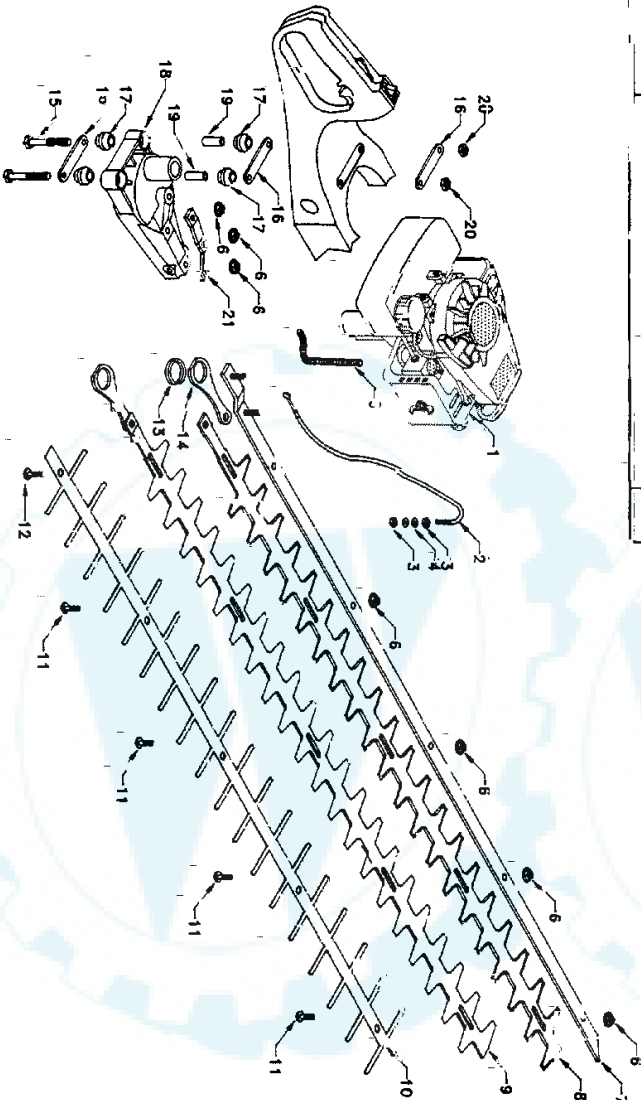

**DOUBLE SIDED TRIMMER
CUTTING BAR, HANDLE AND ENGINE ASSEMBLY**

SV-4B (H) TYPE 1E

CARBURETOR

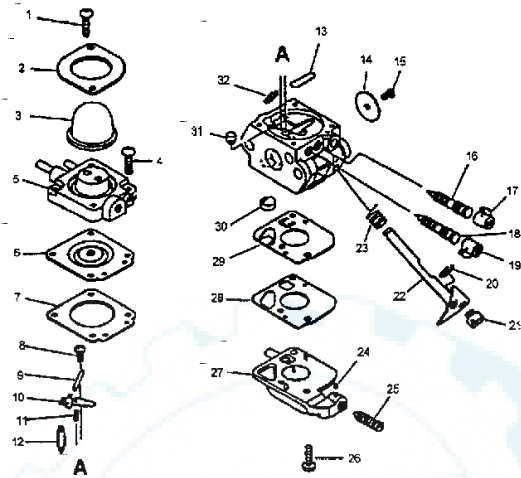

KEY	PART No.	QTY	DESCRIPTION
	12520013120	1	CARBURETOR ASY
1	12534405360	2	SCREW
2	12536308560	1	RING
3	12538108660	1	PUMP, PURGE
4	12531005360	2	SCREW
5	12533305360	1	BASE, PURGE
6	A B	1	DIAPHRAGM, METERING
7	A B	1	GASKET, METERING
8	12533942030	1	SCREW
9	A	1	PIN, METERING ARM
10	A	1	LEVER, METERING
11	A	1	SPRING, METERING LEVER
12	A	1	VALVE, INLET NEEDLE
13	A	1	PLUG, WELCH
14	12531649030	1	VALVE, THROTTLE
15	12531413930	1	SCREW
16	12531813120	1	NEEDLE, LOW SPEED
17	12532908660	1	CAP, LIMITER L.S.
18	12532013310	1	NEEDLE, HIGH SPEED
19	1253293030	1	CAP, LIMITER H.S.
20	12532713930	1	CLIP
21	12537242030	1	SWIVEL
22	12531713310	1	SHAFT, THROTTLE
23	12531342030	1	SPRING, THROTTLE RETURN
24	12537813930	1	PIECE, FRICTION
25	12533413930	1	SCREW, IDLE ADJUST
26	12531012820	2	SCREW
27	12530612820	1	COVER, PUMP
28	A B	1	GASKET, FUEL PUMP
29	A B	1	DIAPHRAGM, FUEL PUMP
30	A	1	STRAINER
31	12537649030	1	NOZZLE, MAIN CHECK VALVE
32	12532715130	1	CLIP

SV-4B (H) TYPE 1E

INTAKE, AIR FILTER

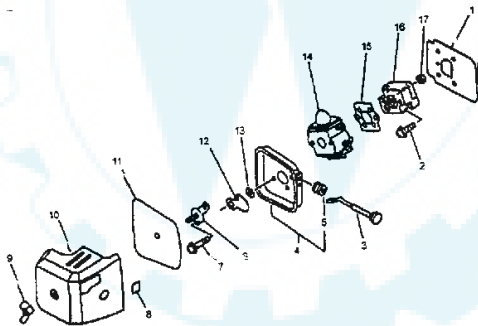

KEY	PART No.	QTY	DESCRIPTION	REMARKS
1	13001042032	1	GASKET, INTAKE	INCLUDED IN KIT 88900045131
2	90023805020	2	SCREW 5X20	
3	17851004560	1	ROD, CHOKE	
4	13030104560	1	CASE, AIR CLEANER	INCLUDES ITEM 5
5	17881005230	1	GROMMET	
6	13041005360	1	BRACKET, AIR CLEANER	
7	90024205057	2	SCREW 5X57	
8	89012140630	1	LABEL, CHOKE	
9	90052800005	1	NUT, WING	
10	13032611521	1	COVER, AIR CLEANER	
11	13031004560	1	FILTER, AIR	
12	17851504560	1	SHUTTER, CHOKE	
13	17851600830	1	SPACER	
14	12520013120	1	CARBURETOR ASY	
15	13001642031	1	GASKET, INTAKE	INCLUDED IN KIT 88900045131
16	13001742031	1	INSULATOR	
17	90050000005	2	NUT 5	

SV-4B (H) TYPE 1E

CYLINDER COVER, MUFFLER

KEY	PART No.	QTY	DESCRIPTION	REMARKS
20	14580011820	1	MUFFLER ASY	INCLUDES ITEMS 21 - 26
21	14551042031	2	GASKET, MUFFLER	INCLUDED IN KIT 88900045131
22	14586240630	1	SCREEN, MUFFLER	
23	14586642031	1	GASKET, MUFFLER LID	INCLUDED IN KIT 88900045131
24	14587642030	1	LID, MUFFLER	
25	14586306960	1	FIXTURE, SCREEN	
26	90024204010	3	SCREW 4X10	
27	90010505050	2	BOLT 5X50	
28	90060000005	2	WASHER 5	
29	14587105360	1	COVER, MUFFLER	

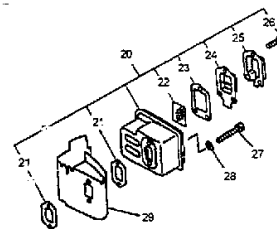

**SV-4 (H) ENGINE
FUEL TANK LAYOUT**

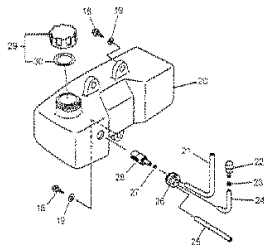

KEY	PART No.	QTY	DESCRIPTION	REMARKS
20	13100511820	1	TANK, FUEL	
21	13201011520	1	PIPE 3X5X210	
22	13139040630	1	VALVE, CHECK	
23	13011100530	1	CLIP, PIPE	
24	13131244330	1	PIPE 3X5X70	
25	13201049030	1	PIPE 3X6X50	
26	13211546730	1	GRGMMET. RUEL	
27	13201306820	1	CLIP	
28	13120507320	1	STRAINER, FUEL	
29	13100453530	1	CAP ASY, FUEL TANK	INCLUDES ITEM 30
30	13101656830	1	GASKET, FUEL TANK CAP	

SV-4B (H) TYPE 1E

CYLINDER COVER, MUFFLER

KEY	PART No.	QTY	DESCRIPTION	REMARKS
1	10020411520	1	CRANKCASE KIT	INCLUDES ITEMS 2 - 6
2	10021249330	2	SEAL, OIL	
3	10021605930	2	PIN, DOWEL	
4	-----	1	GASKET, CRANKCASE	INCLUDED IN KIT 88900045131
5	90081036201	2	BEARING, BALL 6201	
6	90016205028	3	BOLT 5X28	
7	10010013120	1	CRANKSHAFT ASY	
8	61032502730	1	KEY, WOODRUFF	
9	10060906960	1	PISTON, KIT	INCLUDES ITEMS 10 - 14
10	10001105330	2	RING, PISTON	
11	10001564630	2	CIRCLIP, PISTON PIN	
12	10001468960	2	SPACER, PISTON PIN	
13	10011305930	1	BEARING, NEEDLE	
14	10001311520	1	PIN, PISTON	
15	10101044232	1	GASKET, CYLINDER BASE	INCLUDED IN KIT 88900045131
16	10101106561	1	CYLINDER	
17	90016205022	2	BOLT 5X22	
18	90023904018	2	SCREW 4X18	
19	10150612820	1	COVER, CYLINDER	

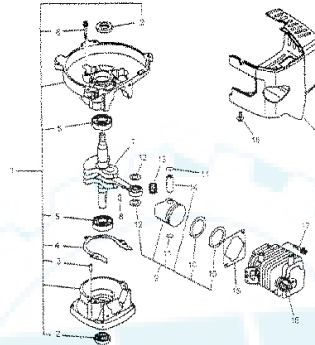

SV-4B (H) TYPE 1E

STARTER, IGNITION, CLUTCH

KEY	PART No.	QTY	DESCRIPTION	REMARKS
1	177200 12R20	1	STARTER ASY	INCLUDES ITEMS 2 - 7
2	17720042330	1	SPRING REWIND	
3	17721544430	1	DRUM, STARTER	
4	17723644330	1	SCREW	
5	-----	1	ROPE, STARTER	USE BULK ROPE 89944400040 3.0 X 880 (12 X 33.5)
6	17722742330	1	GUIDE, ROPE	
7	17722911120	1	GRIP, STARTER	
8	90023804315	4	SCREW 4X16	
9	90080500308	1	WASHER, SPRING 6	
10	90016204022	2	BOLT 4X22	
11	15662611520	1	CDL, IGNITION	
12	99944503071	1	SPARK PLUG 8PM-7V	
13	15301105430	1	CDL, SPARK PLUG	
14	15301201520	1	CASE, SPARK PLUG	
15	15611004920	1	BUSHING	
16	15680144330	1	FLYWHEEL	
17	17720212220	1	PAWL ASY, STARTER	INCLUDES ITEMS 18 & 19
18	17723442030	2	SPRING, PAWL RETURN	
19	17721844330	2	PAWL, STARTER	
20	90060000305	1	WASHER 5	
21	90080500305	1	WASHER, SPRING 5	
22	90011505925	1	BOLT 5X25	
23	90023804014	4	SCREW 4X14	
24	61022311520	1	CASE, CLUTCH	
25	17501064630	1	DRUM, CLUTCH	
26	90023805912	1	SCREW 5X17	
27	17501411520	1	WASHER, CLUTCH	
28	17504404830	1	WASHER, CLUTCH	
29	90080836900	1	BEARING, BALL 6000	
30	90060000310	1	WASHER 10	
31	17501804630	1	PLATE, CLUTCH	
32	17500007331	1	CLUTCH ASY	INCLUDES ITEMS 33 - 35
33	17500009131	2	SHOE, CLUTCH	
34	17501805130	2	SPRING, CLUTCH	
35	17501605020	1	HUB, CLUTCH	

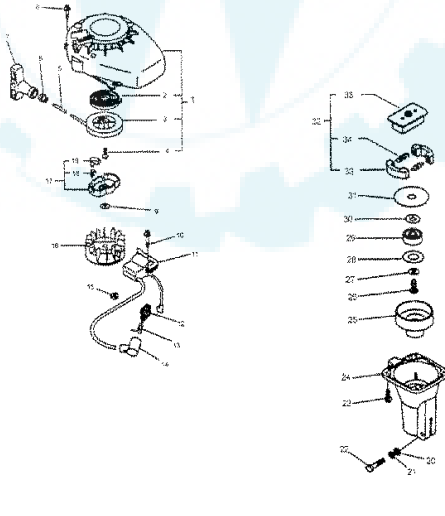

EMISSIONS DEFECT WARRANTY EXPLANATION

This is additional detailed information about the **EPA PHASE I and the CALIFORNIA EMISSIONS DEFECT WARRANTY** for your utility and/or lawn and garden equipment engine.

WHAT DOES THIS WARRANTY COVER?

The Manufacturer warrants that your unit was designed, built and equipped to conform with applicable EPA Phase I/California emissions standards and that your unit is free from defects in material and workmanship that would cause it to fail to conform with applicable requirements within two (2) years. *The warranty period begins on the date the product is delivered to a retail purchaser.* This is your emission control system, **DEFECTS WARRANTY**.

HOW WILL A COVERED PART BE CORRECTED?

If there is a defect in a part covered by this warranty, **The Manufacturer's** Authorized Service Dealer will correct the defect.

You will not have to pay anything to have the part adjusted, repaired or replaced. This includes any labor and diagnosis for warranted repairs performed by the dealer. *In addition, engine parts not expressly covered under this warranty but whose failure is a result of a failure of a covered part will be warranted.*

Emissions System repairs covered under this warranty should be completed in a reasonable time, not to exceed 30 days.

IMPORTANT

If the diagnosis reveals no defect, the emission defect warranty does not apply.

WHAT PARTS ARE COVERED BY THE EPA PHASE I/CALIFORNIA EMISSIONS DEFECT WARRANTY?

- Any emission related part not scheduled for, "required maintenance" (See Engine Operators Manual, "SERVICE MAINTENANCE SCHEDULE") will be repaired or replaced within the warranty period. The repaired or replaced part will be warranted for the remaining Emissions Defect warranty period.
- Any emission related part scheduled for replacement during "required maintenance" (See Engine Operators Manual, "SERVICE MAINTENANCE SCHEDULE") is warranted for the period of time prior to the first scheduled replacement point for that part. Any such part repaired or replaced under warranty shall be warranted for the remainder of the period prior to the first scheduled replacement point for that part.
- Any manufacturer-approved replacement part may be used in the performance of any warranty maintenance or repairs on emission-related parts, and must be provided without charge if the part is still under warranty.
- Any replacement part that is equivalent in performance and durability may be used in non-warranty maintenance or repairs, and shall not reduce the warranty obligations of the manufacturer.
- *The owner is responsible for the performance of the required maintenance described in the operators manual.*

SPECIFIC EMISSION RELATED WARRANTED PARTS:

Carburetor (complete assembly or replaceable components)
Air Filter
Electronic Ignition System
Spark Plug

WHAT IS NOT COVERED BY THE EMISSIONS DEFECT WARRANTY?

- *Any failure caused by abuse, neglect, improper maintenance.*
- *Any failure caused by unapproved modifications, use of unapproved add-on parts/modified parts or unapproved accessories.*

**EMISSION CONTROL
WARRANTY STATEMENT**

EPA Phase I; California Air Resources Board, and **your Equipment Manufacturer** are pleased to explain the emission control system warranty on your (year) utility or lawn and garden equipment engine. New utility and lawn and garden equipment engines must be designed, built and equipped to meet stringent EPA Phase I/California anti-smog standards. **Echo, Incorporated** must warrant the emission control system on your utility or lawn and garden equipment engine for the periods of time listed below provided there has been no abuse, neglect or improper maintenance of your utility or lawn and garden equipment engine.

Your emission control system may include parts such as the carburetor fuel system, and the ignition system. Also included may be hoses, belts, connectors and other emission-related assemblies.

Where a warrantable condition exists, **The Manufacturer** will repair your utility or lawn and garden equipment engine at no cost to you including diagnosis, parts and labor.

MANUFACTURER'S WARRANTY COVERAGE:

The 1996 and later utility and lawn and garden equipment engines are warranted for two years. If any emission-related part on your engine is defective, the part will be repaired or replaced by **The Manufacturer**.

OWNER'S WARRANTY RESPONSIBILITIES:

- As the utility or lawn and garden equipment engine owner, you are responsible for the performance of the required maintenance listed in your *Operators Manual*. **The Manufacturer** recommends that you retain all receipts covering maintenance on your utility or lawn and garden equipment engine, but **The Manufacturer** cannot deny warranty solely for the lack of receipts or for your failure to ensure the performance of all scheduled maintenance.
- As the utility or lawn and garden equipment engine owner, you should however be aware that **The Manufacturer** may deny you warranty coverage if your utility or lawn and garden equipment engine or a part has failed due to abuse, neglect, improper maintenance or unapproved modifications.
- You are responsible for presenting your utility or lawn and garden equipment engine to an **The Manufacturer** authorized service center as soon as a problem exists. The warranty repairs should be completed in a reasonable amount of time, not to exceed 30 days.

If you have any questions regarding your warranty rights and responsibilities, you should contact **your Product Manufacturer**.

03/97

TABLE OF CONTENTS

	Page
<i>I. IMPORTANT INFORMATION</i>	
A. Introduction	2
B. Service Information	3
C. Special Safety Information	3
<i>II. SAFETY AND WARNINGS</i>	
A. Safety Decals.....	4
B. Safety Decal Identification.....	4
C. General Safety Rules	5
D. Warnings — Dont's	5
E. Warnings — Do's.....	6
F. Engine/Fuel Warnings Dont's	7
G. Engine/Fuel Warnings Do's.....	7
<i>III. ASSEMBLY INSTRUCTIONS</i>	8
<i>IV. OPERATION</i>	
A. Fuel Mixture.....	8
B. Mixing Fuel.....	8
C. Starting a Cold Engine.....	8-9
D. Starting a Warm Engine.....	9
E. Starting a Flooded Engine.....	9
F. Stopping the Engine.....	9
G. Trimming.....	10
<i>V. MAINTENANCE</i>	
A. Lubrication	10-11
B. Engine.....	11
C. Long Term Storage(over 60 days).....	11
<i>VI. SERVICE</i>	
A. Trouble Shooting.....	12 - 13
B. Engine Specifications	13 - 14
C. Service Maintenance Guide.....	14
D. Blade Adjustment.....	14 - 15
E. Carburetor Adjustment.....	15 - 16
<i>VII. PARTS EXPLOSIONS</i>	16 - 20

I. IMPORTANT INFORMATION

A. INTRODUCTION

On behalf of everyone at **Little Wonder**, we would like to thank you for your purchase of a **Little Wonder** Gasoline Powered Hedge Trimmer. This professional trimming machine was designed to the highest standards to ensure you many hours of uninterrupted service.

This manual provides the information necessary for safe and efficient operation and service. For your safety, it is critically important that you read and understand this entire manual before operating your hedge trimmer.