

tielbürger

- Ⓚ **Kehrmaschine**
- ⓕ **Balayeus**
- ⓐ **Rotary Brush**
- Ⓡ **Spazzolatrice**
- Ⓝ **Feiemaskin**

tk 32

Ersatzteilliste
Pièces détachées
Spare list
Lista ricambi
Deleliste

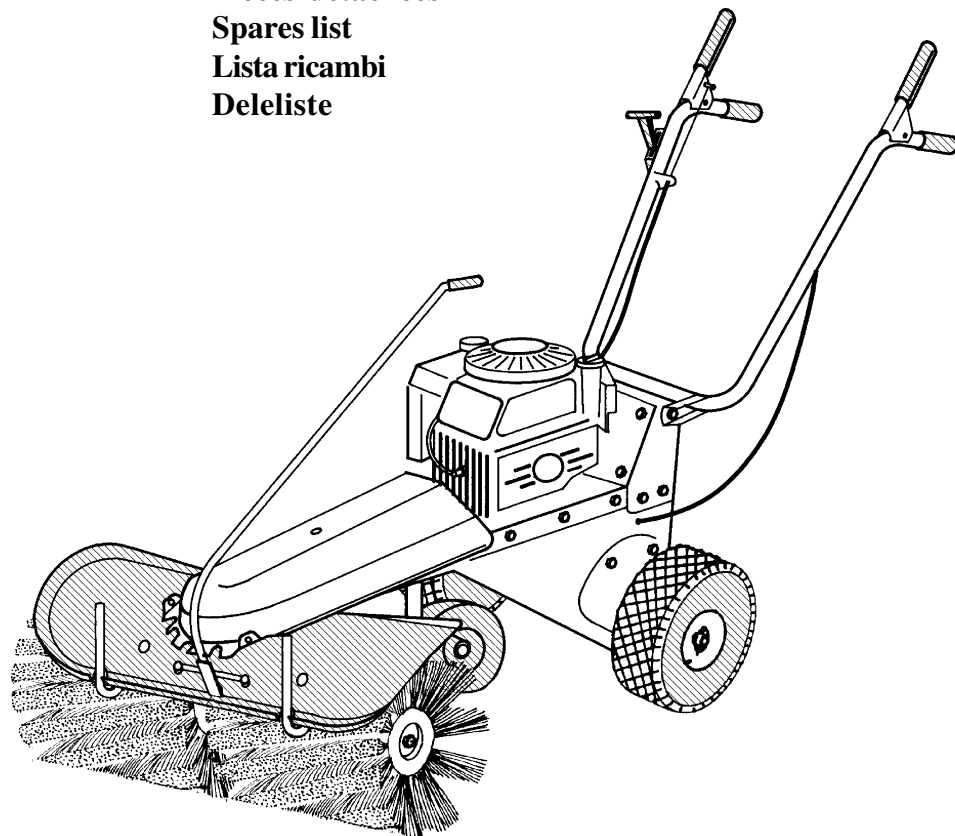

Inhalt

Sommaire
Contents
Contenuto
Innhold

Seite
Page
Page
Pagina
Side





Lenker _____ Mancheron Handle bars Manubrio Styre	4 - 5
Gehäuse mit Konsole _____ Arbre avec embase Housing with bracket Scatola con mensola Hus med feste	6 - 7
Stützrad _____ Roue-support Supporting wheel Ruota supporto Hjul	8 - 11
Winkelgetriebe _____ Renvoi d'angle Bevel drive Rinvio Vinkelgear	12 - 13
Getriebe _____ Boîte de vitesses Gear drive Trasmissione Gear	14 - 15
Räder und Farbsprühdosen _____ Roues et bombes de peintures Wheels and spray paint tins Ruote e vernice spray da ritocco	16 - 17
Zubehör _____ Accessoires Appurtenances Gli accessori Ekstrautstyr	18 - 19

Briggs & Stratton 3,5HP
Max.: 2,6 kW / 3600 rpm
Eff.: 2,2 kW / 3000 rpm

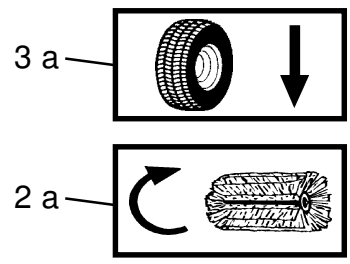
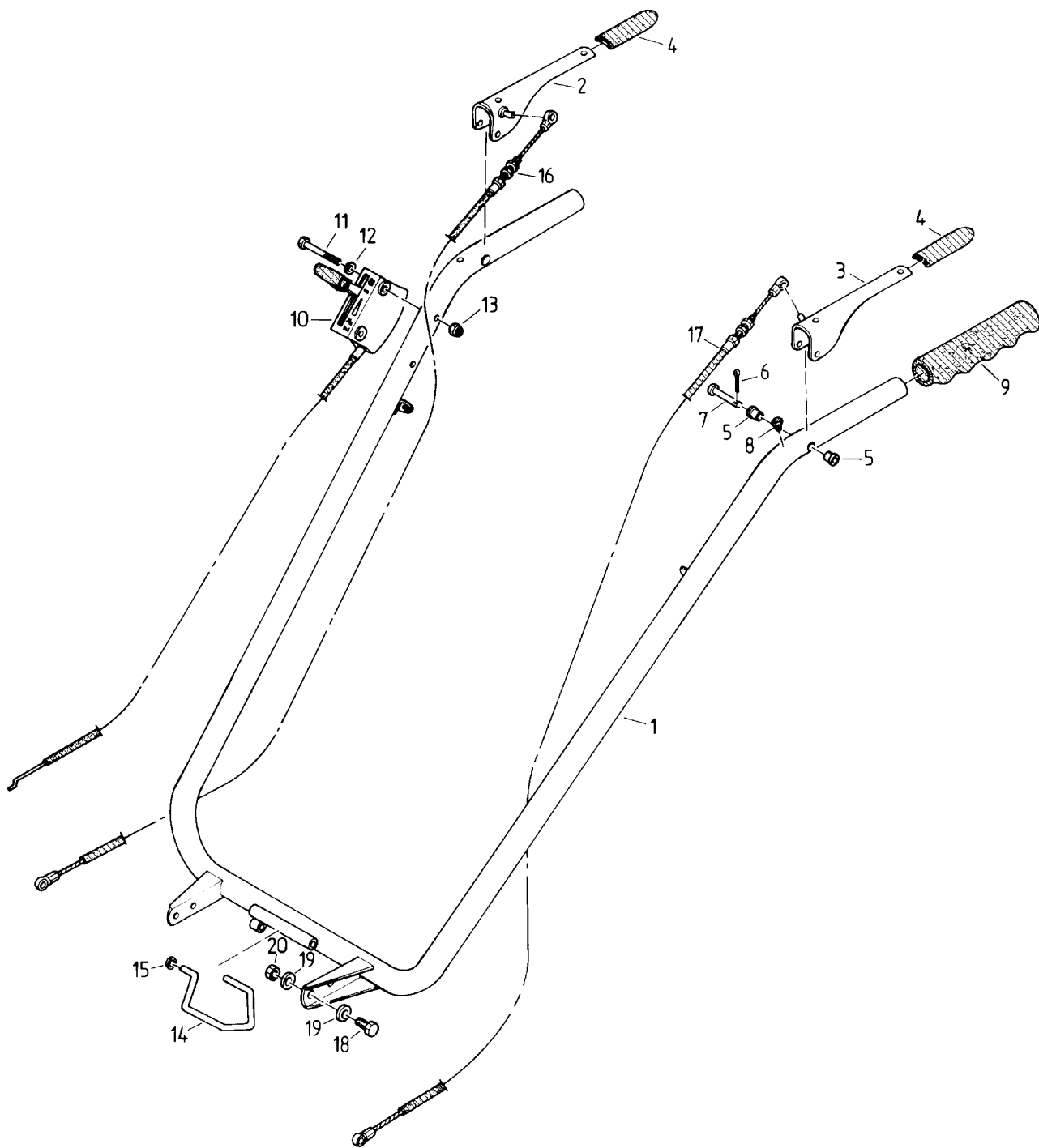
Honda GXV 140
Max.: 3,7 kW / 3600 rpm
Eff.: 3,3 kW / 3000 rpm

Honda GCV 135
Max.: 3,4 kW / 3600 rpm
Eff.: 3,0 kW / 3000 rpm





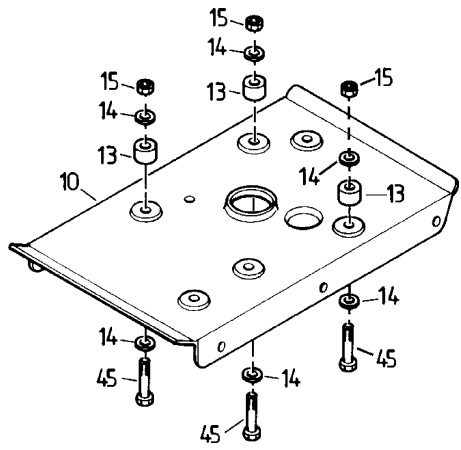

Pos.-Nr. Rep. Pos. Pos. Bilde-Nr.	Bestellnummer Référence Article number Nr. codice Bestillings-Nr.	Anzahl Qté. Quant. Q.tà Antall	Bezeichnung 	Désignation 	Description 	Descrizione 	Benevnelse 	
1	AD-310-144p9010	1	Lenker	Mancheron	Handle bars	Manubrio	Styre	
2	AD-300-154-9005	1	Schalthebel	Levier d'embrayage	Shifting lever	Leva comando	Girstang	
2 a	KD-003-036	1	Aufkleber	Autocollant	Lable	Autoadesivo	Dekal	
3	AA-100-141-9005	1	Schalthebel	Levier d'embrayage	Shifting lever	Leva comando	Girstang	
3 a	KD-003-037	1	Aufkleber	Autocollant	Lable	Autoadesivo	Dekal	
4	HJ-010-015	2	PVC-Handgriff	Poignée	PVC-grip	Manopola PVC	Handtak	
5	HJ-021-009	4	Buchse	Coussinet	Bush	Boccola	Foring	
6	HZ-010-041z	2	Splint	Goupille	Cotter pin	Copiglia	Splint	
7	KK-001-030	2	Bolzen	Boulon	Pin	Bullone	Bolt	
8	HK-005-010	2	Zargenpuffer	Tampon d'encadrement	Rubber stop	Tampone telaio	Demper	
9	HJ-010-018	2	PVC-Handgriff	Poignée	PVC-grip	Manopola PVC	Handtak	
10	AZ-006-093	1	Gashebel kpl.	Accélérateur	Throttle lever	Leva gas	Gashendel	
11	HO-010-062z	2	Sechskantschraube	Vis à six pans	Bolt	Vite esagonale	Sekskantskrue	M 6 x 55
12	HW-010-004z	2	Scheibe	Rondelle	Washer	Rondella	Skive	B 6,4
13	HR-030-004z	2	Sicherungsmutter	Ecrou de sûreté	Locknut	Dado autobloccante	Låsemutter	M 6
14	HI-040-016z	1	Rastfeder	Ressort d'encliquétage	Positioning spring	Molla arresto	Fjær	
15	HU-060-003	1	Federscheibe	Rondelle de ressort	Spring washer	Rondella elastica	Sprengskive	
16	AZ-007-027	1	Kupplungszug für Kehrantrieb	Commande bowden pour entraînement de la brosse rotative	Clutch-cable for brush drive	Cavo frizione per trazione spazzole	Clutchwire for feievalsdrift	
17	AZ-007-029	1	Kupplungszug für Radantrieb	Commande bowden pour entraînement	Clutch cable for drive	Cavo frizione per avanzamento	Clutchwire for fremdrift	
18	HO-020-084z	2	Sechskantschraube	Vis à six pans	Bolt	Vite esagonale	Sekskantskrue	M 8 x 25
19	HW-050-007z	4	Scheibe	Rondelle	Washer	Rondella	Skive	B 8,4
20	HR-010-005	2	Sechskantmutter	Ecrou à six pans	Hexagon nut	Dado esagonale	Sekskantmutter	M 8

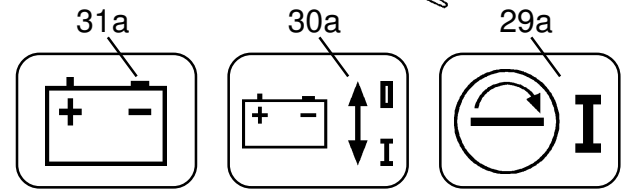
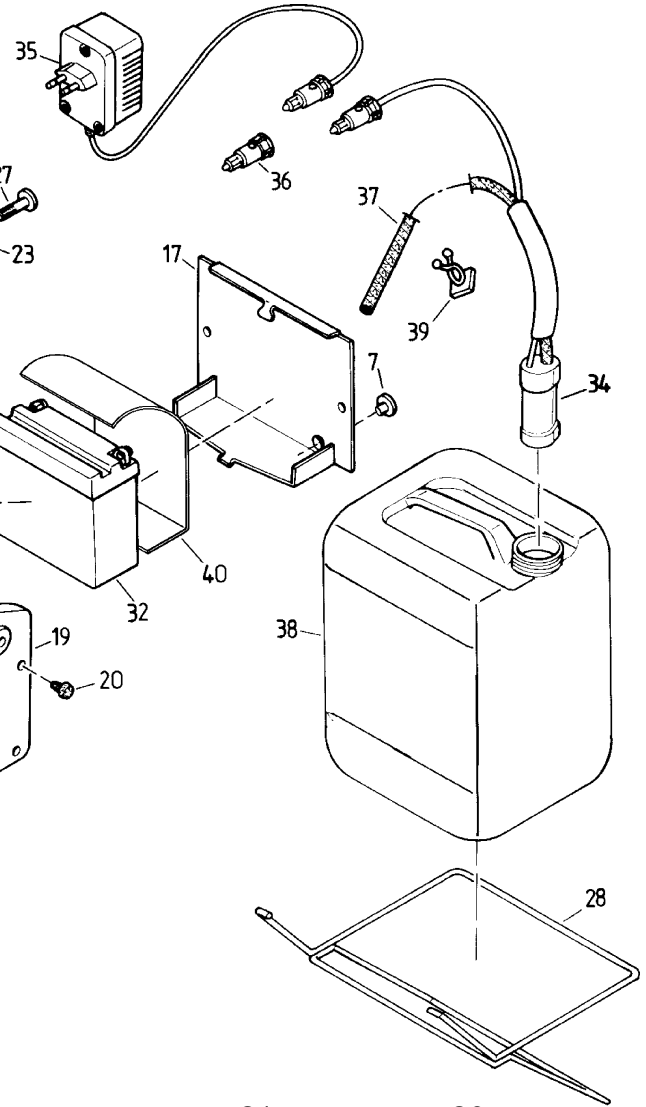
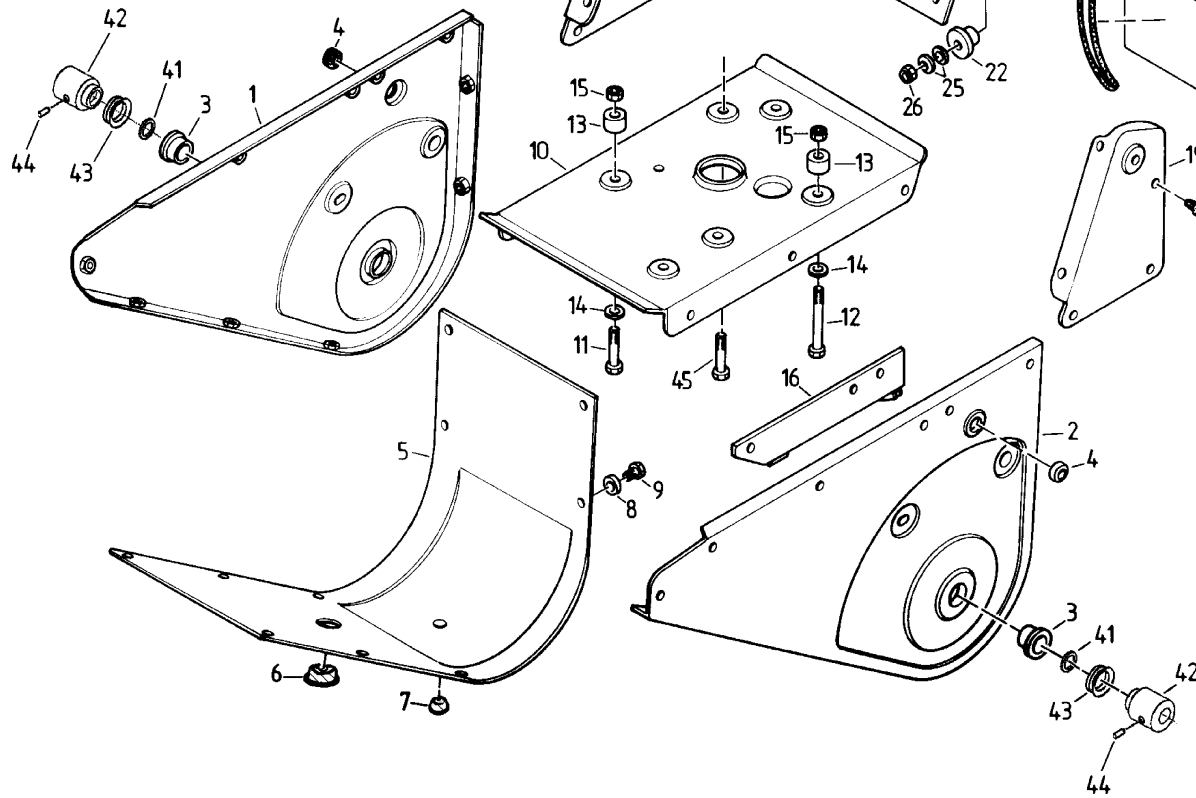

nur für Honda GCV 135



Pos.-Nr. Rep. Pos. Pos. Bilde-Nr.	Bestellnummer Référence Article number Nr. codice Bestillings-Nr.	Anzahl Qté. Quant. Q.tà Antall	Bezeichnung 	Désignation 	Description 	Descrizione 	Benevnelse 	
-	KA-008-002	1	Motor	Moteur	Motor	Motore	Motor	B&S 3, 5HP
-	KA-042-001	1	Motor	Moteur	Motor	Motore	Motor	Honda GXV 140
-	KA-062-001	1	Motor	Moteur	Motor	Motore	Motor	Honda GCV 135
1	AD-310-149-3000	1	Seitenteil rechts	Tôle droite	Side cover right	Fianchetto dx	Sidedeksel høyre	
2	AD-310-150-3000	1	Seitenteil links	Tôle gauche	Side cover left	Fianchetto sy	Sidedeksel venstre	
3	HJ-021-012	2	Bundbuchse	Coussinet	Collar bush	Bussola flangiata	Foring	
4	KO-001-103	2	Durchführungsstülpe	Guide	Rubber bush	Bussola di passaggio	Gjennomføring	
5	DA-180-176-3000	1	Bodenblech	Fond en tôle	Bottom plate	Lamierino	Deksel	
6	HJ-010-006	1	Hutstopfen	Bouchon	Cap	Tappo cieco		
7	HJ-010-030	2	Hutstopfen	Bouchon	Cap	Tappo cieco		
8	HW-050-007z	8	Scheibe	Rondelle	Washer	Rondella	Skive	8,4
9	HO-020-082z	8	Sechskantschraube	Vis à six pans	Hexagon bolt	Vite esagonale	Sekskantskrue	M 8 x 16
10	DA-220-315-3000	1	Motorconsole	Embase moteur	Engine plate	Mensola motore	Motorfeste	
11	HO-010-088z	2	Sechskantschraube	Vis à six pans	Hexagon bolt	Vite esagonale	Sekskantskrue	M 8 x 45(B&S)
12	HO-010-093z	1	Sechskantschraube	Vis à six pans	Hexagon bolt	Vite esagonale	Sekskantskrue	M 8 x 70(B&S)
11+12	HO-090-303z	3	Zollschraube	Vis au pouce	Whitworth-bolt (-screw)	Vite in pollici	Skruer	5/16 x 11/4"(GXV140)
13	DC-181-041z	3	Hülse	Douille	Spacer tube	Boccola	Hylse	(B&S+GCV135)
13	DC-181-041z	4	Hülse	Douille	Spacer tube	Boccola	Hylse	(GXV140)
14	HW-010-007z	3	Scheibe	Rondelle	Washer	Rondella	Skive	B 8,4(B&S+GXV140)
14	HW-010-007z	6	Scheibe	Rondelle	Washer	Rondella	Skive	B 8,4(GCV 135)
15	HR-010-005z	3	Sechskantmutter	écrou à six pans	Hexagon nut	Dado esagonale	Sekskantmutter	M 8
16	AD-310-143g	1	Bowdenzughalter	Serre câble	Cable support	Supporto cavo	Wireholder	
17	DA-180-182-3000	1	Batteriedeckel	Couvercle de batterie	Cover for batterie	Coperchio batteria		
18	AD-310-151-3000	1	Seitenblech rechts	Tôle droite	Mounting shield right	Cofano laterale dx	Sidedeksel høyre	
19	AD-310-152-3000	1	Seitenblech links	Tôle gauche	Mounting shield left	Cofano laterale sx	Sidedeksel venstre	
20	HK-005-010	2	Zargenpuffer	Tampon d'encadrement	Rubber stop	Tampone telaio	Demper	
21	DA-200-504-3000	1	Konsole	Embase	Bracket	Mensola	Feste	
22	DC-241-014z	1	Bundbuchse	Coussinet	Collar bush	Bussola flangiata	Foring	
23	DB-810-009z	1	Verstellstück	Pièce de ajustement	Adjuster	Particolari di regolazione	Stillestykke	
24	HW-010-016z	1	Scheibe	Rondelle	Washer	Rondella	Skive	B 19
25	HI-040-010	2	Tellerfeder	Ressort	Belleville washer	Molla tazza	Fjærskive	
26	HR-030-005z	1	Sicherungsmutter	écrou de sûreté	Locknut	Dado autobloccante	Låsemutter	M 8
27	HP-056-086z	1	Bordwandschraube	Vis	Screw	Vite sponda	Skruer	M 8 x 35
41	HW-080-107	2	Paßscheibe	Rondelle	Shaft spacer	Anello distanziale	Skive	
42	DC-321-020z	2	Stellring	Bague de réglage	Clampring	Collare	Ring	
43	HL-002-031	2	V-Ring	Bague	Ring	Anello	Ring	
44	HP-022-080	2	Gewindestift	Cheville	Slotted set screw	Spina filettata	Gjengestift	M 8 x 10
45	HO-090-305z	1	Zollschraube	Vis au pouce	Whitworth-bolt (-screw)	Vite in pollici	Skruer	5/ 16x11/2"(GXV140)
45	HO-010-089z	3	Sechskantschraube	Vis à six pans	Hexagon bolt	Vite esagonale	Sekskantskrue	M 8 x 50(GCV135)
			Nur für Elektro-Starter	Seulement pour starter électrique	Only for electric starter	Solo per avv. elettrico		
-	KA-008-007	1	Elektro-Starter	Starter électrique	Electric starter	Avv. elettrico		
21	DA-200-508-3000	1	Konsole	Embase	Bracket	Mensola	Feste	
29	KA-008-004	1	Schlüssel-Schalter	Commutator de la clé	Key-switch	Chiave avviamento		
29 a	KD-003-055	1	Aufkleber	Autocollant	Label	Autoadesivo	Dekal	
30	KO-001-104	1	Steckdose	Prise de courant	Socket			
30 a	KD-003-057	1	Aufkleber	Autocollant	Label	Autoadesivo	Dekal	
31	KO-001-068	1	Zugschalter		Pull-switch	Interruttore attirante		
31 a	KD-003-056	1	Aufkleber	Autocollant	Label	Autoadesivo	Dekal	
32	KO-001-067	1	Batterie	Batterie (f)	Batterie	Batteria		
33	HK-002-008	1	Gummiring	Bague caoutchouc	Rubber ring	Anello gomma	Gummiring	
35	AZ-017-029	1	Ladegerät		Charging-equipment	Caricabatteria		
36	KO-001-105	1	Stecker	Fiche (f)	DC-plug			
			Nur für Sprüheinrichtung	Only for spray-equipment	Solo per impianto acqua			
28	AD-311-142z	1	Kanisterhalter	Support de réservoir	Carrier	Supporto bidone		
34	KO-001-071	1	Tauchpumpe	Pompe	Diving pump	Pompa sommersa		
36	KO-001-105	1	Stecker	Fiche (f)	DC-plug			
37	HJ-010-106	1	Plastikschlauch	Outre	Tube	Otre	Slange	
38	HJ-010-092	1	Europa-Kanister		Euro-can			
39	HJ-010116	3	Driller		Driller			
40	HK-005-014	1	Schutzgummi	Bavette en caoutchouc	Rubber lip	Gomma protezione	Gummi	



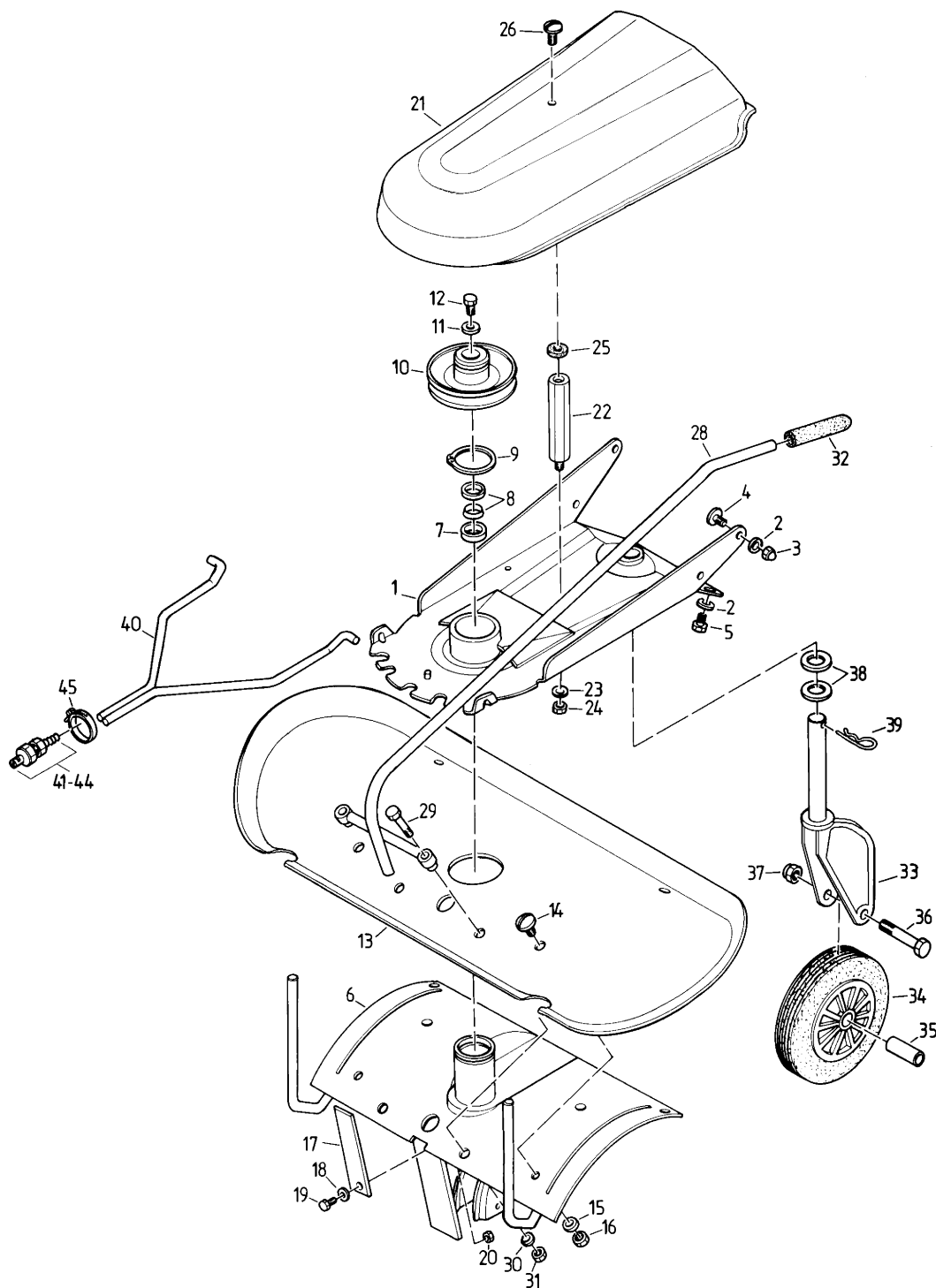

Ausführung Stützradhöhenverstellung (durch Einstellscheiben)



21a



Vor Inbetriebnahme Bedienungsanleitung und Sicherheitshinweise
 durchlesen und beachten
 Before running the equipment read the owners manual and follow
 the Safety Instructions
 Avant mise en marche lisez et regardez attentivement les
 Instructions d'Entretien



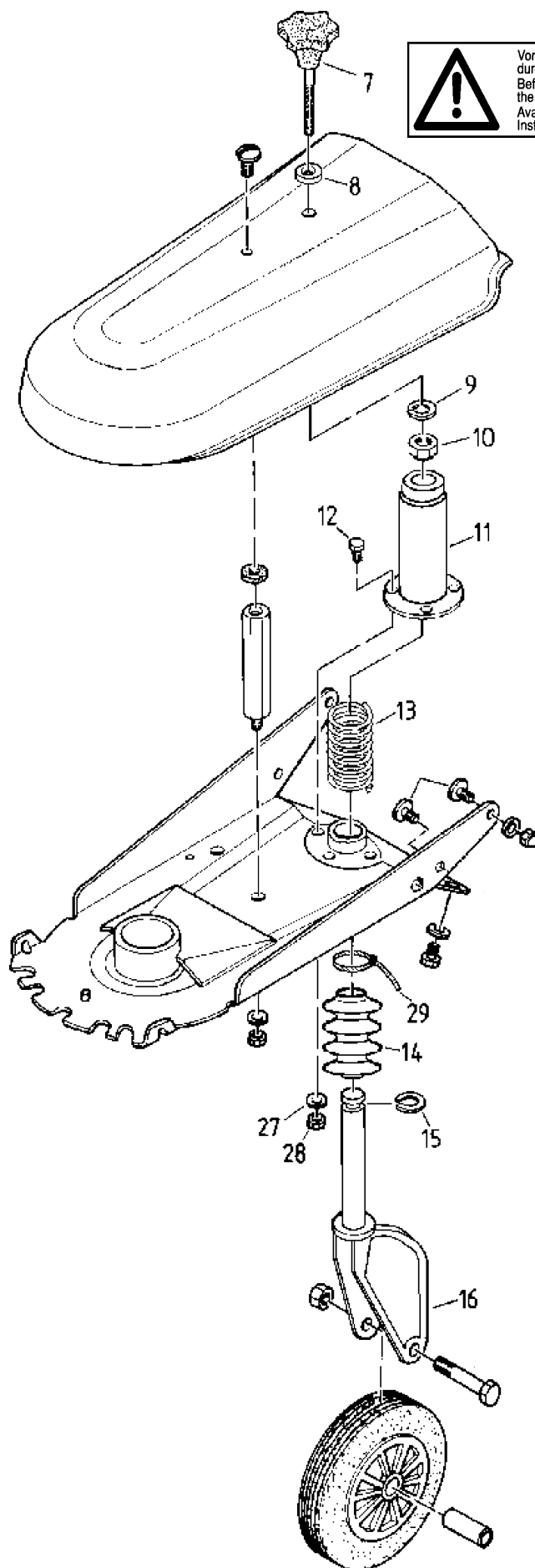

Pos.-Nr. Rep. Pos. Pos. Bilde-Nr.	Bestellnummer Référence Article number Nr. codice Bestillings-Nr.	Anzahl Qté. Quant. Q.tà Antall	Bezeichnung 	Désignation 	Description 	Descrizione 	Benevnelse 	
1	AD-320-145-3000	1	Stellsegment	Pièce de réglage	Shifting segment	Parte regolazione	Stillestykke	8,4
2	HW-050-007z	6	Scheibe	Rondelle	Washer	Rondella	Skive	M 8
3	HR-063-005z	4	Hutmutter	écrou à chapeau	Hexagon cap	nu Dado cieco	Koppmutter	M 8 x 16
4	HP-056-082z	4	Bordwandschraube	Vis	Screw	Vite sponda	Skru	M 8 x 20
5	HO-020-083z	2	Sechskantschraube	Vis à six pans	Hexagon bolt	Vite esagonale	Sekskantskrue	
6	AD-310-147-3000	1	Getriebehalter	Support d'entraînement	Gear stud	Supporto trasmissione	Gearholder	
7	DC-241-015	1	Abstandshülse	Douille d'écartement	Spacer tube	Boccola distanziale	Avstandshylse	
8	KC-001-039	1	Spannelemente-Satz	Tendeur	Tensioner	Tenditore	Strammer	
9	HU-010-048	1	Sicherungsring	Anneau d'arrêt	Retaining ring	Segel	Semering	
10	AZ-001-366-9005	1	Keilriemenscheibe	Poulie	V-belt pulley	Puleggia	Kileremskive	
11	HW-060-009z	1	Scheibe	Rondelle	Washer	Rondella	Skive	A 10,5
12	HO-020-114z	1	Sechskantschraube	Vis à six pans	Hexagon bolt	Vite esagonale	Sekskantskrue	M 10 x 25
13	HJ-010-111-9005	1	Bürstenabdeckung	Tôle de brosses	Brushcover	Coperchio spazzole	Børstedeksel	
14	HP-056-082z	4	Bordwandschraube	Vis	Screw	Vite sponda	Skru	M 8 x 16
15	HW-010-007z	4	Scheibe	Rondelle	Washer	Rondella	Skive	8,4
16	HR-010-005z	4	Sechskantmutter	écrou à six pans	Hexagon nut	Dado esagonale	Sekskantmutter	M 8
17	HI-030-006z	1	Blattfeder	Lame ressort	Blade spring	Molla a balestra	Bladefjær	
18	HW-030-005z	1	Scheibe	Rondelle	Washer	Rondella	Skive	R 6,6
19	HO-020-055z	1	Sechskantschraube	Vis à six pans	Hexagon bolt	Vite esagonale	Sekskantskrue	M 6 x 20
20	HR-010-004z	1	Sechskantmutter	écrou à six pans	Hexagon nut	Dado esagonale	Sekskantmutter	M 6
21	HJ-010-130-3000	1	Keilriemenschutz	Carter de protection	V-belt cover	Protezione cinghia	Kileremsdeksel	
21 a	KD-003-050	1	Aufkleber	Autocollant	Lable	Autoadesivo	Dekal	
22	DV-221-016z	1	Schutzhalter	Support de protecteur	Mounting stud	Supporto protezione	Dekselfeste	
23	HW-060-007z	1	Scheibe	Rondelle	Washer	Rondella	Skive	A 8,4
24	HR-010-005z	1	Sechskantmutter	écrou à six pans	Hexagon nut	Dado esagonale	Sekskantmutter	M 8
25	HJ-010-082	1	Kunststoffscheibe	Rondelle en plastique	Washer	Rondella	Skive	
26	HP-056-083z	1	Bordwandschraube	Vis	Screw	Vite sponda	Skru	M 8 x 20
27	HJ-010-116	2	Driller		Driller			
28	AD-320-141z	1	Schwenkhebel	Levier	Selecting rod	Leva orientamento	Hendel	
29	HO-010-087z	2	Sechskantschraube	Vis à six pans	Hexagon bolt	Vite esagonale	Sekskantskrue	M 8 x 40
30	HW-050-007z	2	Scheibe	Rondelle	Washer	Rondella	Skive	8,4
31	HR-030-005z	2	Sicherungsmutter	écrou de sûreté	Locknut	Dado autobloccante	Låsemutter	M 8
32	HJ-010-015	1	PVC-Handgriff	Poignée	PVC-grip	Manopola PVC	Handtak	
33	AD-320-140z	1	Radträger	Support de roue	(wheel) carrier	Supporto ruota	Hjulholder	
34	AD-320-050TS	1	Rad kpl.	Roue cpl.	Wheel cpl.	Ruota cpl.	Hjul kpl.	
35	DC-181-048z	1	Hülse	Douille	Spacer tube	Boccola	Hylse	
36	HO-010-126z	1	Sechskantschraube	Vis à six pans	Hexagon bolt	Vite esagonale	Sekskantskrue	M 10 x 90
37	HR-010-006z	1	Sechskantmutter	écrou à six pans	Hexagon nut	Dado esagonale	Sekskantmutter	M 10
38	HW-010-017z	11	Scheibe	Rondelle	Washer	Rondella	Skive	B 21
39	KG-011-005z	1	Federstecker	Support de fiche	Hairpin clip	Spina elastica	Låsesplint	
40	AD-311-141z	1	Düsenträger	Support de gicleur	Jet-support	Supporto ugello		
41	KC-001-055	1	Düsenkörper		Jet-body	Corpo ugello		
42	KC-001-057	1	Filter	Filtre	Filter	Filtro	Filter	
43	KC-001-058	1	Düse	Gicleur	Jet	Ugello		
44	KC-001-056	1	Überwurfmutter	Ecrou	Nut	Dado	Mutter	
45	KO-001-102	1	Schlauchschelle		Clip			

Ausführung Stützradhöhenverstellung (Ballengriff)







Vor Inbetriebnahme Bedienungsanleitung und Sicherheitshinweise
durchlesen und beachten
Before running the equipment read the owners manual and follow
the Safety Instructions
Avant mise en marche lisez et regardez attentivement les
Instructions d'Entretien

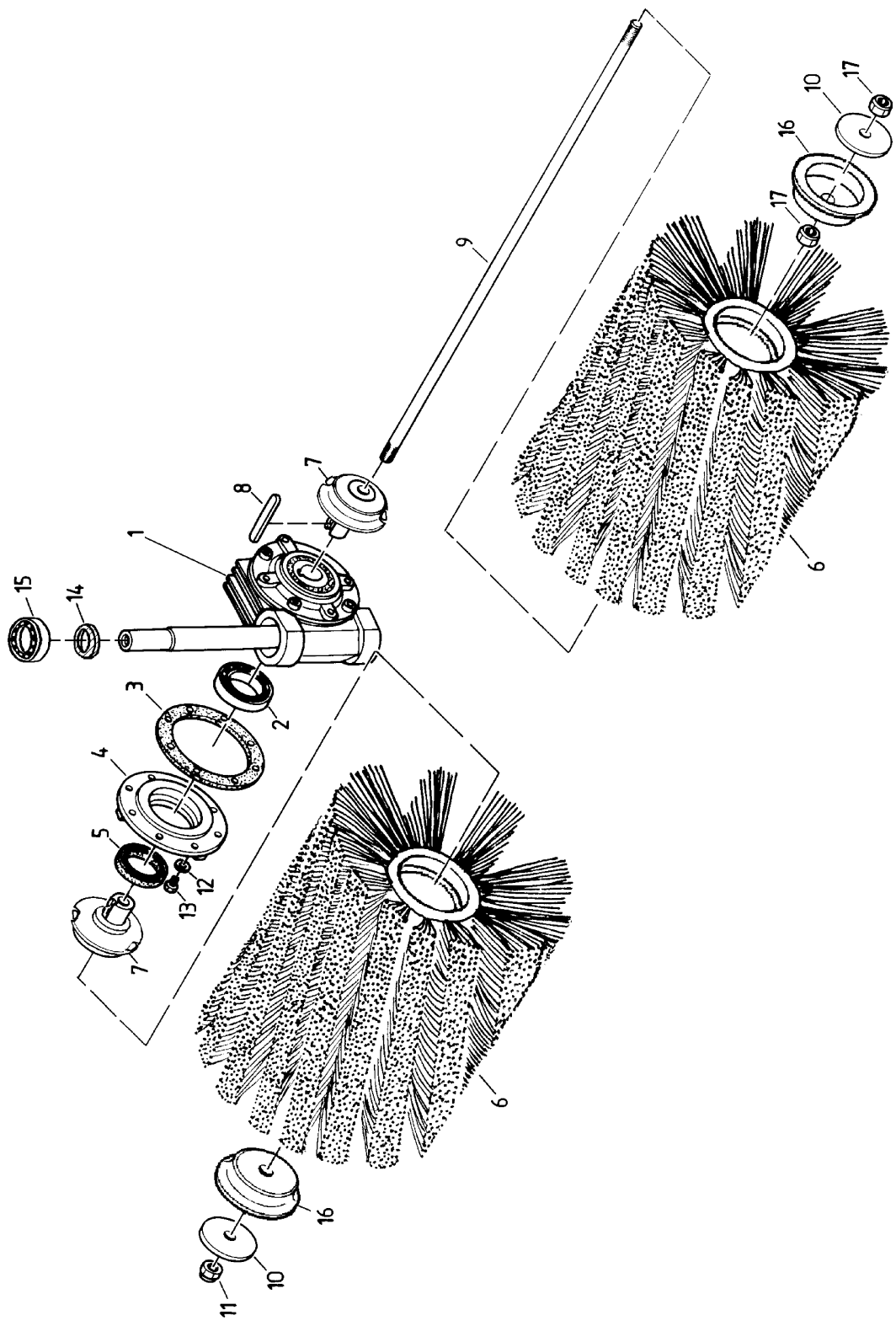



1a

Pos.-Nr. Rep. Pos. Pos. Bilde-Nr.	Bestellnummer Référence Article number Nr. codice Bestillings-Nr.	Anzahl Qté. Quant. Q.tà Antall	Bezeichnung 	Désignation 	Description 	Descrizione 	Benevnelse 	
1 a	KD-003-050	1	Aufkleber	Autocollant	Lable	Autoadesivo	Dekal	
7	HJ-010-121	1	Ballengriff	Poignée	Handle	Leva	Handtak	
8	KO-001-103	1	Durchführungstülle	Guide	Rubber bush	Bussola di passaggio	Gjennomføring	
9	HU-020-020	1	Sicherungsring	Anneau d'arrêt	Retaining ring	Seger	Semering	
10	HR-030-006z	1	Sicherungsmutter	Ecrou de sûreté	Locknut	Dado autobloccante	Låsemutter	M 10
11	AD-330-141-9005	1	Stützradverstellung	Pièce d'ajustement	Adjuster	Particolaridi regolazione	Stillestykke	
12	HO-020-082z	3	Sechskantschraube	Vis à six pans	Bolt	Vite esagonale	Sekskantskrue	M 8 x 16
13	HI-020-008	1	Druckfeder	Ressort de pression	Compression spring	Molla compressione	Fjær	
14	HK-005-023	1	Faltenbalg	Bavette en caoutchouc	Rubber protection	Gomma protezione	Gummi	
15	KC-001-074z	1	Spezialscheibe	Rondelle spéciale	Special washer	Rondella speciale	Spezialskive	B 21
16	AD-320-140z	1	Radträger	Support de roue	Carrier	Supporto ruota	Hjulholder	
27	HW-010-007z	3	Scheibe	Rondelle	Washer	Rondella	Skive	B 8,4
28	HR-010-005z	3	Sechskantmutter	Ecrou de sûreté	Locknut	Dado autobloccante	Låsemutter	M 8
29	HJ-010-143	1	Kabelbinder	Collier en platiq	Strap	Legaccio		

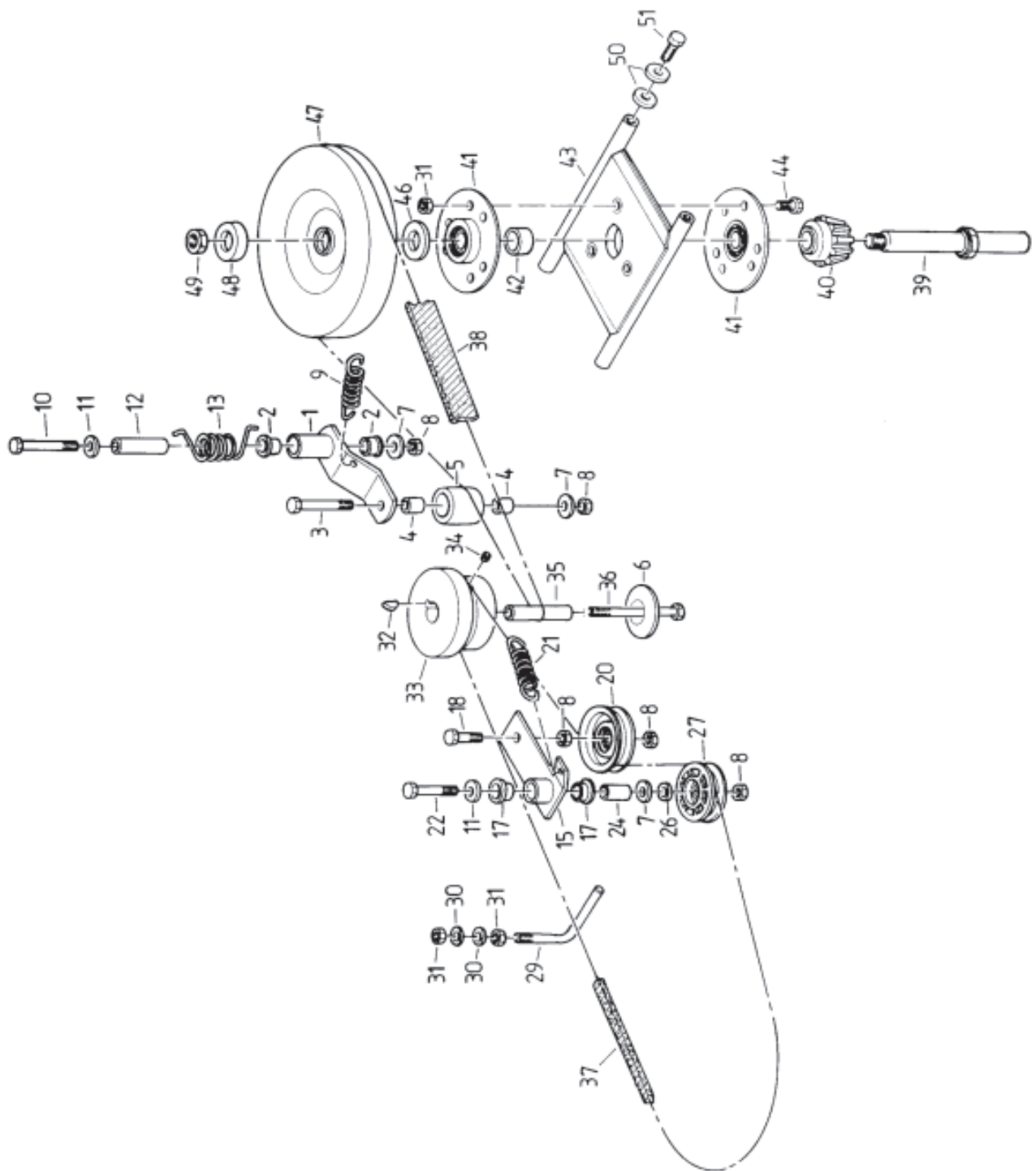







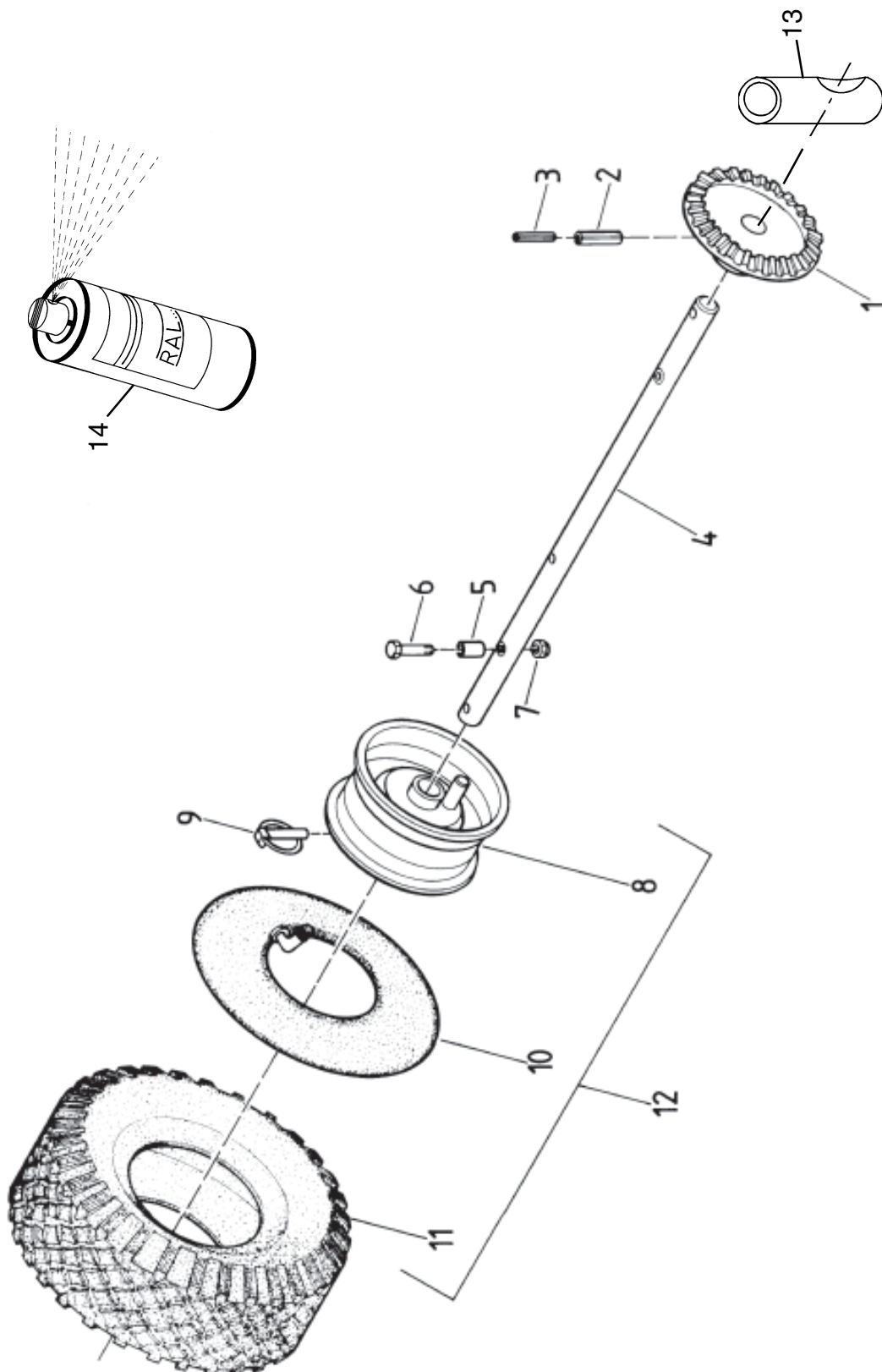



Pos.-Nr. Rep. Pos. Pos. Bilde-Nr.	Bestellnummer Référence Article number Nr. codice Bestillings-Nr.	Anzahl Qté. Quant. Q.tà Antall	Bezeichnung 	Désignation 	Description 	Descrizione 	Benevnelse 	
1	AZ-016-019	1	Schneckenetriebe, kpl.	Boîte de vitesses, cpl.	Gear drive, cpl.	Trasmissione, cpl.	Gear, kpl.	
2	HA-010-061	2	Kugellager	Roulement à billes	Ball bearing	Cuscinetto a sfere	Kulelager	
3	HL-002-030	2	Dichtung	Joint	Sealing	Guarnizione	Pakning	
4	KC-001-063	2	Flansch	Flasque	Flange	Flangia	Flens	
5	HL-001-040	2	Wellendichtring	Baque	Ring	Anello	Ring	
6	AD-090-082	1	Kehrbürstensatz Nylon	Paire des brosses, nylon	Pair of brushes, nylon	Set spazzole, nylon	Børste, nylon	
7	AD-330-142-9005	2	Mitnehmer	Entraîneur	Drive pin	Trascinatore	Medbringer	
8	KH-010-013	1	Paßfeder	Ressort	Parallel key	Linguetta	Kile	
9	DC-100-072z	1	Achse	Arbre	Axle	Ase	Aksel	
10	DA-332-007-9005	2	Scheibe	Rondelle	Washer	Rondella	Skive	
11	HR-030-007z	1	Sicherungsmutter	Ecrou de sûreté	Locknut	Dado autobloccante	Låsemutter	M 12
12	HW-010-004z	6	Scheibe	Rondelle	Washer	Rondella	Skive	B 6,4
13	HO-020-053z	6	Sechskantschraube	Vis à six pans	Bolt	Vite esagonale	Sekskantskrue	M 6 x 12
14	HK-002-007	1	O-Ring	Baque	O-ring	O-ring	O-ring	
15	HA-030-005	1	Kugellager	Roulement à billes	Ball bearing	Cuscinetto a sfere	Kulelager	
16	DA-241-024-9005	2	Kappe	Couvercle	Cap	Coperchietto	Kapp	
17	HR-010-007z	2	Sechskantmutter	Ecrou à six pans	Hexagon nut	Dado esagonale	Sekskantmutter	M 12



Pos.-Nr. Rep. Pos. Pos. Bilde-Nr.	Bestellnummer Référence Article number Nr. codice Bestillings-Nr.	Anzahl Qté. Quant. Q.tà Antall	Bezeichnung 	Désignation 	Description 	Descrizione 	Benevnelse 
1	AD-310-114z	1	Flachriemenspanner	Tendeur de courroie plate	Belt tensioner	Tendicinghia	Flatremstrammer
2	HJ-021-011	2	Bundbuchse	Coussinet	Collar bush	Bussola flangiata	Foring
3	HO-010-122z	1	Sechskantschraube	Vis à six pans	Hexagon bolt	Vite esagonale	Sekskantskrue M 10 x 65
4	DM-040-002	2	Abstandshülse	Douille d'écartement	Spacer tube	Boccola distanziale	Avstandshylse
5	AZ-002-002	1	Rolle	Galet	pulley oder castor	Rullo	Rull
6	DA-180-173z	1	Scheibe	Rondelle	Washer	Rondella	Skive
7	HW-010-009z	3	Scheibe	Rondelle	Washer	Rondella	Skive B 10,5
8	HR-010-006z	5	Sechskantmutter	écrou à six pans	Hexagon nut	Dado esagonale	Sekskantmutter M 10
9	HI-010-003-9005	1	Zugfeder	Ressort de traction	Extension spring	Molla di trazione	Fjær
10	HO-010-124z	1	Sechskantschraube	Vis à six pans	Hexagon bolt	Vite esagonale	Sekskantskrue M 10 x 75
11	HW-050-009z	2	Scheibe	Rondelle	Washer	Rondella	Skive 10,5
12	DC-131-030z	1	Abstandshülse	Douille d'écartement	Spacer tube	Boccola distanziale	Avstandshylse
13	HI-040-017z	1	Drehfeder	Ressort	Spring	Molla	Fjær
15	AD-310-140z	1	Spanner	Tendeur	Tensioner	Tenditore	Strammer
17	HJ-021-011	2	Bundbuchse	Coussinet	Collar bush	Bussola flangiata	Foring
18	HO-020-115z	1	Sechskantschraube	Vis à six pans	Hexagon bolt	Vite esagonale	Sekskantskruer M 10 x 30
20	AZ-002-001	1	Spannrolle	Galet tendeur	Tensioning pulley	Rullo tenditore	Strammerull
21	HI-010-015-9005	1	Zugfeder	Ressort de traction	Extension spring	Molla di trazione	Fjær
22	HO-010-120z	1	Sechskantschraube	Vis à six pans	Hexagon bolt	Vite esagonale	Sekskantskrue M 10 x 55
24	DC-131-029z	1	Abstandshülse	Douille d'écartement	Spacer tube	Boccola distanziale	Avstandshylseter
26	HW-020-009z	1	Scheibe	Rondelle	Washer	Rondella	Skive 10,5
27	AZ-002-005	1	Spannrolle	Galet tendeur	Tensioning pulley	Rullo tenditore	Strammerull
29	DC-061-007z	1	Führung	Guidage	Guide	Guida	Føring
30	HW-010-007z	2	Scheibe	Rondelle	Washer	Rondella	Skive B 8,4
31	HR-010-005z	5	Sechskantmutter	écrou à six pans	Hexagon nut	Dado esagonale	Sekskantmutter M 8
32	KH-020-102	1	Scheiben-Paßfeder	Rondelle d'ajustage	Woodruff-key	Linguetta a disco	Kile
33	DX-001-060e	1	Keilriemenscheibe	Poulie	V-belt pulley	Puleggia	Kileremskive
34	HP-022-051z	1	Gewindestift	Cheville	Slotted set screw	Spina filettata	Gjengestift M 6 x 8
35	DM-050-001	1	Hülse	Douille	Spacer tube	Boccola	Hylse
36	HO-090-323z	1	Zollschraube	Vis au pouce	Whitworth-bolt (-screw)	Vite in pollici	Skrue 3 / 8"
37	HB-112-267	1	Spezialkeilriemen	Courroie spéciale	Special V-belt	Cinghia speciale	Kilerem spesial
38	HC-010-049	1	Flachriemen	Courroie plate	Belt	Cinghia piana	Flatrem
39	DV-261-002	1	Welle	Lame	Shaft	Albero	Aksel
40	DX-003-027	1	Kegelrad	Pignon conique	Pinion gear	Pignone	Drev
41	AA-140-103z	2	Flansch	Flasque	Flange	Flangia	Flens
42	DN-100-024	1	Distanzrohr	Tuyau d'entretoise	Spacer tube	Tube distanziale	Distanserør
43	AD-310-142g	1	Lagerkonsole	Palier	Bearing console	Mensola cuscinetto	Lagerkonsol
44	HO-020-085z	3	Sechskantschraube	Vis à six pans	Hexagon bolt	Vite esagonale	Sekskantskrue M 8 x 30
46	DC-361-029	1	Distanzring	Entretoise	Spacer ring	Anello distanziale	Ring
47	HH-010-006	1	Flachriemenscheibe	Poulie	Belt rim	Puleggia cinghia piana	Flatremskivet
48	DC-361-030	1	Haltering	Bague	Ring	Anello	Ring
49	HR-010-009z	1	Sechskantmutter	écrou à six pans	Hexagon nut	Dado esagonale	Sekskantmutter M 16
50	HW-050-007z	8	Scheibe	Rondelle	Washer	Rondella	8,4
51	HO-020-083z	4	Sechskantschraube	Vis à six pans	Hexagon bolt	Vite esagonale	Sekskantskrue M 8 x 20



Pos.-Nr. Rep. Pos. Pos. Bilde-Nr.	Bestellnummer Référence Article number Nr. codice Bestillings-Nr.	Anzahl Qté. Quant. Q.tà Antall	Bezeichnung 	Désignation 	Description 	Descrizione 	Benevnelse 	
1	DX-003-026g	1	Tellerrad	Roue conique	Bevel gear	Corona	Kronhjul	
2	HX-010-240	1	Spannstift	Goupille de serrage	Spring pin	Spina elastica	Spennstift	6 x 40
3	HX-010-116	1	Spannstift	Goupille de serrage	Spring pin	Spina elastica	Spennstift	3,5 x 40
4	DC-181-040z	1	Achse	Arbre	Axle	Asse	Aksel	
5	DM-030-007	2	Abstandshülse	Douille d'écartement	Spacer tube	Boccola distanziale	Abstandshülse	
6	HO-010-087z	2	Sechskantschraube	Vis à six pans	Bolt	Vite esagonale	Sekskantskrue	M 8 x 40
7	HR-030-005z	2	Sicherungsmutter	Ecrou de sûreté	Locknut	Dado autobloccante	Låsemutter	M 8
8	AZ-009-014	2	Felge	Jante	Rim	Cerchio	Felg	
9	AZ-008-001z	2	Klappsplint	Goupille	Hinged pin	Spina sicurezza	Orepinne	
10	HN-032-001	2	Schlauch	Outre	Tube	Camera aria	Slange	3.00-4/4.00-4
11	HN-022-006	2	Decke	Enveloppe	Cover	Coperchio	Dekk	4.00-4
12	AD-300-052	2	Rad kpl.	Roue cpl.	Wheel cpl.	Routa cpl.	Hjul kpl.	
13	HJ-010-146	1	t-Lager					
14	KP-002-001	400 ml	Farbsprühdose, rot	Bombe de peinture, rouge	Spray paint tin, red	Vernice spray da ritocco, rosso	Sprayboks, rod	RAL 3000
14	KP-002-002	400 ml	Farbsprühdose, weiß	Bombe de peinture, blanche	Spray paint tin, white	Vernice spray da ritocco, bianco	Sprayboks, hvit	RAL 3000
14	KP-002-004	400 ml	Farbsprühdose, schwarz	Bombe de peinture, noire	Spray paint tin, black	Vernice spray da ritocco, nero	Sprayboks, sort	RAL 3000

Pos.-Nr. Rep. Pos. Pos. Bilde-Nr.	Bestellnummer Référence Article number Nr. codice Bestillings-Nr.	Anzahl Qté. Quant. Q.tà Antall	Bezeichnung 	Désignation 	Description 	Descrizione 	Benevnelse 		
Schutzplane / Toile de protection / Brush cover / Grembialino de protezione									
1	HJ-010-144	1	Schutzplane rechts	Toile de protection droite	Brush cover right	Grembialino di protezione			
2	HJ-010-145	1	Schutzplane links	Toile de protection gauche	Brush cover left	Grembialino di protezione			
3	AY-029-140-9005	1	Rahmenträger	Support de la toile	Coverframe				
4	DB-190-056-9005	2	Rahmen	Corps	Body				
5	HO-020-055z	2	Sechskantschraube	Vis à six pans	Hexagon bolt	Vite esagonale	Sekskantskrue		M 6 x 20
6	HR-010-004z	2	Sechskantmutter	écrou à six pans	Hexagon nut	Dado esagonale	Sekskantmutter		M 6
7	HW-010-004z	2	Scheibe	Rondelle	Washer	Rondella	Skive		DIN 125
Kehrgutbehälter / Récupérateur de produits balayés / Dirt-container / Cassonetto raccogli sporco / Beholder									
1	AD-310-154-9005	1	Rohrrahmen	Corps tuyau	Tube body	Cornice tubo			
2	HJ-010-119	1	Oberschale	Coque en haut	Upper shell	Buccia			
3	HJ-010-118	1	Unterschale	Coque en bas	Lower shell				
4	AD-310-059TS	1	Gummileiste	Bande caoutchouc	Rubber bar	Lista gomma	Gummilist		
5	HP-056-053z	6	Bordwandschraube	Vis	Screw	Vite sponda	Skru		M 6 x 12
6	HP-056-054z	10	Bordwandschraube	Vis	Screw	Vite sponda	Skru		M 6 x 16
7	HW-060-004z	16	Scheibe	Rondelle	Washer	Rondella	Skive		A 6,4
8	HR-010-004z	18	Sechskantmutter	écrou à six pans	Hexagon nut	Dado esagonale	Sekskantmutter		M 6
9	AD-310-153z	4	Schwinge	Aile	Wing	Braccio oscillante			
10	HN-040-019	4	Räder	Roues	Wheels	Ruote			
11	HW-010-011z	4	Scheibe	Rondelle	Washer	Rondella	Skive		B 13
12	HU-060-012	4	Federscheibe	Rondelle de ressort	Spring washer	Rondella elastica	Sprengskive		
9-12	AD-310-057	4	Lenkrolle kpl.	Roulette de guidage cpl.	Castor cpl.	Ruotino pivottante cpl.	Styrerull kpl.		
13	AD-310-053	1	Ausschwenkbügel kpl.	Bride cpl.	Handle cpl.	Staffa cpl.	Bøyle kpl.		
14	HP-056-055z	2	Bordwandschraube	Vis	Screw	Vite sponda	Skru		M 6 x 20
15	HW-010-004z	2	Scheibe	Rondelle	Washer	Rondella	Skive		A 6,4
16	DC-321-016z	2	Bundbuchse	Coussinet	Collar bush	Bussola flangiata	Foring		
17	HJ-010-122	2	Blindstopfen	Bouchon	Cap	Tappo			
Schneeräumschild / Lame à neige / Snow-shield / Lama da neve / Snøbrett									
1	AE-002-140-3000	1	Schneeräumschild	Lame à neige	Snow-shield	Lama da neve	Snøbrett		
2	HJ-010-120	2	Vierkantstopfen	Bouchon carre	Plug	Tappo quadro			
3	HR-030-005z	2	Sicherungsmutter	écrou de sûreté	Locknut	Dado autobloccante	Låsemutter		M 8
4	HN-040-020	2	Räder	Roues	Wheels	Ruote			
5	HO-010-091z	2	Sechskantschraube	Vis à six pans	Hexagon bolt	Vite esagonale	Sekskantskrue		M 8 x 60
6	DC-321-016z	2	Bundbuchse	Coussinet	Collar bush	Bussola flangiata	Foring		

EG-Konformitätserklärung

entsprechend der EG-Richtlinie 89/392/EWG

Wir,

Julius Tielbürger GmbH & Co. KG, Maschinenfabrik, Postdamm 12, D-32351 Stemwede-Oppenwehe

erklären in alleiniger Verantwortung, daß das Produkt

Kehrmaschine tk 32

ab Serien-Nr.: AD-321-040TS/IM/KF/BK-0001 bzw. AD-322-040TS/Im/KF/BK-0001 bzw. AD-323-040TS/IM/KF/BK-0001, AD-324-040TS/IM/BK/KF-0001

auf das sich diese Erklärung bezieht, den einschlägigen grundlegenden Sicherheits- und Gesundheitsanforderungen der EG-Richtlinie 89/392/EWG sowie den Anforderungen der anderen einschlägigen EG-Richtlinien EMV-89/336/EWG entspricht.
Zur sachgerechten Umsetzung der in den EG-Richtlinien genannten Sicherheits- und Gesundheitsanforderungen wurden folgende Normen und technische Spezifikationen herangezogen: DIN EN ISO 9001.

Déclaration de conformité pour la CEE

conforme à la directive de la CEE 89/392/CEE

Nous,

Julius Tielbürger GmbH & Co. KG, Maschinenfabrik, Postdamm 12, D-32351 Stemwede-Oppenwehe

déclarons sous notre seule responsabilité que le produit

Balayeus tk 32

de no. de serie: AD-321-040TS/IM/KF/BK-0001 bzw. AD-322-040TS/Im/KF/BK-0001 bzw. AD-323-040TS/IM/KF/BK-0001, AD-324-040TS/IM/BK/KF-0001

faisant l'objet de la déclaration est conforme aux prescriptions fondamentales en matière de sécurité et de santé stipulées dans la Directive de la CEE 89/392/CEE ainsi qu'aux prescriptions des autres Directives de la CEE établies dans ce domaine: EMV-89/336/EWG.
Pour mettre en pratique dans les règles de l'art les prescriptions en matière de sécurité et de santé stipulées dans les Directives de la CEE, il a été tenu compte des normes et des spécifications techniques suivantes: DIN EN ISO 9001.

EC Certificate of Conformity

conforming to EEC Directions 89/392

We,

Julius Tielbürger GmbH & Co. KG, Maschinenfabrik, Postdamm 12, D-32351 Stemwede-Oppenwehe

declare in sole responsibility, that the product

Rotary brush tk 32

from series-number: AD-321-040TS/IM/KF/BK-0001 bzw. AD-322-040TS/Im/KF/BK-0001 bzw. AD-323-040TS/IM/KF/BK-0001, AD-324-040TS/IM/BK/KF-0001

to which this certificate applies, conforms to the basic safety and health requirements to EEC Directions 89/392 and to the other relevant EEC Directions: EMV-89/336/EWG.
To effect correct application of the safety and health requirements stated in the EEC Directions, the following standards and technical specifications were consulted: DIN EN ISO 9001.

Certificato di conformità comunitario

rispondente alla normativa CEE 89/392/CEE

Noi,

Julius Tielbürger GmbH & Co. KG, Maschinenfabrik, Postdamm 12, D-32351 Stemwede-Oppenwehe

dichiariamo sotto la nostra piena responsabilità che il prodotto

Spazzolatrice tk 32

da macchina nr.: AD-321-040TS/IM/KF/BK-0001 bzw. AD-322-040TS/Im/KF/BK-0001 bzw. AD-323-040TS/IM/KF/BK-0001, AD-324-040TS/IM/BK/KF-0001

cui la presente dichiarazione si riferisce, risponde alla normativa CEE/89/392 in materia di sicurezza e sanità, nonché a quanto richiesto dalle altre direttive CEE: EMV-89/336/EWG.
Per un'opportuno riscontro nell'ambito della normativa CEE delle norme di sicurezza e sanitarie sopra citate, sono state consultate le seguenti norme e specifiche tecniche: DIN EN ISO 9001.

EF-konformitetserklaering

tilsvarer EF-retningslinje 89/392/EWG

Vi,

Julius Tielbürger GmbH & Co. KG, Maschinenfabrik, Postdamm 12, D-32351 Stemwede-Oppenwehe

erklærer i alenehavende ansvar, at produktet

Feiemaskin tk 32

fra maskinnr.: AD-321-040TS/IM/KF/BK-0001 bzw. AD-322-040TS/Im/KF/BK-0001 bzw. AD-323-040TS/IM/KF/BK-0001, AD-324-040TS/IM/BK/KF-0001

som denne erklæringen dreier seg om, oppfyller de vedkommende grunnleggende sikkerhets- og sunnhetskrav i EF-retningslinjen 89/392/EWG. Så vel som kravene i de andre vedkommende EF-retningslinjene EMV-89/336/EWG.
For saklig riktig omsetning av sikkerhets- og sunnhetskravene som er oppført i EF-retningslinjene ble følgende normer og tekniske spesifikasjoner benyttet: DIN EN ISO 9001.

Stemwede, den 30.09.1999

Julius Tielbürger
GmbH & Co. KG