



G-Force 2200

PARTS LIST



Model No. 1522-2 G-Force 2200
Manual No. 102679GS Rev 0



Alternator Outlet Panel

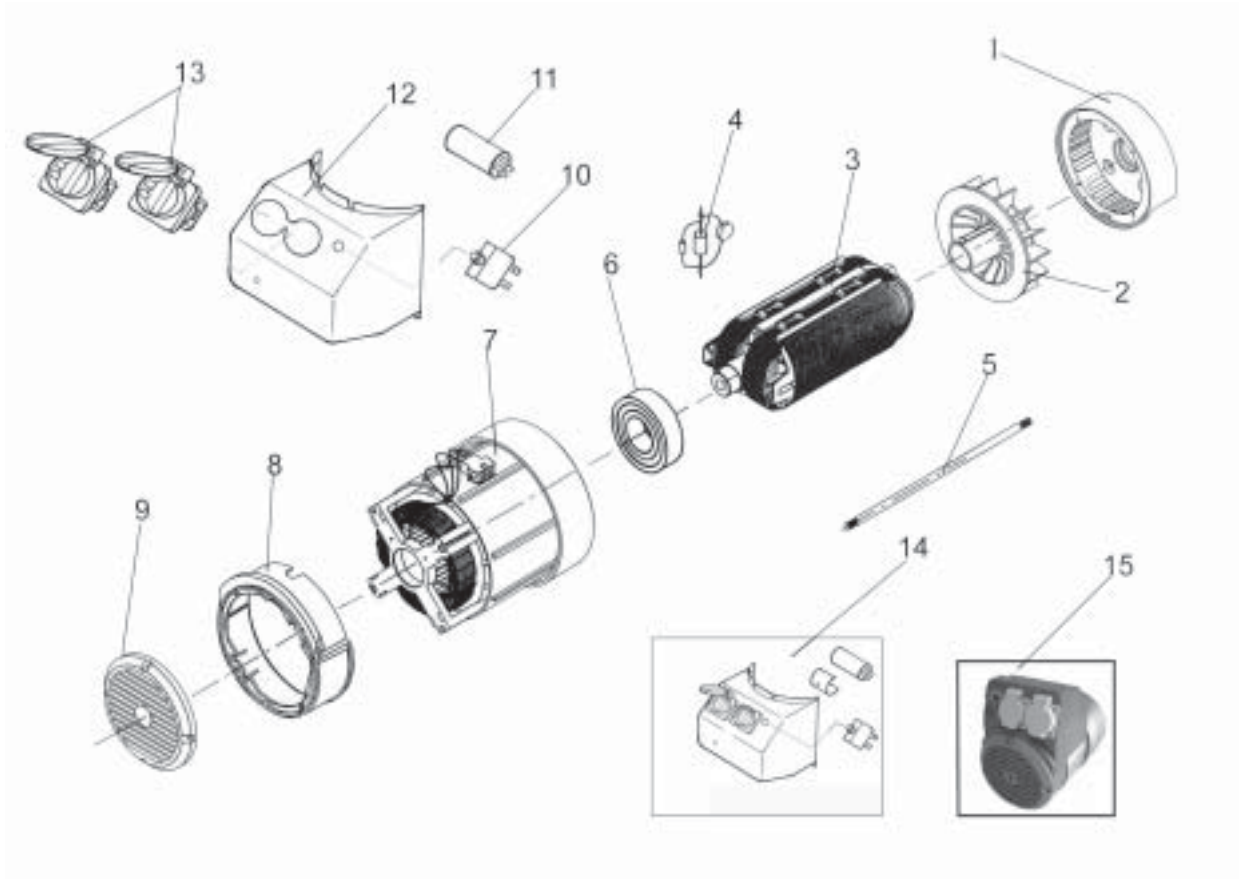

ITEM	PARTID	PARTDESCRIPTION	QTY
1	102059GS	FLANGE ALTERNATOR	1
2	102046GS	FAN ROTOR SINCRO R80	1
3	102056GS	ROTOR SINCRO R80	1
4	102052GS	DIODE & VARISTOR ASSY	1
5	102057GS	ROTOR BOLT SINCRO R80	1
6	102063GS	BEARING ROTOR	1
7	102058GS	STATOR SINCRO R80	1
8	102060GS	COWLING ALTERNATOR R80	1
9	102061GS	END COVER ALTERNATOR R80	1
10	102132GS	CIRCUIT BREAKER 10A	1
11	102053GS	CAPACITOR 16UF	1
12	102469GS	OUTLET BOX BLANK (NO FITTINGS) R80 (B5281-B)	1
13	102030GS	SOCKET OUTLET	2
14	102470GS	OUTLET BOX SINCRO VERTICAL G/S	1
15	102484GS	ALTERNATOR SINCRO R80 VERTICAL	1



Frame and Fittings

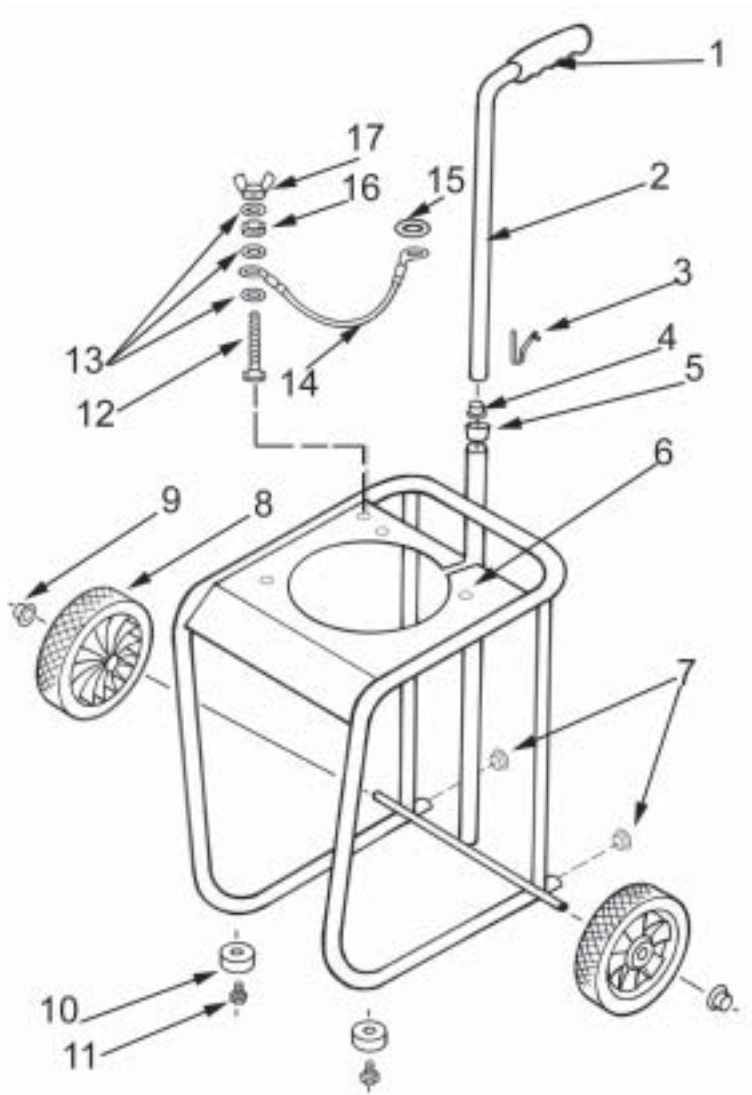

ITEM	PARTID	PARTDESCRIPTION	QTY
1	102625GS	GRIP BLACK (HANDLE GRIP)	1
2	102622GS	HANDLE (VT FRAME)	1
3	102584GS	SPRING CLIP 7/8" TUBE	1
5	102624GS	ANTI RATTLE RING	1
6	102621GS	CRADLE YELLOW	1
7	102623GS	PLUG BLACK 7/8" / 18SWG TUBE	3
8	102461GS	WHEEL 7"	2
9	102462GS	PUSHNUT	2
10	102463GS	VIBRATION MOUNT EG SERIES	2
11	102229GS	SCREW MACHINE HHD M8-1.25*16MM	2
12	102037GS	SCREW SET M6-1.0X25MM PLATED	1
13	102021GS	WASHER SHAKEPROOF 1/4" & M6 INT	3
14	102378GS	LEAD EARTH ASSY 125MM	1
15	102024GS	WASHER SHAKEPROOF M8 INT	1
16	102028GS	NUT FULL M6-1.0	1
17	102036GS	NUT WING M6-1.0	1



Panel Wiring Diagram

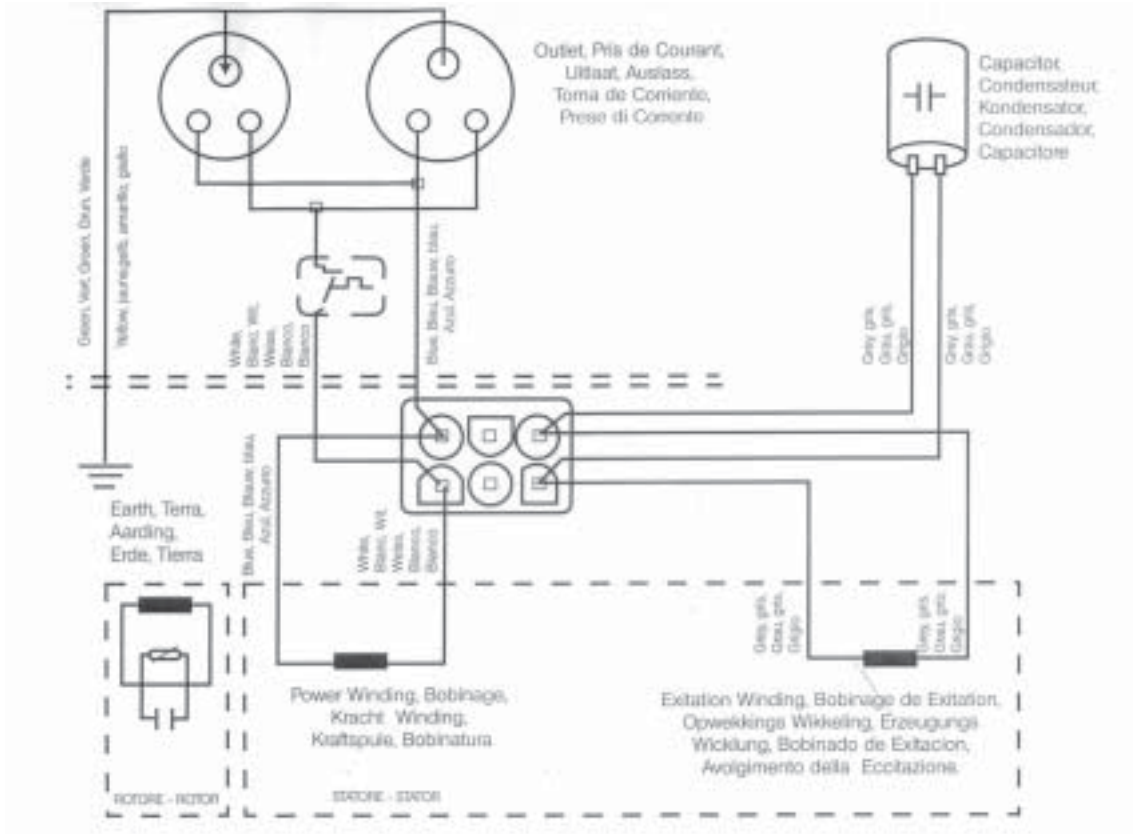

RESISTANCE VALUES AT 20 °C

POWER 2.2 OHMS

EXCITATION 5.0 OHMS

Decal & Manual Items *Not Illustrated

102678GS	DECAL G-FORCE 2200	1
102076GS	DECAL ELECTRICAL HAZARD	1
102041GS	DECAL CAUTION HOT	1
102048GS	DECAL GND	1
102077GS	DECAL WARNING READ MANUAL	1
102590GS	MANUAL GENERIC-GFORCE	1