

# **PARTNER**

## **P 214**



**SPARE PARTS LEAFLET  
ERSATZ TEILE KATALOG**

---

*ET. List = 200 00 00 - 11*

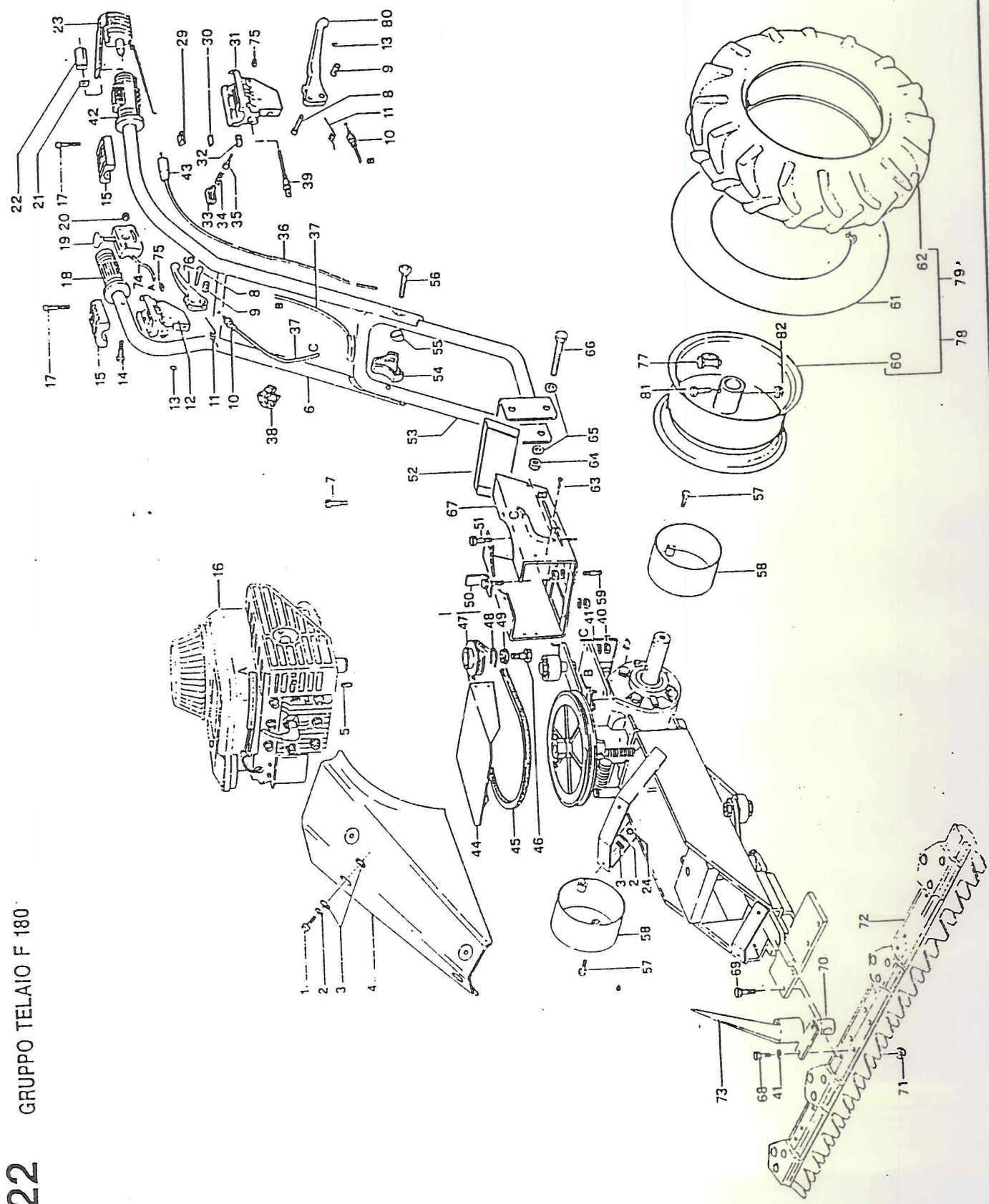

POS.	CODICE	DESCRIZIONE	Q.TA'	POS.	CODICE	DESCRIZIONE	Q.TA'
1	02.006.0.048.0	Vite TCB M6X25	4	44	02.222.0.044.0	Prot.puleggia	1
2	02.006.0.049.0	Rosetta comune	8	45	02.216.0.045.0	Cinghia	1
3	02.002.0.005.0	Rondella	12	46	02.064.0.080.0	Vite TE	1
4	02.216.0.004.0 <sup>03</sup>	Protezione ruote	1	47	02.216.0.047.0	Puleggia	1
5	02.014.0.089.0	Chiavetta	1	48	02.216.0.048.0	Seeger 122	1
6	02.222.0.006.0	Stegola	1	49	02.216.0.049.0	Rondella	1
7	02.002.0.016.0	Vite TE 8x30	3	50	02.216.0.050.0	Staffa	1
8	02.222.0.008.0	Perno leva	2	51	02.002.0.018.0	Vite	1
9	02.222.0.009.0	Barilotto	2	52	02.222.0.052.0	Coperchietto	1
10	02.222.0.010.0	Colonna con reg.	2	53	02.216.0.053.0	Supporto	1
11	02.222.0.011.0	Molla	2	54	02.219.0.059.0	Pomello	2
12	02.222.0.012.0	Supporto leva	1	55	02.014.0.064.0	Rondella	2
13	02.222.0.013.0	Seeger	2	56	02.219.0.060.0	Vite	2
14	02.222.0.014.0	Vite TCE M6X40	1	57	02.222.0.057.0	Vite	4
15	02.222.0.015.0	Cavallotto	2	58	02.222.0.058.0	Protezione	2
16	02.216.0.074.0	Motore B. & S.	1	59	02.018.0.071.0	Prigioniero	2
17	02.222.0.017.0	Vite TCCE M5	8	60	02.222.0.060.0	Cerchio	2
18	02.222.0.018.0	Manopola	1	61	02.216.0.079.0	Camera aria	2
19	02.015.0.005.0	Manettino acc.	1	62	02.216.0.078.0	Copertura	2
20	02.003.0.012.0	Dado cieco	1	63	02.151.0.025.0	Vite	8
21	02.222.0.021.0	Dado	1	64	02.078.1.055.0	Dado M10	2
22	02.222.0.022.0	Bussola	1	65	02.011.0.034.0	Rosetta	4
23	02.222.0.023.0	Leva completa	1	66	02.011.0.089.0	Vite TE M10X75	2
24	02.010.0.011.0	Dado M6	4	67	02.222.0.067.0	Supporto	1
29	02.222.0.029.0	Carrello	1	68	02.001.0.038.0	Vite TE M8X16	2
30	02.222.0.030.0	Tassello	1	69	02.002.0.018.0	Vite TE M8X25	4
31	02.222.0.031.0	Supporto leva	1	70	02.216.0.070.0	Cilindretto	1
32	02.222.0.032.0	Piastrina	1	71	02.002.0.009.0	Dado M8	4
33	02.222.0.033.0	Pulsante	1	72	02.216.0.072.1	Barra Falc.cm.81	1
34	02.222.0.034.0	Molla ritorno	1	73	02.216.0.081.0	Testina	1
35	02.222.0.035.0	Perno	1	74	02.222.0.074.0	Filo acc.	1
36	02.222.0.036.0	Filo stop	1	75	02.222.0.075.0	Dado	4
37	02.222.0.037.0	Filo frizione <i>Brematag</i>	2	76	02.222.0.076.0	Leva	1
38	02.190.0.014.0	Fascetta	2	77	02.032.1.024.0	Spinotto	2
39	02.222.0.039.0	Microinterruttore	1	78	02.222.0.078.0	Ruota Dx	1
40	02.001.0.008.0	Dado M8	8	79	02.222.0.079.0	Ruota Sx	1
41	02.003.0.016.0	Rondella	8	80	02.222.0.080.0	Leva stazionata	1
42	02.222.0.042.0	Manopola	1	81	02.079.0.016.0	Vite M10X45	2
43	02.222.0.043.0	Gommino	1	82	02.011.0.052.0	Dado autobloc. M10	2

# Tav. 223

GRUPPO TRASMISSIONE F 180

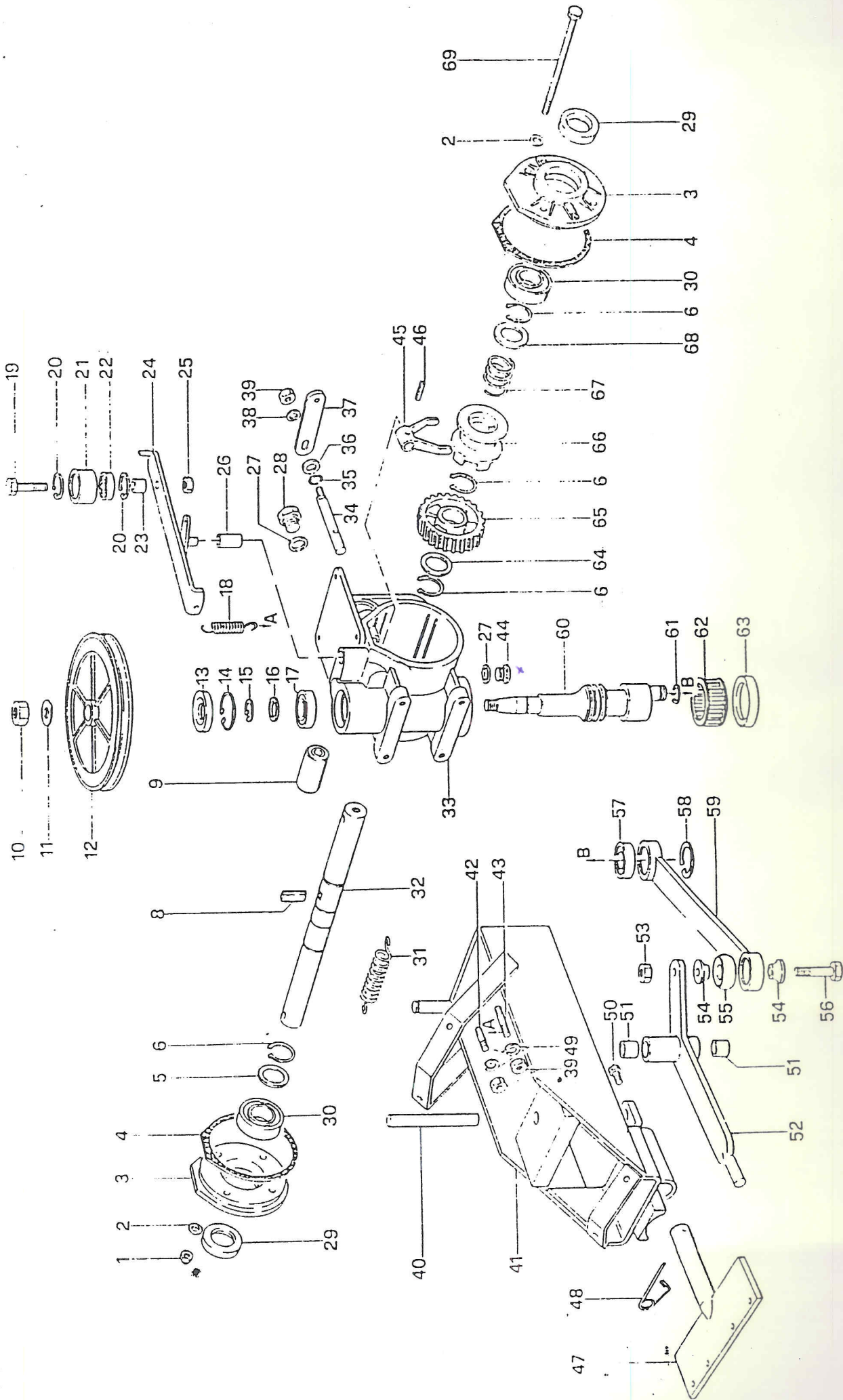

x 2  
Ölschraube

POS.	CODICE	DESCRIZIONE	Q.TA'	POS.	CODICE	DESCRIZIONE	Q.TA'
1	02.001.0.001.0	Dado M8	4	36	02.007.0.008.0	Spessore	1
2	02.001.0.002.0	Rondella	8	37	02.217.0.037.0	Levetta	1
3	02.066.0.026.0	Coperchio	2	38	02.001.0.005.0	Rosetta	1
4	02.066.0.076.0	Guarnizione	2	39	02.001.0.008.0	Dado M8	5
5	02.008.0.022.0	Spessore	1	40	02.217.0.040.0	Perno	1
6	02.007.0.010.0	Seeger E25	4	41	02.217.0.041.0	Supporto	1
8	02.217.0.008.0	Chiavetta	1	42	02.018.0.071.0	Prigioniero	3
9	02.066.0.033.0	Antivibrante	2	43	02.098.0.042.0	Prigioniero	1
10	02.011.0.061.0	Dado M14X1,5	1	44	02.009.0.020.0	Tappo olio	1
11	02.030.0.007.0	Rosetta	1	45	02.066.0.059.0	Forcella	1
12	02.217.0.012.0	Puleggia	1	46	02.017.0.092.0	Spina elastica	1
13	02.007.0.020.0	Anello tenuta	1	47	02.217.0.047.0	Supporto barra	1
14	02.007.0.045.0	Seeger I47	1	48	02.004.0.002.0	Coppiglia	1
15	02.006.0.054.0	Seeger E20	1	49	02.003.0.016.0	Rondella	2
16	02.007.0.018.0	Spessore	1	50	02.001.0.038.0	Vite TE M8x16	2
17	02.007.0.022.0	Cuscinetto	1	51	02.217.0.051.0	Boccola	2
18	02.217.0.018.0	Molla	1	52	02.217.0.052.0	Braccio	1
19	02.006.0.015.0	Vite speciale	1	53	02.001.0.052.0	Dado M 12x1,5	1
20	02.217.0.020.0	Seeger I30	2	54	02.217.0.054.0	Cono per biella	2
21	02.217.0.021.0	Bussola	1	55	02.217.0.055.0	Gommino	1
22	02.047.0.039.0	Cuscinetto	1	56	02.217.0.056.0	Vite TE M12x1,5x45	1
23	02.217.0.023.0	Distanziale	1	57	02.066.0.045.0	Cuscinetto	1
24	02.217.0.024.0	Braccio	1	58	02.001.0.058.0	Seeger I40	1
25	02.078.1.055.0	Dado M10	1	59	02.217.0.059.0	Biella	1
26	02.217.0.026.0	Boccola	1	60	02.217.0.060.0	Albero vite s/fine	1
27	02.009.0.021.0	Rondella	2	61	02.001.0.054.0	Seeger E 17	1
28	02.009.0.020.0	Tappo olio	1	62	02.217.0.062.0	Astuccio a rullini	1
29	02.066.0.029.0	Anello tenuta	2	63	02.217.0.063.0	Anello tenuta	1
30	02.001.0.009.0	Cuscinetto	2	64	02.008.0.022.0	Spessore	1
31	02.217.0.031.0	Molla	1	65	02.217.0.065.0	Corona	1
32	02.223.0.032.0	Albero porta ruote	1	66	02.217.0.066.0	Collarino	1
33	02.217.0.033.0	Corpo centrale	1	67	02.217.0.067.0	Molla	1
34	02.217.0.034.0	Asta	1	68	02.066.0.063.0	Spessore	1
35	02.066.0.047.0	Anello tenuta	1	69	02.066.0.064.0	Vite TE M8x140	1

# Tav. 218

## GRUPPO BARRA ESM CM 81

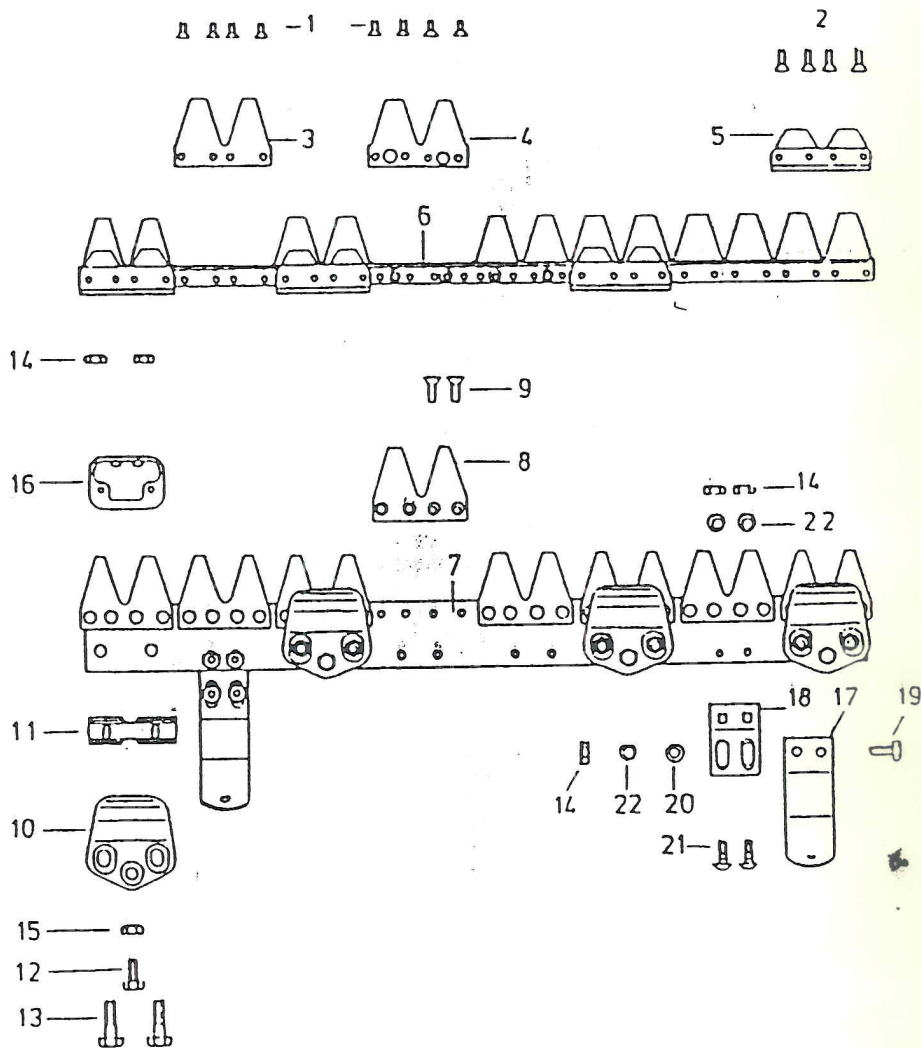

POS.	CODICE	DESCRIZIONE	POS.	CODICE	DESCRIZIONE
1	02.072.0.001.0	Ribattino	11	02.072.0.013.0	Piastrina consumo
2	02.072.0.002.0	Ribattino	12	02.218.0.012.0	Vite TE M8x30
3	02.072.0.003.0	Sezione lama doppia 4 fori	13	02.072.0.015.0	Vite TE M8x45
4	02.072.0.004.0	Sezione lama doppia 5 fori	14	02.072.0.017.0	Dado M8
5	02.084.0.007.0	Piastrina consumo	15	02.072.0.016.0	Dado VM8
6	02.218.0.006.1	Lama cm.81 <i>16 Klängen (Gummis)</i>	16	02.218.0.016.0	Slitta
7	02.216.0.072.1	Barra Falc.cm. 81	17	02.072.0.020.0	Pattino
8	02.072.0.008.0	Dente Doppio	18	02.072.0.021.0	Supporto pattino
9	02.072.0.009.0	Chiodo	19	02.084.0.015.0	Vite TE M8x25
10	02.072.0.012.0	Premilama	20	02.072.0.023.0	Rondella
			21	02.218.0.021.0	Vite
			22	02.218.0.022.0	Rondella