

Ersatzteilliste Spare Parts List

3/98

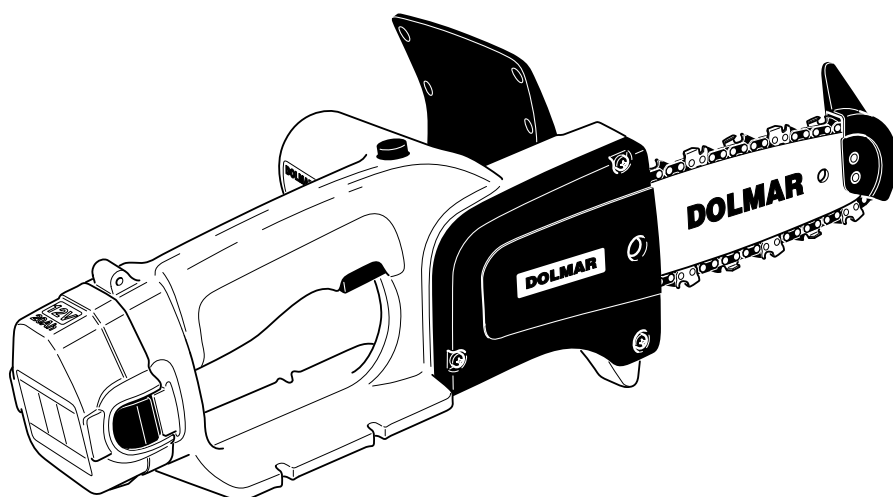

AS-1212

DOLMAR



995 700 229 (D, GB)



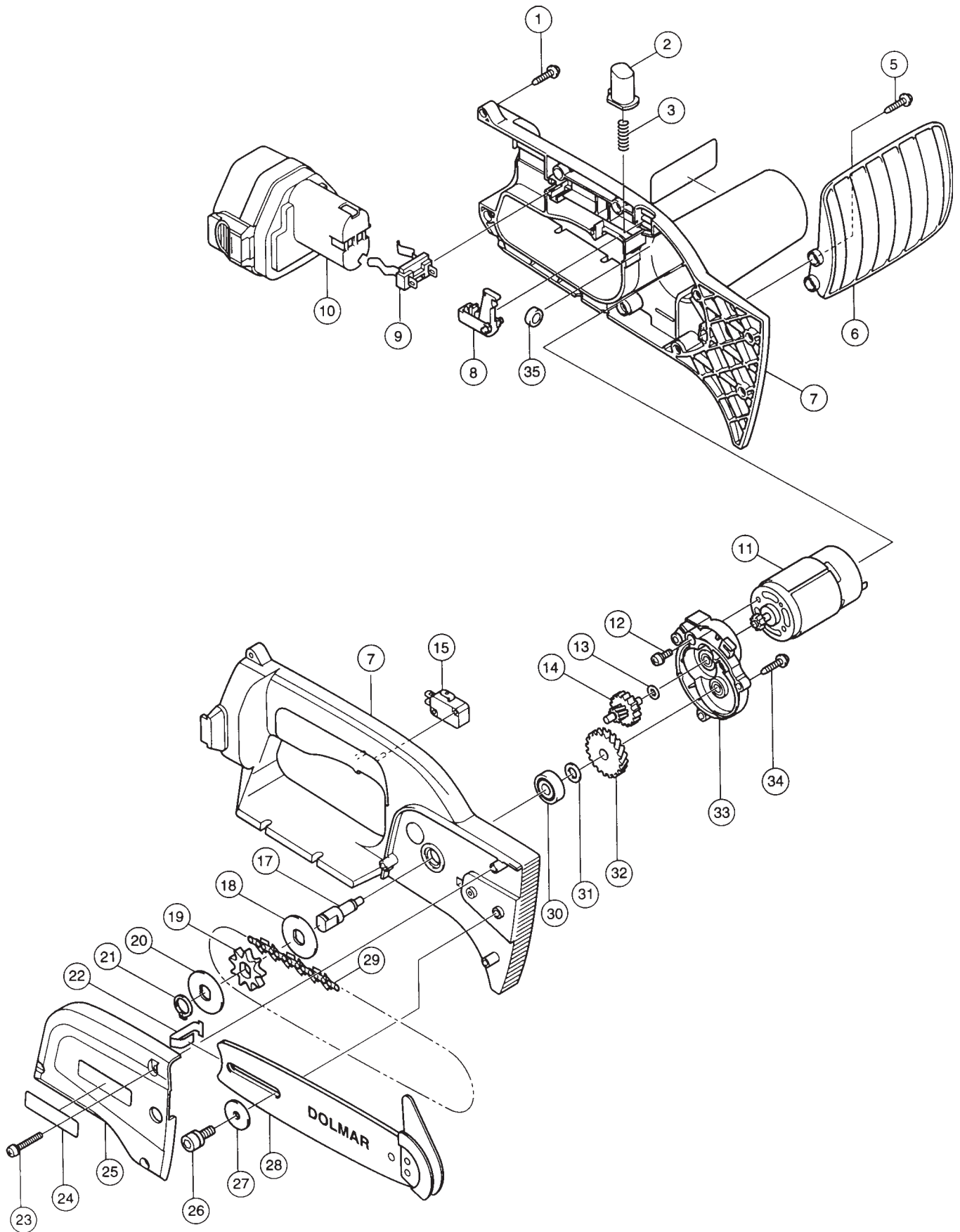



Pos.	Anz. Qty.	Teil-Nr. Part No.	Hinweise Notes	Benennung	Description
1	4	660 265 995		Blechschraube 4x18	Tapping screw
2	1	660 416 308		Schaltknopf	Lock off button
3	1	660 233 194		Druckfeder	Compression spring
5	2	660 265 995		Blechschraube 4x18	Tapping screw
6	1	660 416 312		Handschutz	Front hand guard
7	1	660 182 934		Gehäuse-Set	Housing set
8	1	660 415 679		Schalthebel	Switch lever
9	1	660 643 909		Batteriekontakt	Battery holder
10	2	660 121 200		AKKU (12 V) AP-123	Battery
11	1	660 629 715		Motor 12V	Motor
12	2	660 911 113		Schraube M4x10	Pan head screw
13	1	660 253 811		Unterlegscheibe	Flat washer
14	1	660 226 131		Stufenstirnrad Z=9/46	Gear cpl.
15	1	660 651 942		Schalter	Switch
17	1	660 322 954		Spindel	Spindle
18	1	660 267 729		Scheibe	Lock washer
19	1	660 221 504		Kettenrad Z=9	Sprocket
20	1	660 267 729		Scheibe	Lock washer
21	1	660 961 052		Sicherungsring	Retaining ring
22	1	660 232 170		Blattfeder	Leaf spring
23	3	660 911 148		Schraube M4x25	Pan head screw
24	1	660 819 087		Schild DOLMAR	Label
25	1	660 416 306		Kettenradschutz	Sprocket cover
26	1	660 922 321		Innen-6kt-Schraube M6x16	Hex. socket head bolt
27	1	660 267 173		Unterlegscheibe	Flat washer
28	1	660 012 202		Führungsschiene kpl.	Guide bar cpl.
29	1	660 020 203		Sägekette 1/4"	Saw chain
30	1	660 211 031		Kugellager 608 LLB	Ball bearing
31	1	660 253 215		Unterlegscheibe	Flat washer
32	1	660 226 478		Stirnrad Z=44	Herical gear
33	1	660 159 982		Getriebegehäuse kpl.	Gear housing cpl.
34	2	660 265 995		Blechschraube 4x18	Tapping screw
35	1	660 688 114		Funkenschutz	Line filter
•	1	660 121 201		Ladegerät LG-123	Fast charger
•	1	660 824 495		Transportkoffer	Plastic carrying case
•	1	660 414 938		Kontaktschutzkappe	Battery cover
•	1	660 416 311		Sägekettenschutz	Chain protection
•	1	980 008 210		Sägekettenöl BIOTOP 1L	Saw chain oil
•	1	953 003 090		Rundfeile ø 4 mm	Round file
•	1	953 004 010		Feilenheft	File handle
•	1	940 805 000		6kt-Stiftschlüssel 5 mm	Allen key
				Zubehör (nicht im Lieferumfang)	Accessories (not incl. in delivery)
•	1	660 121 300		Teleskoprohr TR-220	Telescopic pipe



	Zeichenerklärung	Key to symbols	Légende
<p>⇒ 1999999 2000000 ⇒ 4/95 ⇒ SI 5/95 => xxx = { m* ⊗ Corr.</p>	<p>Produktion bis Serien-Nr. Neues Teil ab Serien-Nr. Neues Teil ab Monat / Jahr Siehe Service-Information Monat / Jahr Teil gleichwertig ersetzt Nicht mehr lieferbar Keine Serienausführung, jedoch verwendbar Beinhaltet Positions-Nr. Meterware Innensternschraube Druckfehlerberichtigung</p>	<p>Production to serial number New part from serial number New part from Month / Year See Service-Information Month / Year Modified part No more available No standard execution, may be used Contains item no. Sold by the meter Star socket screw Error correction</p>	<p>Production jusqu'à n° de série Nouveau pièce à partir du n° de série Nouveau pièce à partir de Mois / Année Voir Service-Information Mois / Année Pièce modifiée Plus livrable Aucune exécut. en série, cependant utilisable contient n° de numéro Au mètre Vis à étoile intérieure Rectification d'erreurs</p>
	Explicación de símbolos	Verklaring der tekens	Chiarificazione dei simboli
<p>⇒ 1999999 2000000 ⇒ 4/95 ⇒ SI 5/95 => xxx = { m* ⊗ Corr.</p>	<p>Producción hasta N° de serie Pieza nueva a partir de N° de serie Pieza nueva a partir de mes / año Véase inform. servicio mes / año Pieza modificada Agotado No es de serie, pero sirve Contiene pos N° Por metro Tornillo estrella interior Fe de erratas</p>	<p>In productie tot serie-Nr. Nieuw onderdeel vanaf serie-Nr. Nieuw onderdeel vanaf maand / jaar Zie service-informatie maand / jaar Vervangen door gelijkwaardig onderdeel Niet meer leverbaar Geen serieuitvoering, maar wel bruikbaar Omvat Positie-Nr. Mergoed Binnen-ster schroef Drukfoutcorrectie</p>	<p>Produzione fino al n. di serie Nuovo pezzo a partire dal n. di serie Nuovo pezzo a partire dal mese / anno Vedere il servizio inform. del mese / anno Pezzo sostituito con un pezzo equivalente Non più disponibile Non è un modello di serie, ma ugualm. utilizza. Comprende la posizione n. Articoli a metraggio Vite con intaglio a stella Rettifica di errori di stampa</p>
	Tegnforklaring	Teckenförklaring	Merkklen selvitys
<p>⇒ 1999999 2000000 ⇒ 4/95 ⇒ SI 5/95 => xxx = { m* ⊗ Corr.</p>	<p>Produktion indtil løbenr. Ny del fra og med løbenr. Ny del fra og med måned / år Se Service-Information måned / år Afløst med tilsvarende del Kan ikke leveres mere Ikke standardudgave, men kan anvendes Inkluderer position nr. Metervare Skruer med indiv. stjerne Rettelse af trykfejl</p>	<p>Produktion t o m serienr Ny detalj fr o m serienr Ny detalj fr o m måned / år Se serviceinformation måned / år Ersatt med motsvarande detalj Kan ej mera levereras Ej serieutförande, men användbar Innehåller positionsnr Metervara Skruv med stjärnspår Korrigerig av tryckfel</p>	<p>Tuotanto sarjanumeroon ... asti Uusi osa alkaen sarjanumerosta Uusi osa alkaen kuukausi / vuosi Katso huolto-ohje kuukausi / vuosi Osa vaihdettu vastaavaan Ei enää toimitettavissa Ei sarjavalmistusta, voidaan kuitenkin käyttää Positionumero sisältyy Metritavara Tähtikoloruuvi Painovirheen oikaisu</p>