

AKKU-BOHRMASCHINE

CD12CB----C

TYPE 3

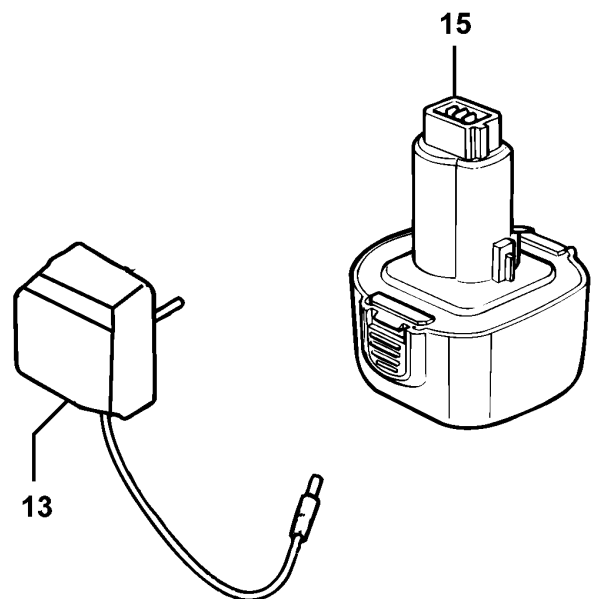
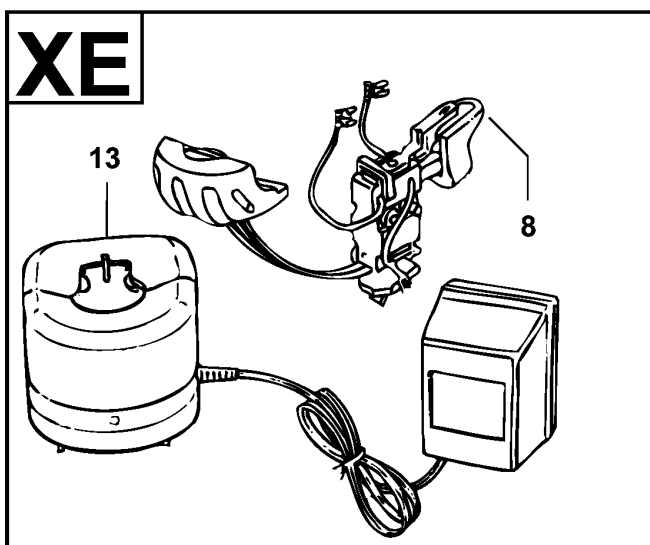
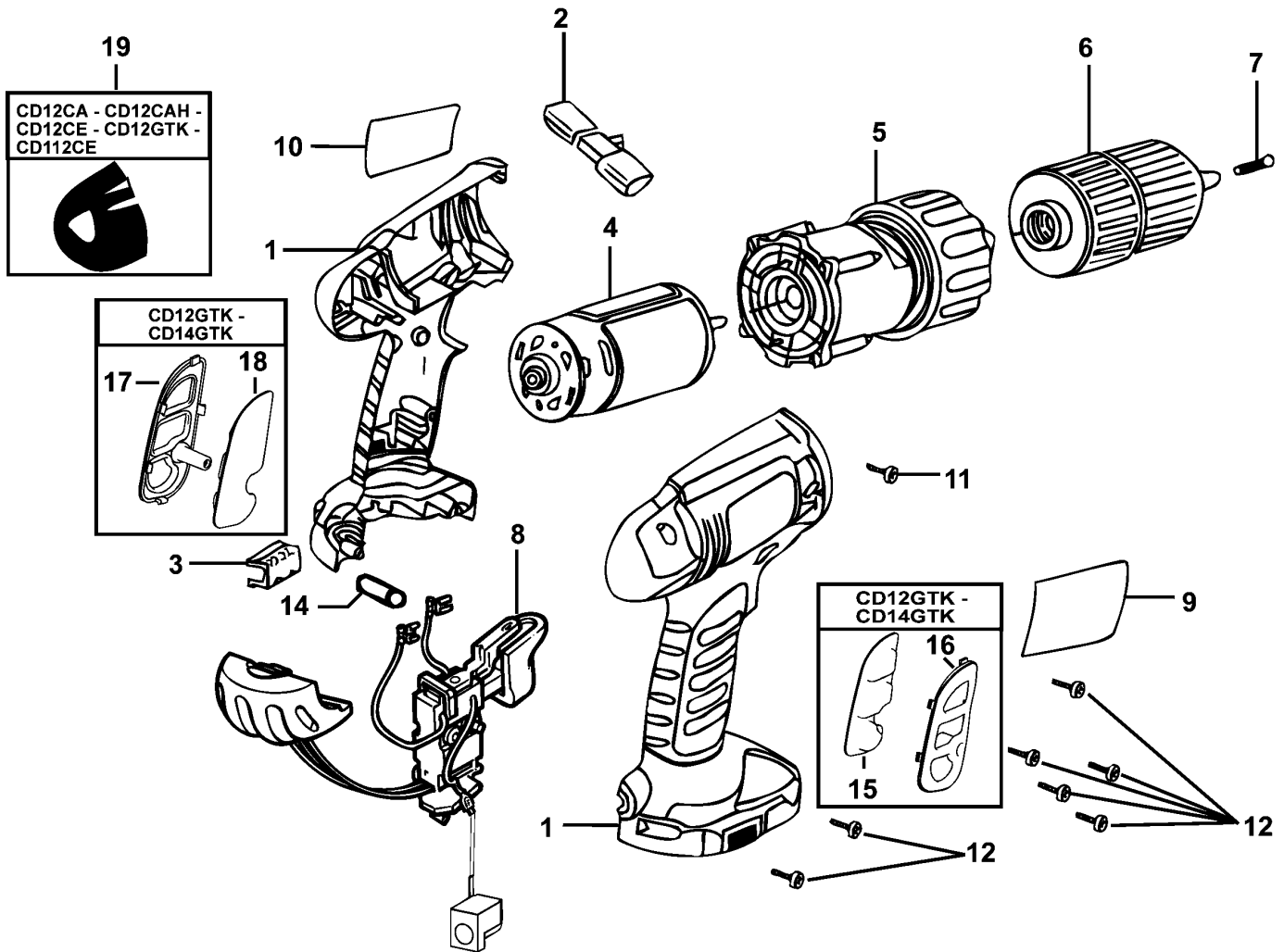

AKKU-BOHRMASCHINE

CD12CB----C

TYPE 3



Pos. Nr	Ersatzteilnummer	Beschreibung	Preis	Variants
1	1	5102540-02	GEHAEUSEPAAR	
2	1	311978-01	ANTRIEB	
3	1	148354-03	HALTER	
4	1	5102761-00	MOTOR + ZW.GETR.	
5	1	5100850-10	GETRIEBE ZSB	GB
5	1	5100850-10	GETRIEBE ZSB	QW
5	1	5148192-00	GETRIEBE ZSB	XE
6	1	5147554-00	SPANNBOHRFUTTER	XE
6	1	419233-05	SPANNBOHRFUTTER	GB
6	1	419233-05	SPANNBOHRFUTTER	QW
7	1	149518-01	SCHRAUBE	
8	1	5102550-04	SCHALTER ZSB	
9	1	5102538-00	AUFKLEBER	GB
9	1	5102538-00	AUFKLEBER	QW
9	1	5102538-10	AUFKLEBER	XE
10	1	5102537-00	TYPENSCHILD	
11	1	498511-00	SCHRAUBE	
12	7	311993-00	SCHRAUBE	
13	1	418339-02	LADEGERAET (EURO)	QW
13	1	418338-02	LADEGERAET	GB
13	1	763840-02	LADEGERAET ZSB	XE
19	1	5103587-03	KAPPE ZSB	QW
19	1	5103587-03	KAPPE ZSB	GB