

5 HP 26" TILLER - - MODEL NUMBER XF550B BELT GUARD AND PULLEY ASSEMBLY

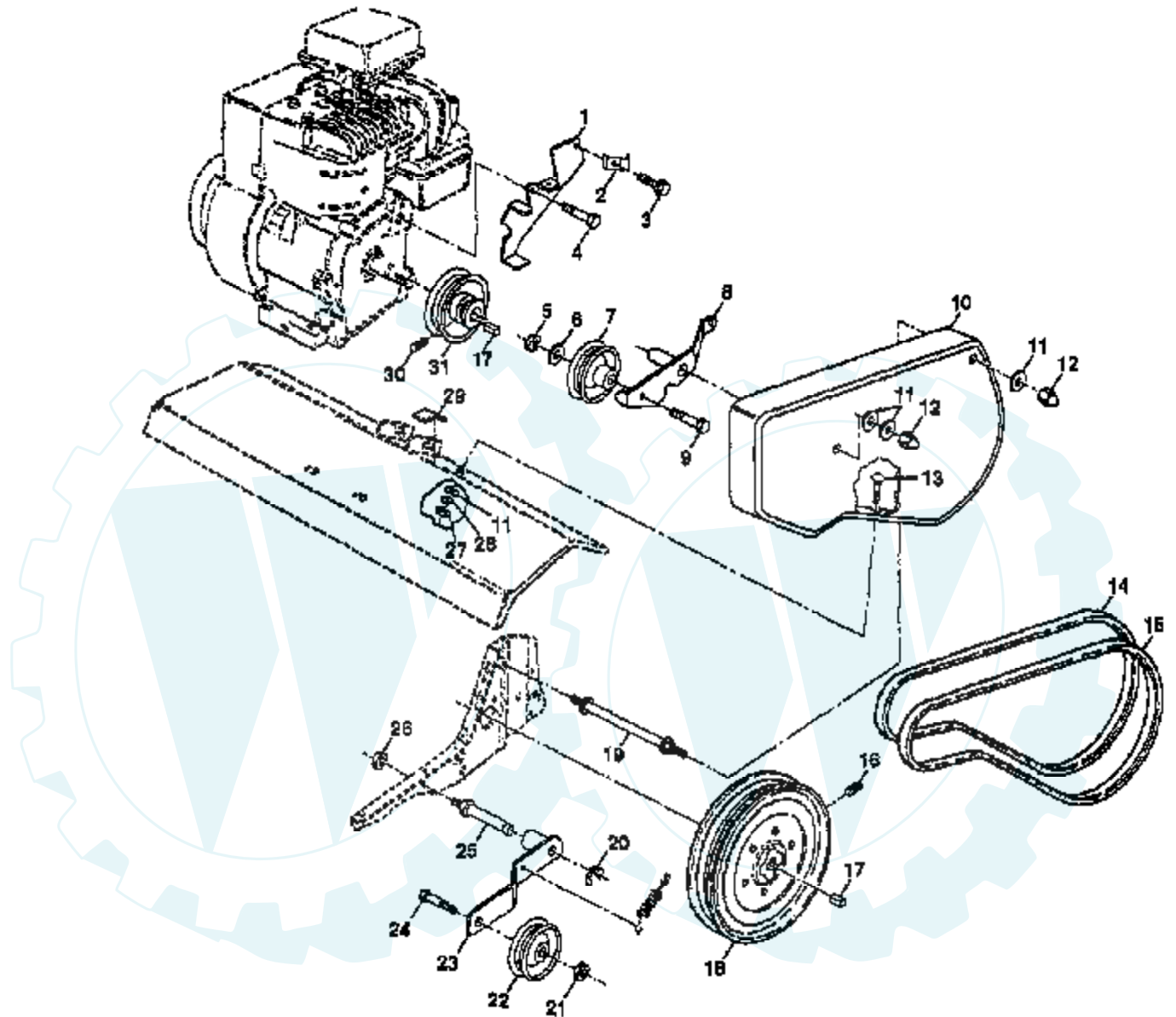

***STANDARD HARDWARE — PURCHASE LOCALLY**

NOTE: All component dimensions given in U.S. inches.
1 inch = 25.4 mm

Ref #	Part Number	Qty	Description
1	123643X		SUB= 159268
2	9484R		CONDIUT CLIP T
3	86777		SUB= 750097
4	74770812		SCREW
5	73220600		NUT.HEX.3/8-16UNC
6	19131316		WASHER
7	2009J		PULLEY W/SPACER
8	127180X		ARM.ASM.REV.IDLER
9	74760624		SUB= 74930624
10	106970X475		"GRD,BELT"
11	19091016		WASHER
12	104213X		NUT-CAP TI
13	72140405		BOLT T
14	133035		BELT-V
15	2614J		SUB= TH3H440
16	23230506		SET SCREW
17	2649M		KEY T
18	2607J		SHEAVE TI
19	110550X		BOLT TI
20	12000036		KLIP RING TI
21	73350600		NUT
22	9178R		SUB= 75673
23	674A30		IDLER ARM TI
24	74760620		SUB= 74780620
25	106968X		SHAFT IDLER TI
26	73350500		JAM NUT TI
27	73220400		SUB= 50675
28	10040400		LOCKWASHER
29	109227X		PAD IDLER TI
30	23200404		SET SCREW
31	101189L		ENGINE PULLEY TI
	127700		DECAL, LOGO

Ref #	Part Number	Qty	Description
1	131268X475		HANDLE BRKT
2	72140512		BOLT
3	9266R		SUB= 624A78
4	2623J		SUB= 2623J500
5	73680500		SUB= 73690500
6	19111116		WASHER
7	19121414		WASHER
8	63688		SUB= 136376
9	471J		BOLT CT
10	10040500		LOCKWASHER
11	73220500		NUT.HEX.5/16-18
12	98000129		NUT
13	72140506		BOLT
14	674A150475		"PANEL,HDLE"
15	72110510		BOLT
16	2624J		SUB= 2624J500
17	106932X		KNOB T(3/8 HOLE)
18	3066J		CABLE CLUTCH T
19	2635J		CONTROL LEVER TI
20	23200405		SCREW
21	12000027		E-RING
22	101248K		ROD REVERSE TI
23	1778E		RIVET.RD.HD.DRILL
24	2613J		REVERSE ROD TI
25	19131316		WASHER
26	76020412		COTTER PIN
27	76020308		SUB= 3145
	121753X		DECAL REVERSE
	127699		DECAL, HP
	110614X		DECAL TI
	127698		DECAL, LOGO
	133537		MANUAL

5 HP 26" TILLER - - MODEL NUMBER XF550B

TINE ASSEMBLY

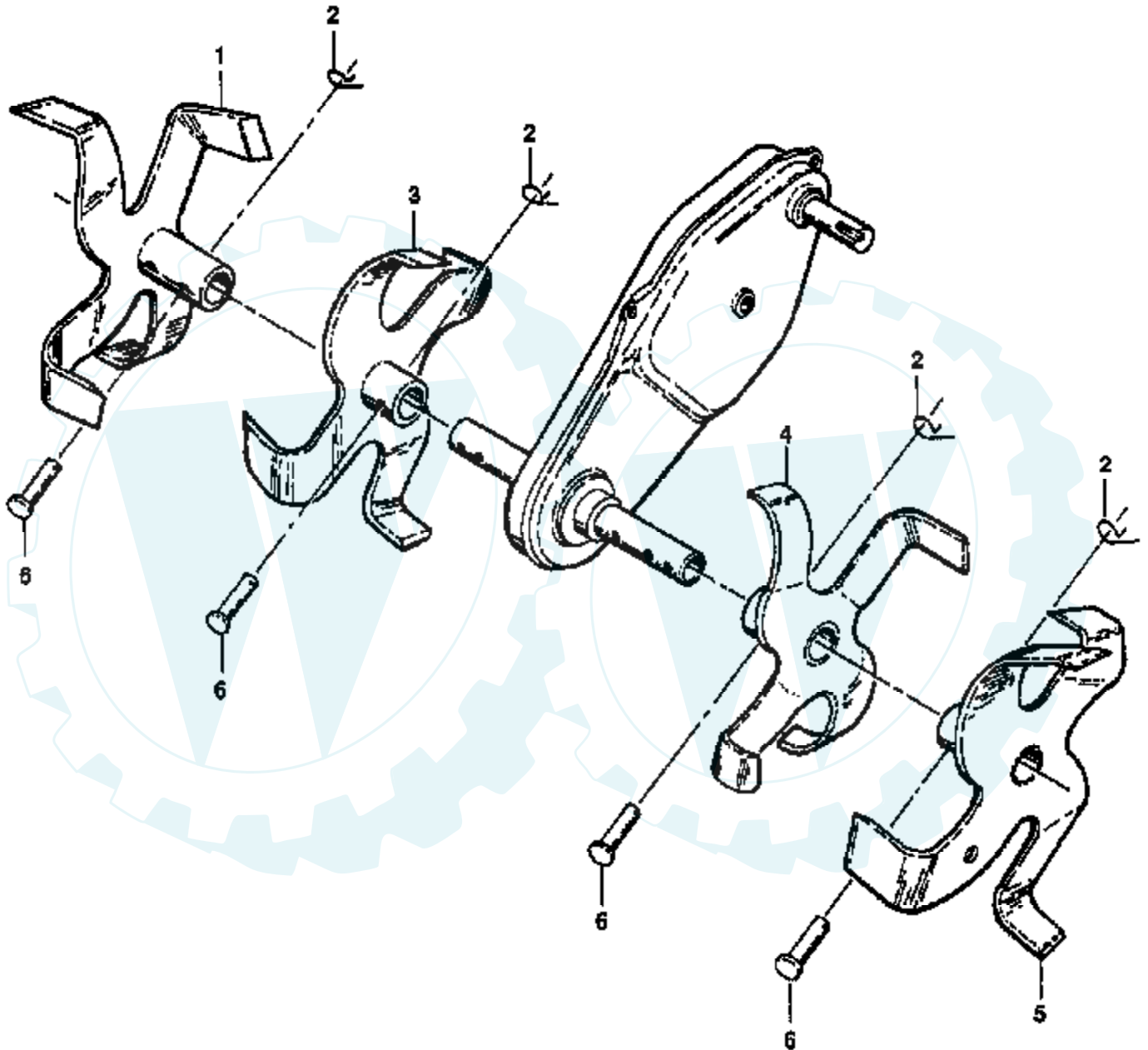

Ref #	Part Number	Qty	Description
1	100746M		TINE WELDMENT TI
2	3146R		RETAINER.SPRING
3	674A43		TINE TI
4	674A42		TINE TI
5	100744M		TINE WELDMENT TI
6	4929H		RIVET.PAN HD.1.75



5 HP 26" TILLER - - MODEL NUMBER XF550B

TRANSMISSION

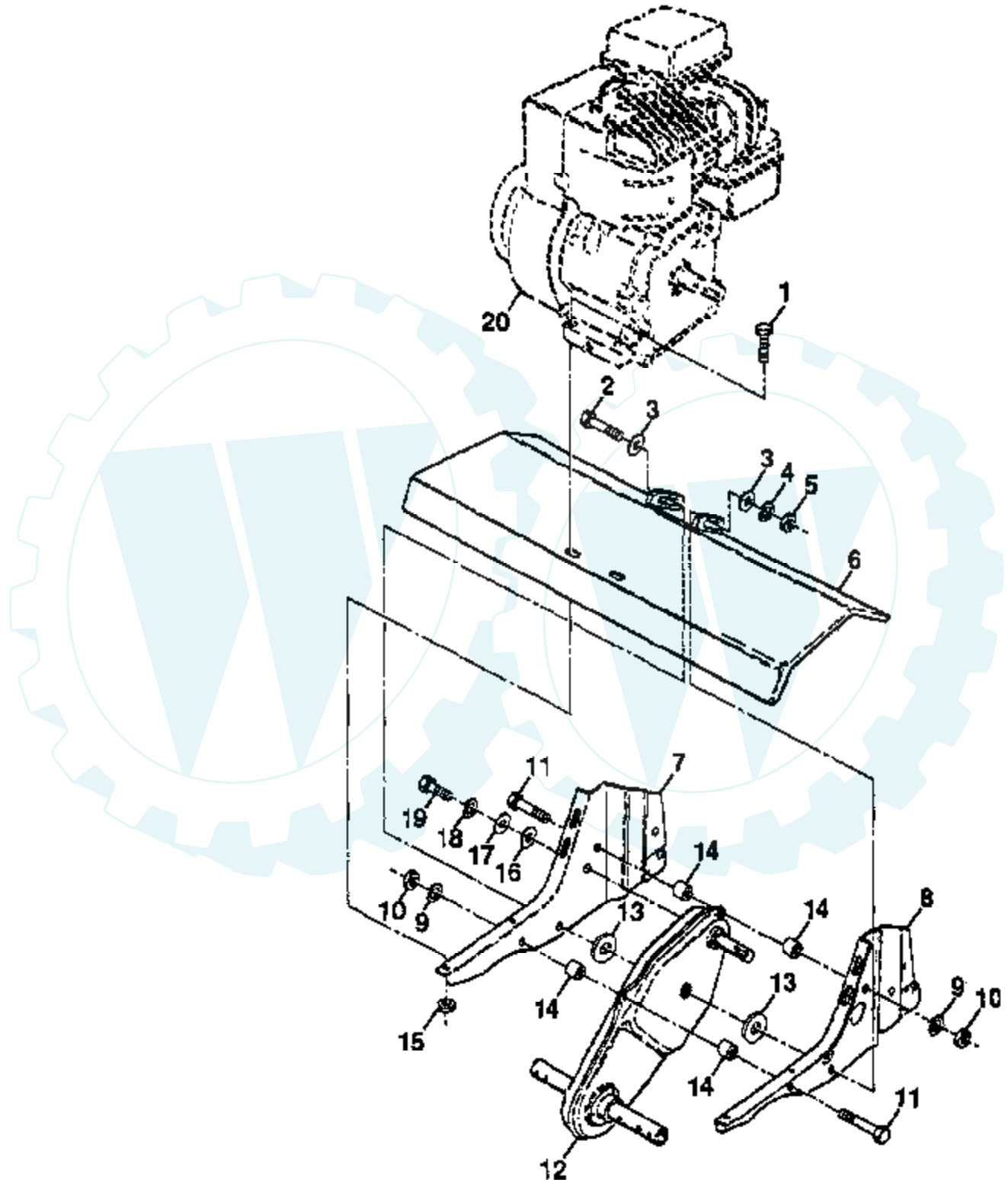

*STANDARD HARDWARE — PURCHASE LOCALLY

NOTE: All component dimensions given in U.S. inches.

1 inch = 25.4 mm

[Der Ersatzteilspezialist im Internet.](#)

Ref #	Part Number	Qty	Description
1	74760524		BOLT.HEX.5/16-1.5
2	74610652		BOLT.3/8-24X3.75
3	19131311		WASHER
4	10040600		LOCKWASHER
5	7810H		GRIPCO NUT
6	9057R475		"SHIELD,TINE "
7	1949J		SUB= 1949J500
8	110519X		BRACKET.ENG.LH.
9	10040500		LOCKWASHER
10	73220500		NUT.HEX.5/16-18
11	74760544		SUB= 74780544
12	126669X		SUB= 532126669
13	19171616		WASHER
14	9173R		SPLIT SPACER RT
15	73510500		NUT
16	19091412		WASHER
17	19092016		WASHER
18	10040400		LOCKWASHER
19	74610412		BOLT
20	130202		NLA
	110612X		DECAL TI
	120076X		SUB= 120075X
	121543X		SUB= 271948

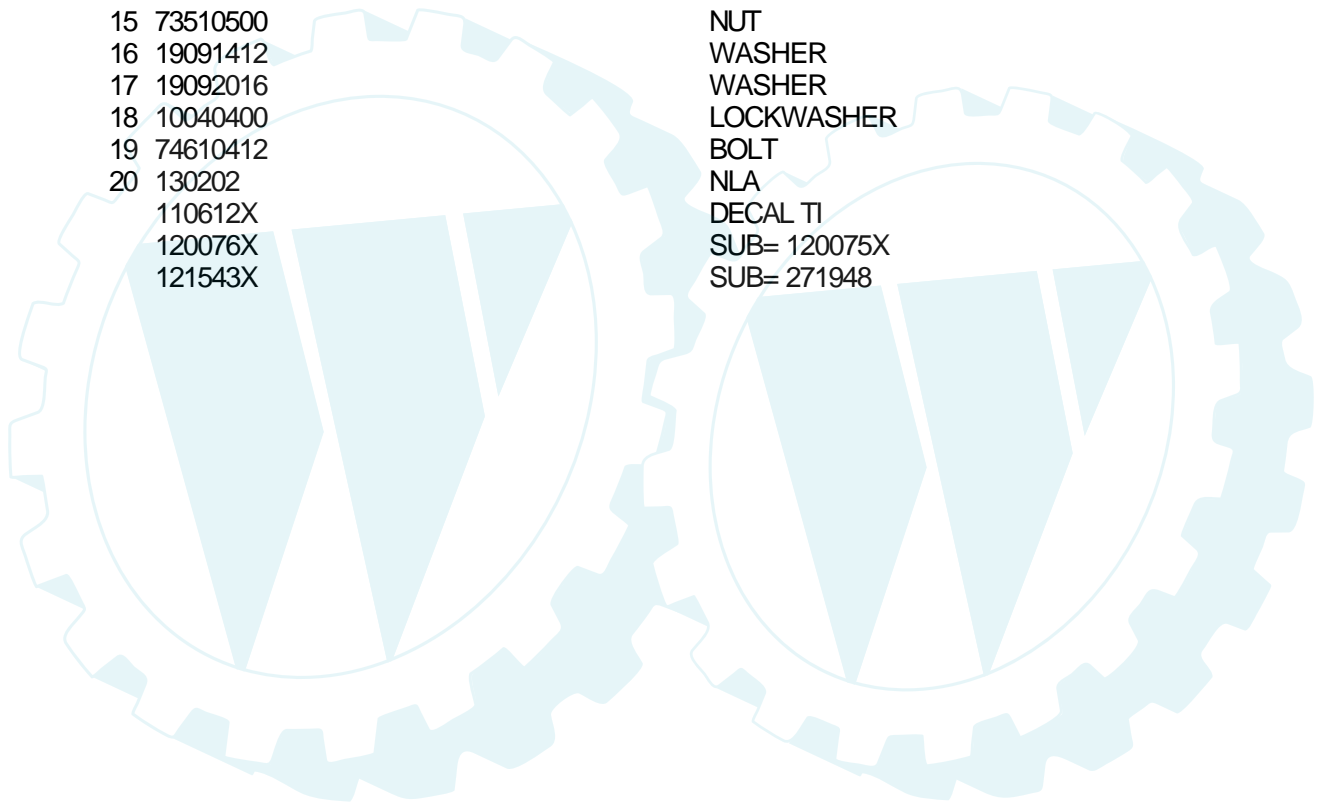

5 HP 26" TILLER - - MODEL NUMBER XF550B
WHEEL AND DEPTH STAKE ASSEMBLY

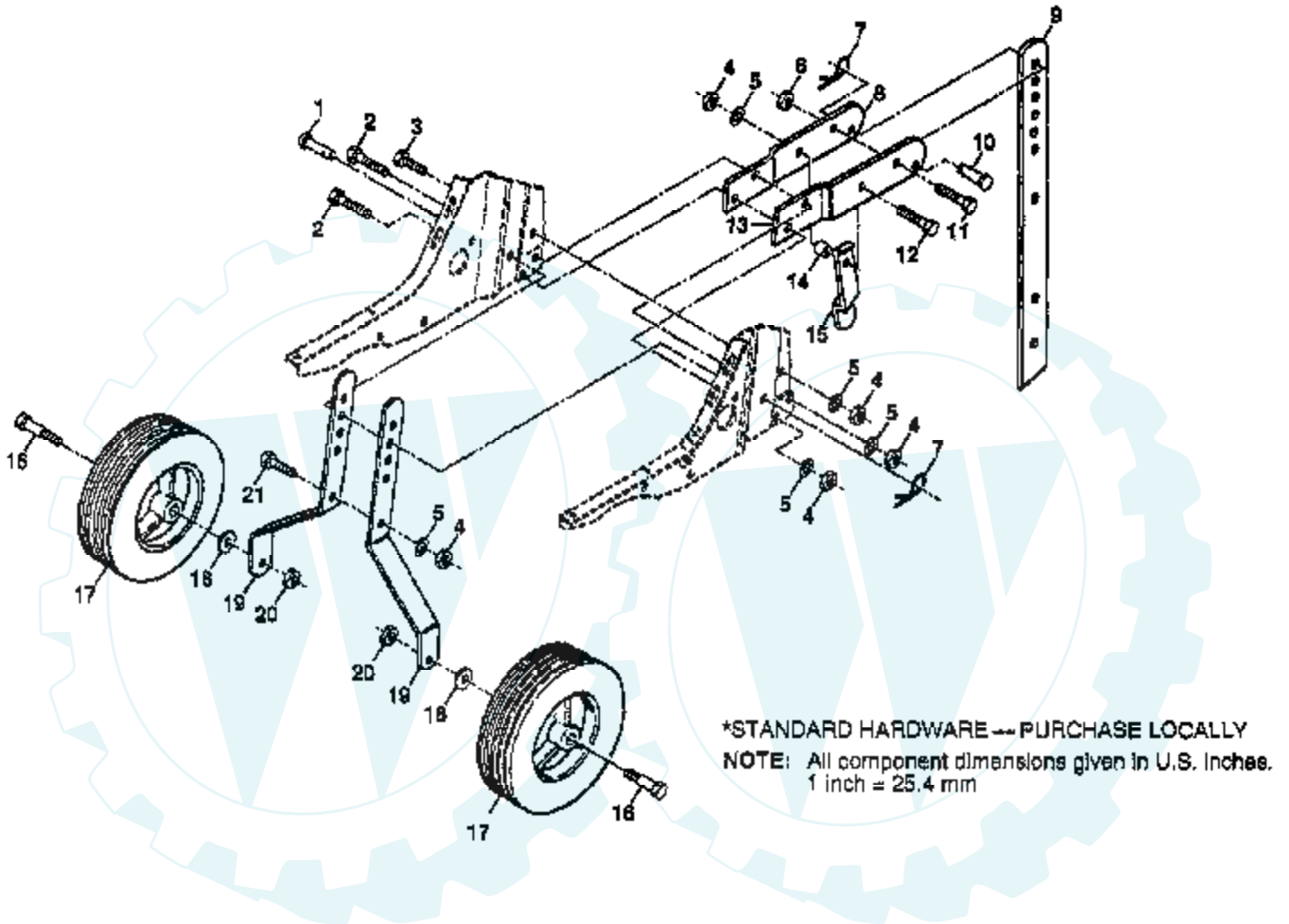

Ref #	Part Number	Qty	Description
1	9194R		DRILLED RIVET RT
2	74760520		BOLT
3	74760512		BOLT
4	73220500		NUT.HEX.5/16-18
5	10040500		LOCKWASHER
6	7810H		GRIPCO NUT
7	4921H		SPRING.RETAINER
8	1952J		SUB= 1952J500
9	122233X		SUB= 2582J
10	326J		SUB= 4929H
11	74610624		BOLT.3/8-24X1-1/2
12	74760524		BOLT.HEX.5/16-1.5
13	1951J		SUB= 1951J500
14	120958X		WASHER
15	5388J		STAKE SPRING TI
16	121117X		BOLT SHOULDER
17	9188R		SUB= 107644X
18	19131311		WASHER
19	9190R		SUB= 9190R500
20	73680600		SUB= 73690600
21	74760516		SUB= 77394

