

TILLER - - MODEL NUMBER TS821C

DECALS

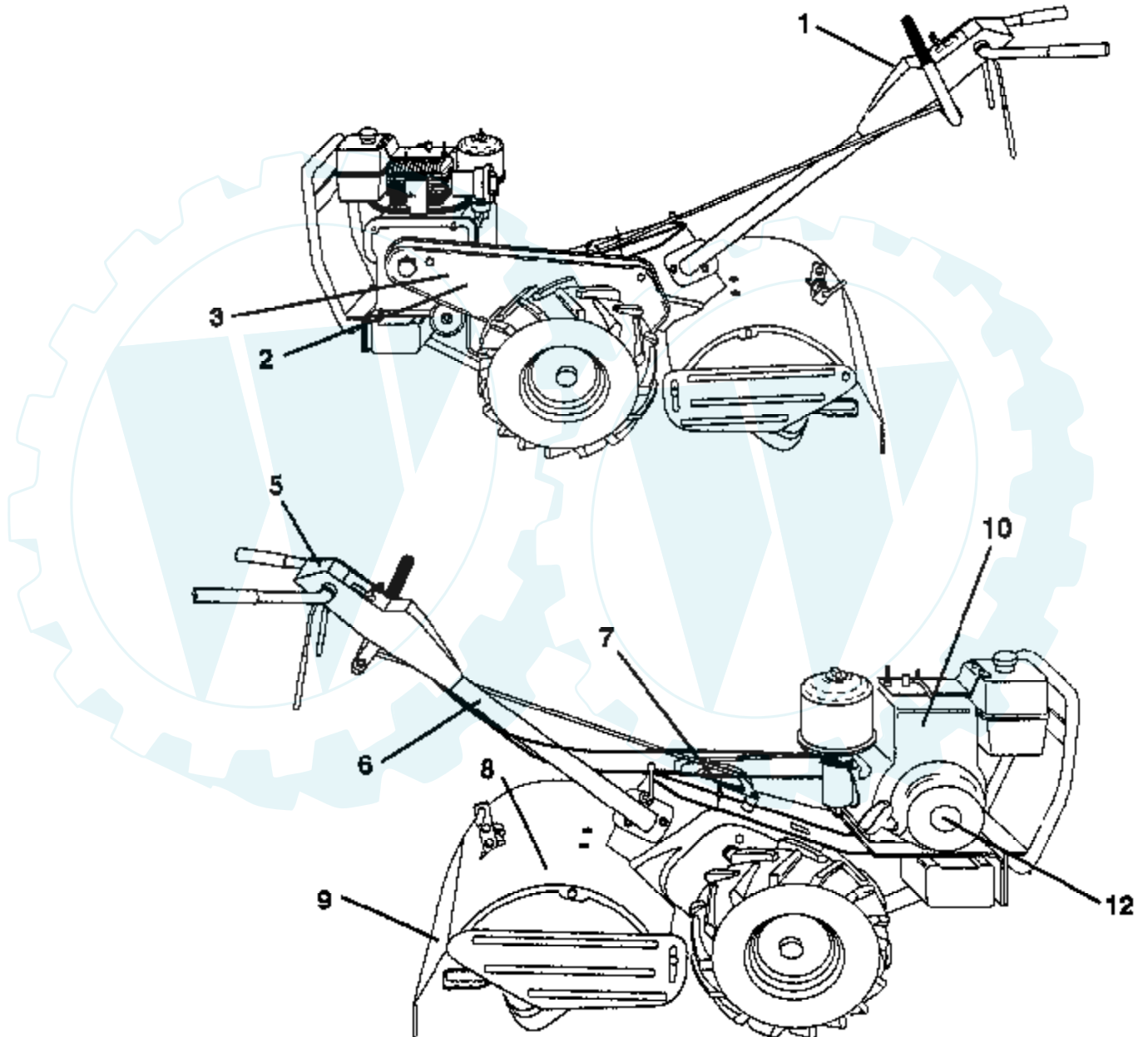

Ref #	Part Number	Qty	Description
1	143107		DECAL.PNL.CTRL.
2	143097		NAMEPLATE.HUSKEE
3	143105		DECAL.GUARD.BELT
5	139384		DECAL.INST.PNL.CT
6	120431X		DECAL TI
7	138546		DECAL.SHIFT.IND.
8	110593X		SUB= 121858X
9	120075X		DECAL TI
10	143103		DECAL.ENG.B&S.8HP
12	143104		DECAL.ENG.B&S.8HP
	152789		MANUAL.O.TS821C.E



TILLER - - MODEL NUMBER TS821C

HANDLE ASSEMBLY

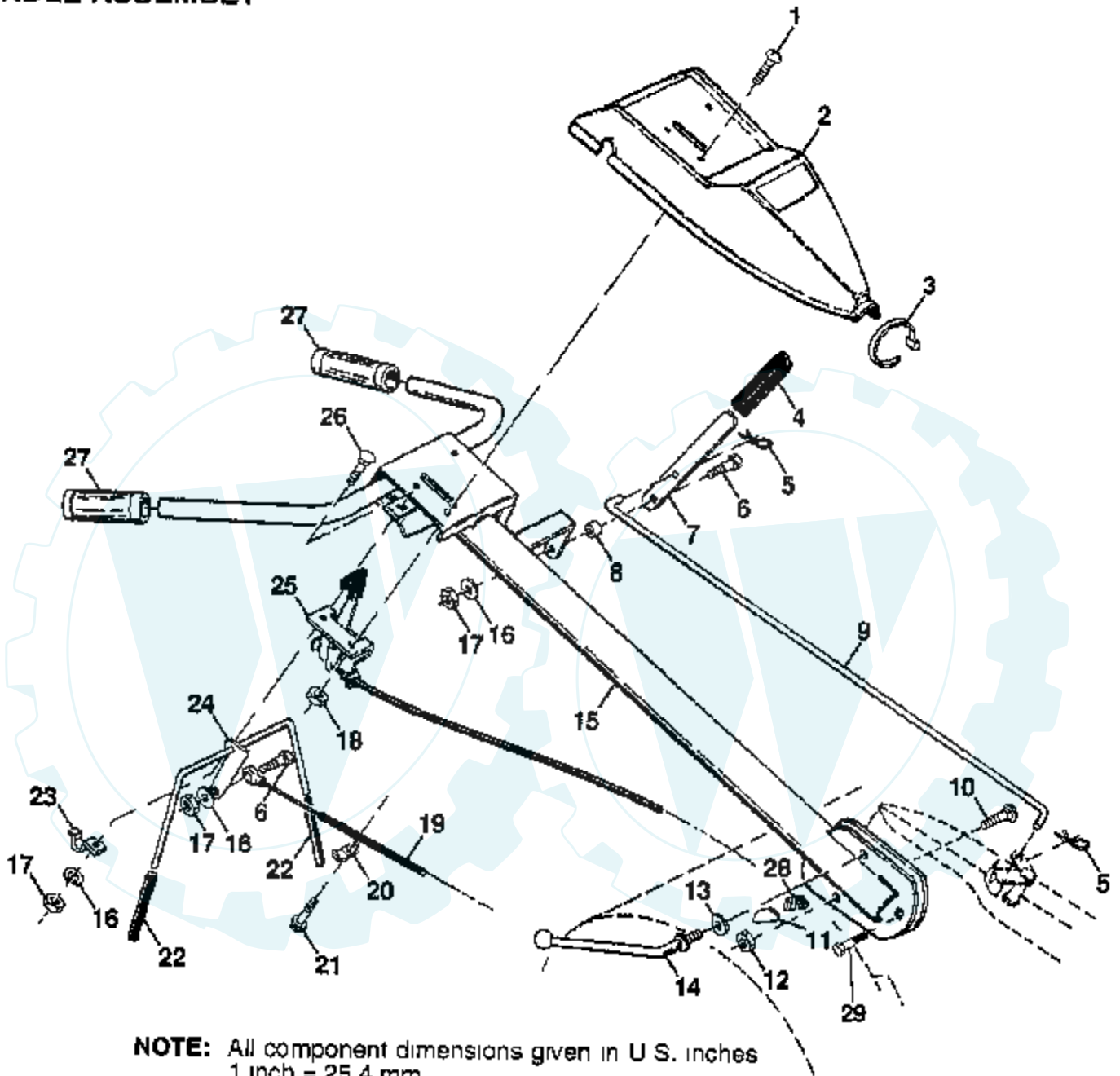

Ref #	Part Number	Qty	Description
1	71191008		SCREW.PNHD.10-24
2	126951X		"PANEL,CONT TI"
3	104164X		TIE CABLE CRT
4	8206H		GRIP T
5	4497H		RETAINER M
6	81328		SHOULDER BOLT ST
7	109335X		SHIFT HANDLE CRT
8	109313X		GROMMET CRT
9	138400		ROD.SHIFT
10	72110608		BOLT D
11	109229X		LOCK CRT
12	73930600		LOCKNUT
13	19131611		WASHER CRT
14	109228X		LEVER LOCK CRT
15	150256X505		SUB= 150256X431
16	10040400		LOCKWASHER
17	73220400		SUB= 50675
18	73731000		NUT
19	101251L		CABLE-CLUTCH CRT
20	9484R		CONDIUT CLIP T
21	86777		SUB= 750097
22	102604X		GRIP BAR CRT
23	102744X		SUB= 102744X431
24	105216X		"ASSY CONTROL, BAR"
25	138305		CONTROL.THROTTLE
26	72140404		BOLT
27	9266R		SUB= 624A78
28	138283		LOCK.HANDLE
29	150696		BOLT PIVOT

TILLER - - MODEL NUMBER TS821C

MAINFRAME, LEFT SIDE

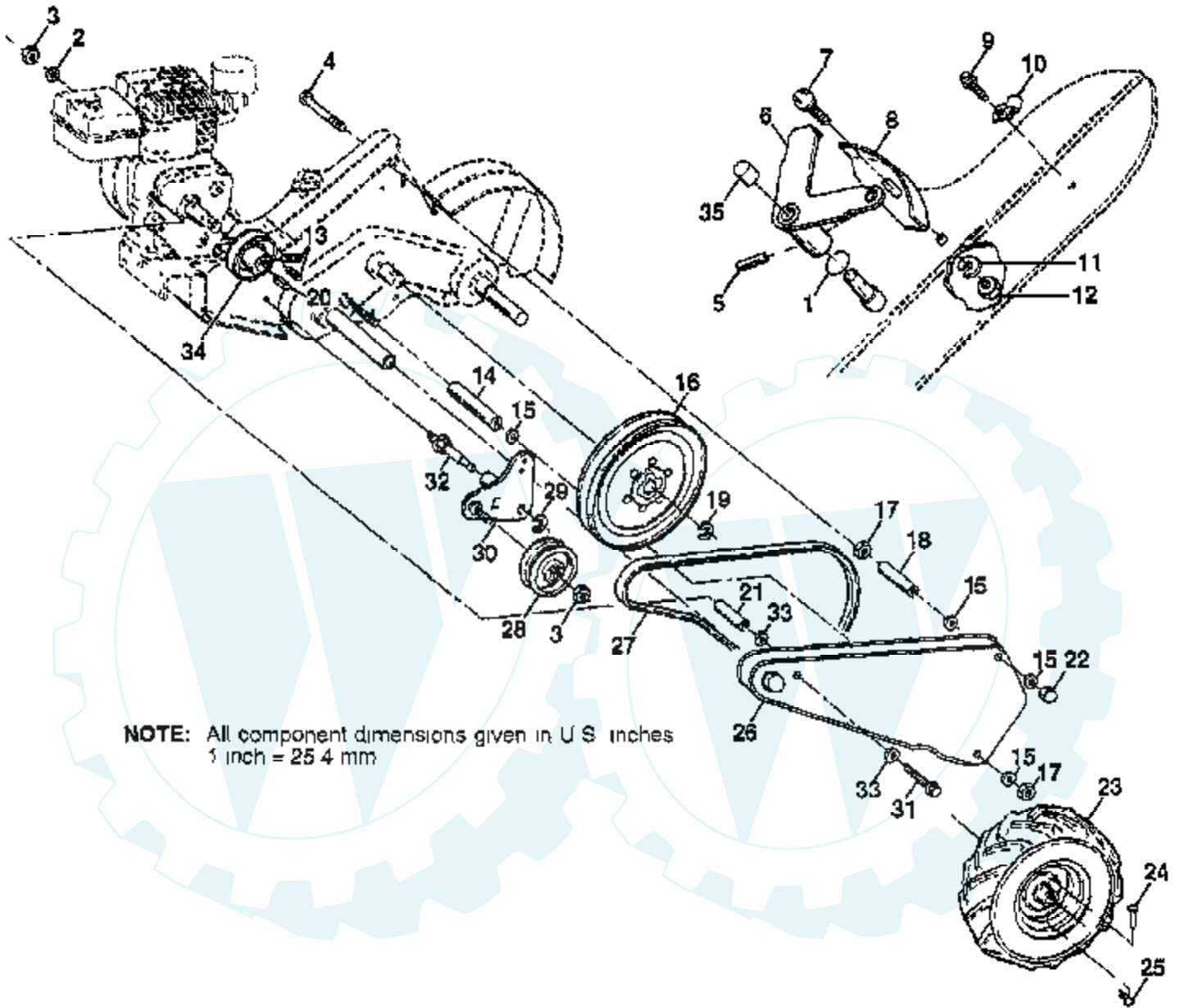

Ref #	Part Number	Qty	Description
1	106160X		O-RING TI
2	10040600		LOCKWASHER
3	73220600		NUT.HEX.3/8-16UNC
4	74930572		BOLT TI
5	1572H		SUB= 2882J
6	110111X		LEVER ASM CRT
7	72110404		BOLT
8	8700J		PANEL TI
9	86777		SUB= 750097
10	9484R		CONDIUT CLIP T
11	10040400		LOCKWASHER
12	73220400		SUB= 50675
13	23230506		SET SCREW
14	8382J		SPACER TI
15	19111116		WASHER
16	145102		SHEAVE.TRANS.
17	73220500		NUT.HEX.5/16-18
18	8381J		SPACER TI
19	12000028		SUB= 2267J
20	4914H		KEY TI
21	139155		SPACER.SPLIT
22	104214X		NUT TI
23	5015J		TIRE TI
	5014J		WHEEL TI
	795R		SUB= 65139
24	4929H		RIVET.PAN HD.1.75
25	4921H		SPRING.RETAINER
26	102818X505		GUARD BELT RED
27	138399		BELT.DRIVE
28	104680X		SUB= 4371J
29	12000032		KLIP RING
30	105611X		SUB= 918105611X
31	74770844		BOLT1/2-20UNF2.75
32	139401		SHAFT.IDLER
33	19171616		WASHER
34	4368J		SHEAVE CRT
35	140062		CAP PLUNGER BLACK

TILLER - - MODEL NUMBER TS821C MAINFRAME, RIGHT SIDE

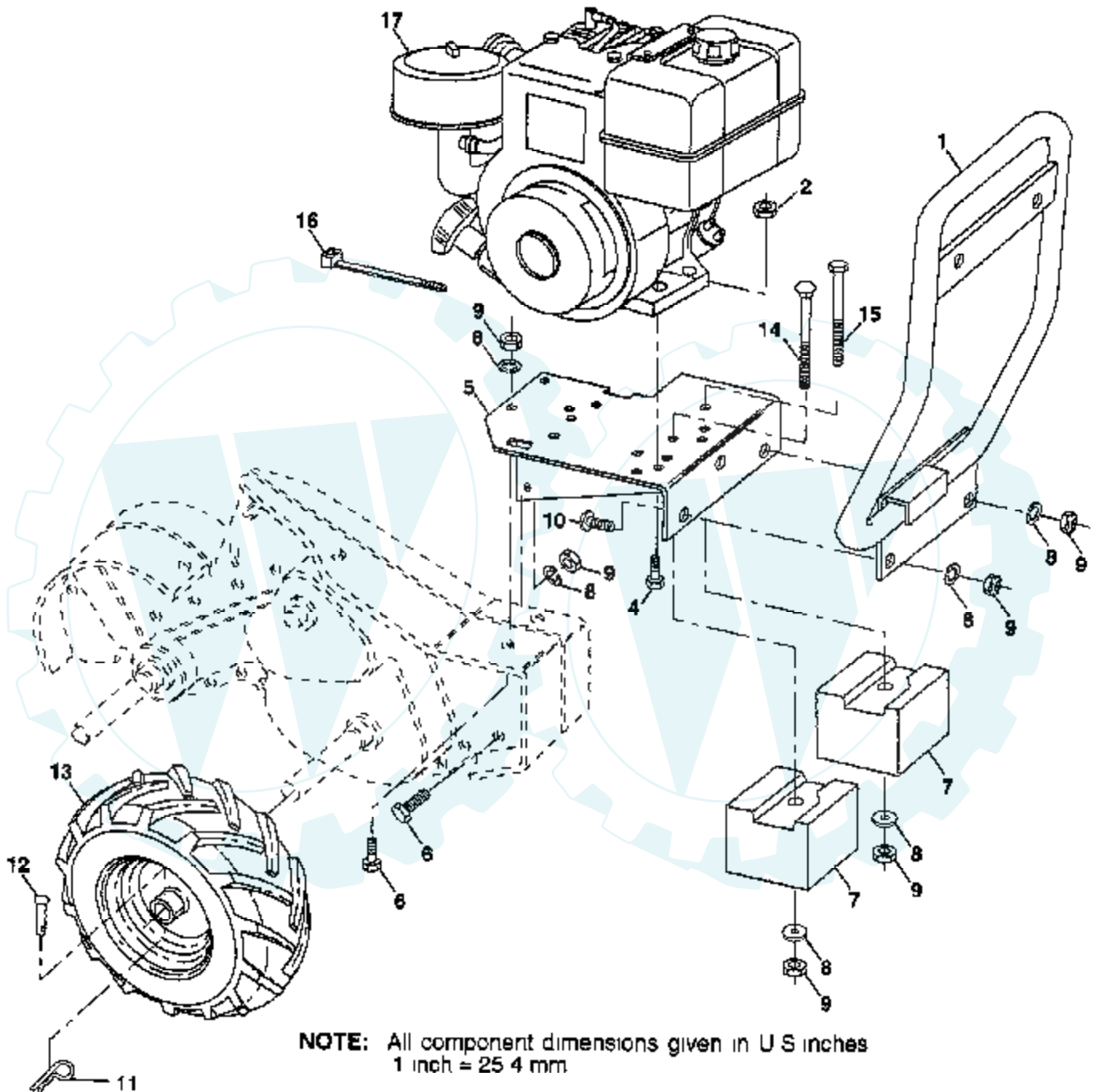

Ref #	Part Number	Qty	Description
1	138402		BUMPER.ASM
2	73510500		NUT
4	74760528		BOLT
5	138669		"ASM. ENGINE, BASE"
6	74760616		BOLT
7	8450J		COUNTERWEIGHT CRT
8	10040600		LOCKWASHER
9	73220600		NUT.HEX.3/8-16UNC
10	72140608		SUB= 72110608
11	4921H		SPRING.RETAINER
12	4929H		RIVET.PAN HD.1.75
13	5015J		TIRE TI
	5014J		WHEEL TI
	795R		SUB= 65139
14	72470636		BOLT CRT
15	7760672		BOLT, HEX HEAD
16	104164X		TIE CABLE CRT
17			REFER TO IMAGE

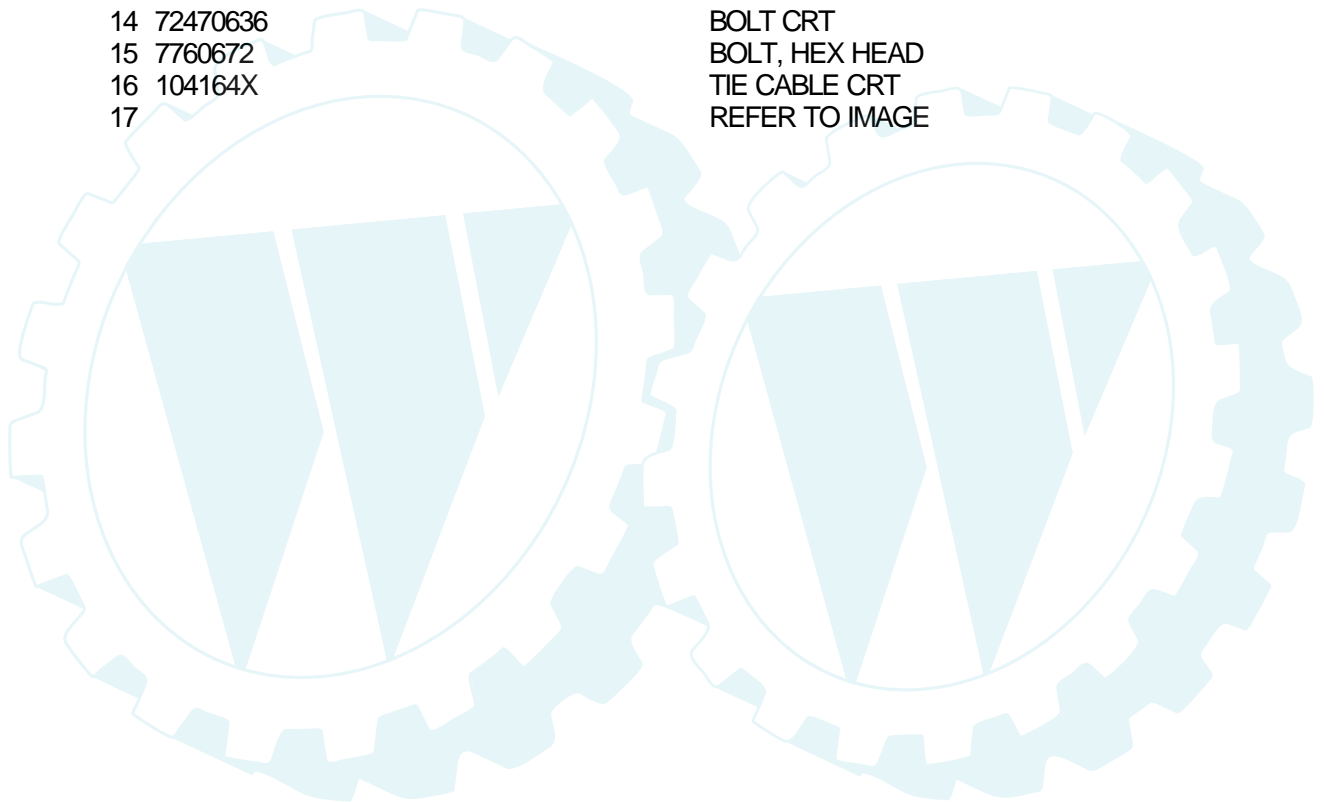

TILLER -- MODEL NUMBER TS821C

TINE ASSEMBLY

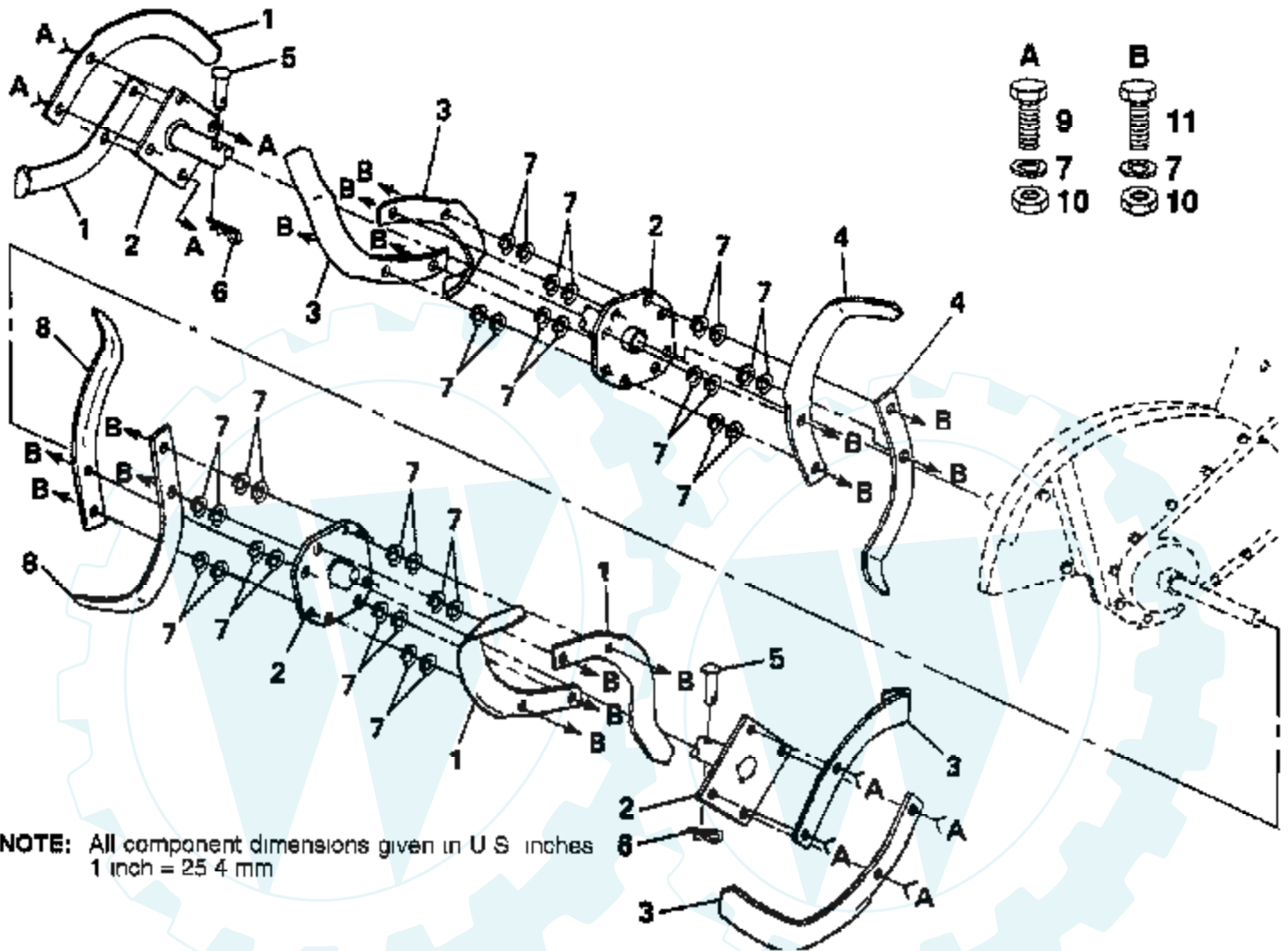

Ref #	Part Number	Qty	Description
1	6556J		SUB= 101194M
2	100445L		TINE ASSY CRT
3	6557J		SUB= 101193M
4	101194M		TINE.LH.CRT
5	4929H		RIVET.PAN HD.1.75
6	3146R		RETAINER.SPRING
7	10040600		LOCKWASHER
8	101193M		TINE RH CRT
9	74610616		BOLT
10	73610600		SUB= 7810H
11	74610624		BOLT.3/8-24X1-1/2

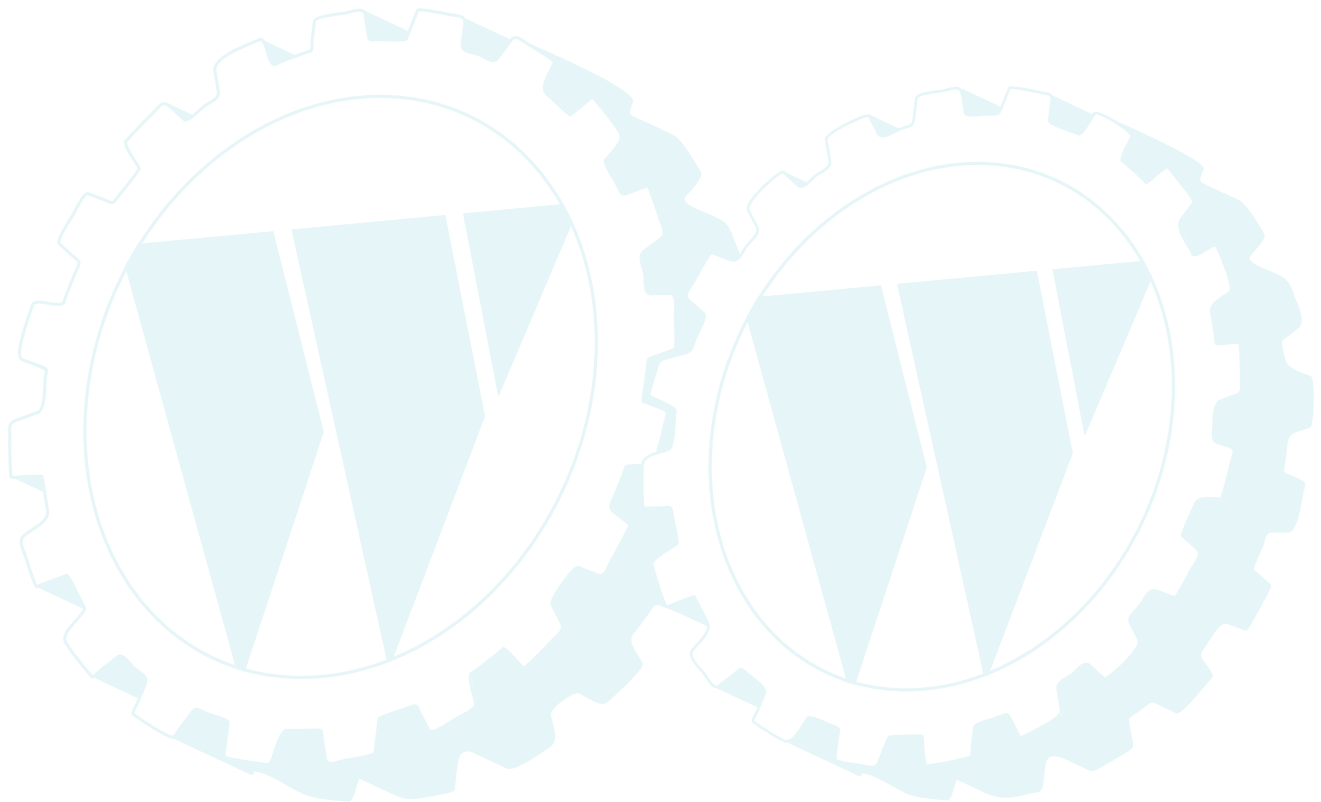

TILLER -- MODEL NUMBER TS821C

TINE SHIELD

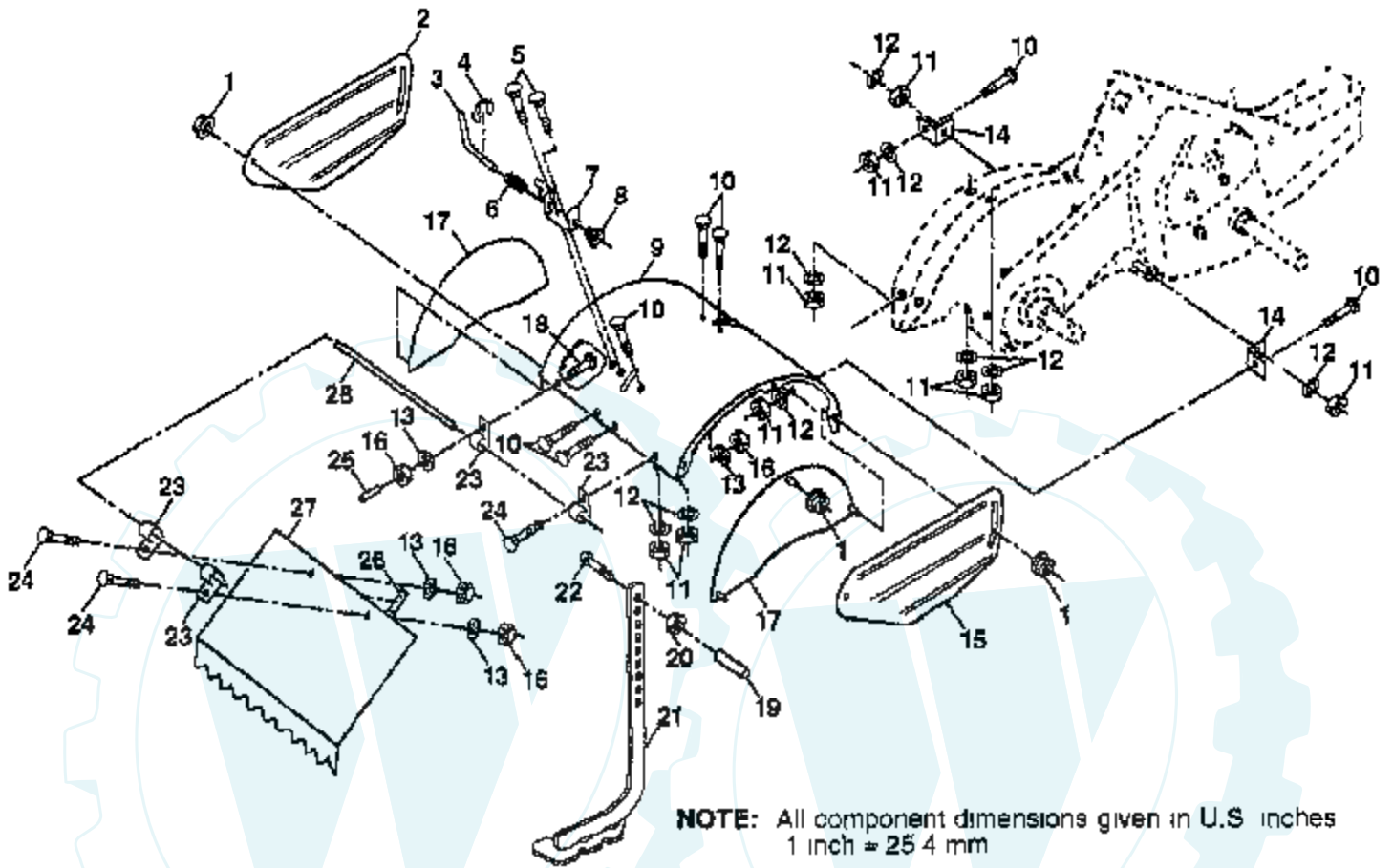

Ref #	Part Number	Qty	Description
1	98000129		NUT
2	108711X505		SHIELD SIDE OUT L
3	8393J		STAKE PIN TI
4	12000036		KLIP RING TI
5	72140508		BOLT
6	8394J		SPRING TI
7	8392J		LATCH BRACKET TI
8	109230X		SPRING CRT
9	104178X505		SHIELD TINE RED
10	72140506		BOLT
11	73220500		NUT.HEX.5/16-18
12	10040500		LOCKWASHER
13	10040400		LOCKWASHER
14	8386J		TINE SHLD BRKT TI
15	108710X505		SHIELD SIDE RH
16	73220400		SUB= 50675
17	104084X505		SHIELD SIDE RED
18	72040410		BOLT
19	102701X		GRIP CRT
20	73220600		NUT.HEX.3/8-16UNC
21	138420		STAKE.ASM.DEPTH
22	74930632		BOLT
23	4440J		HINGE CRT
24	72140408		BOLT.1/4-20X1/2
25	6712J		VINYL CAP TI
26	109227X		PAD IDLER TI
27	102713X505		SHIELD LEVELING
28	138609		PIN.HINGE

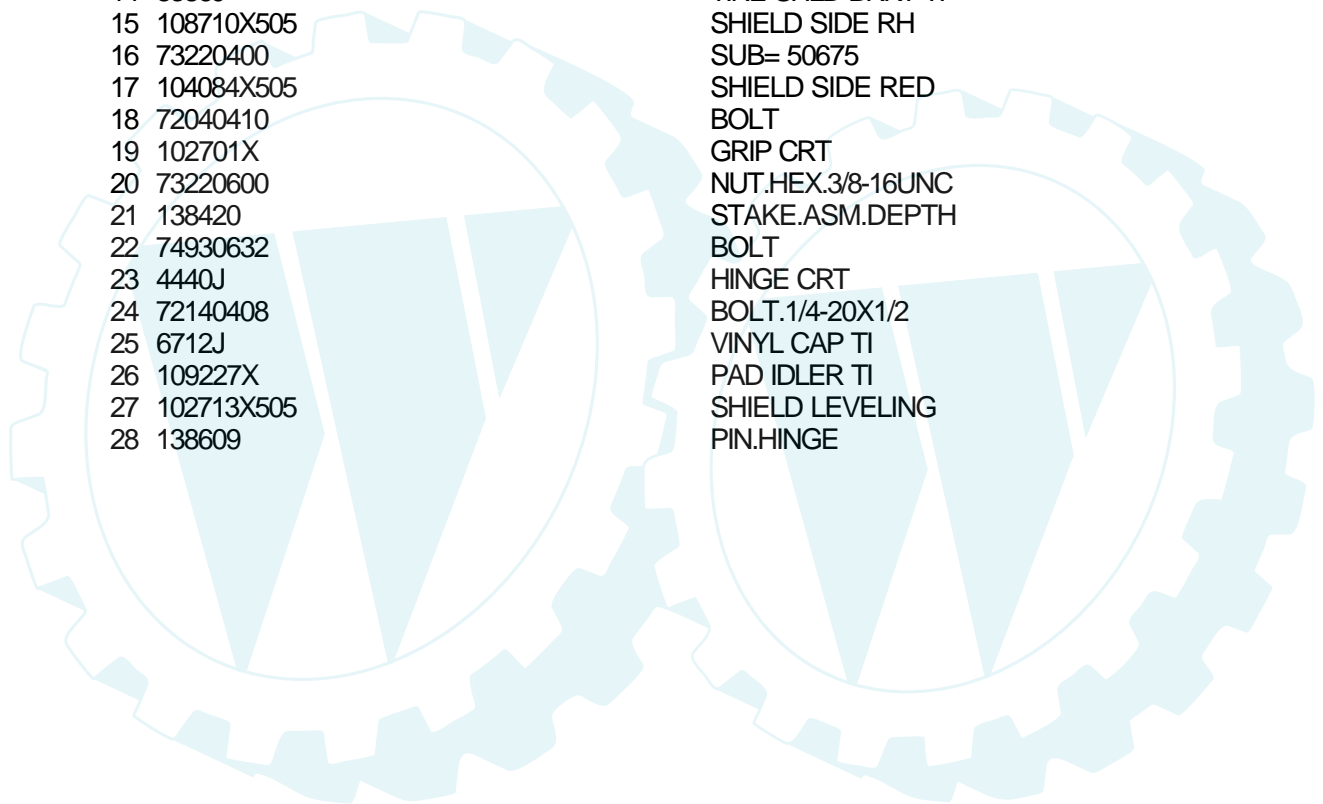

TILLER - - MODEL NUMBER TS821C

TRANSMISSION

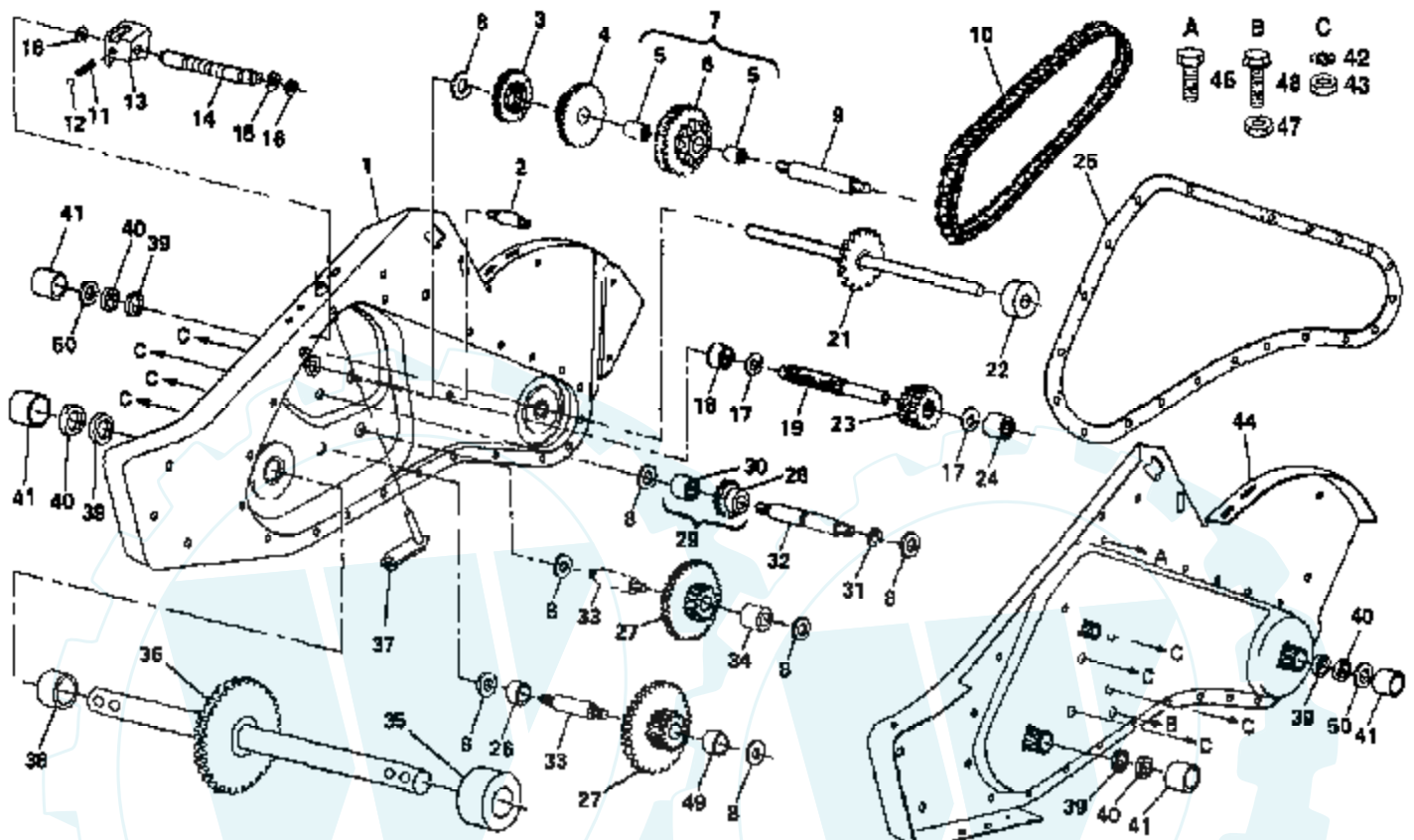

NOTE: All component dimensions given in U S inches
1 inch = 25.4 mm

Ref #	Part Number	Qty	Description
	150674		SUB= 162169
1	150430		SUB= 162170
2	8370J		BOLT TI
3	8547J		REVERSE GEAR TI
4	8546J		CLUSTER GEAR TI
5	100413K		"CRT, BEARING"
6	674A291		SUB= 674A290
7	674A290		SPROCKET ASSY TI
8	4358J		WASHER
9	8358J		REDUCTION SHFT TI
10	8371J		CHAIN TI
11	100371K		SPRING-SHIFT CRT
12	7392M		SUB= 100482K
13	8353J		SHIFT FORK TI
14	8354J		SHIFT SHAFT TI
15	12000039		KLIP RING
16	102136X		WASHER SEAL CRT
17	1370H		"T, BEARING"
18	4895H		"TI, BEARING"
19	150695		SHAFT INPUT
21	105378X		SHAFT TINE CRT
22	106181X		SPACER CRT
23	8359J		INPUT PINION TI
24	5020J		NEEDLE BRNG LT
25	8372J		GEARCASE GSKT TI
26	106389X		SPACER CRT
27	100433M		GEAR CLUSTER CRT
28	8357J		REVERSE GEAR TI
29	674A289		GEAR ASSY TI
30	6803J		NEEDLE BEARING TI
31	12000040		KLIP RING
32	8356J		REVERSE SHAFT TI
33	100016K		SHAFT CRT
34	106392X		SPACER CRT
35	106394X		SPACER CRT
36	100436L		SHAFT ASSY CRT
37	142145		BRACKET ASM SHIFT
38	106393X		SPACER CRT
39	7393R		OIL SEAL STD
40	140576		SEAL RING RUBBER
41	9672R		CUP.FORMED.
42	10040700		LOCKWASHER
43	73610700		NUT.ASF.HEX.7/16
44	150674		SUB= 162169
45	17720510		SCREW 5/16-18X5/8
47	73220500		NUT.HEX.5/16-18
48	100107K		BOLT TI
49	106391X		SPACER CRT
50	102144X		RING SPIRAL CRT
	6066J		GREASE PREMIUM-1