

TILLER - - MODEL NUMBER RY820D

DECALS

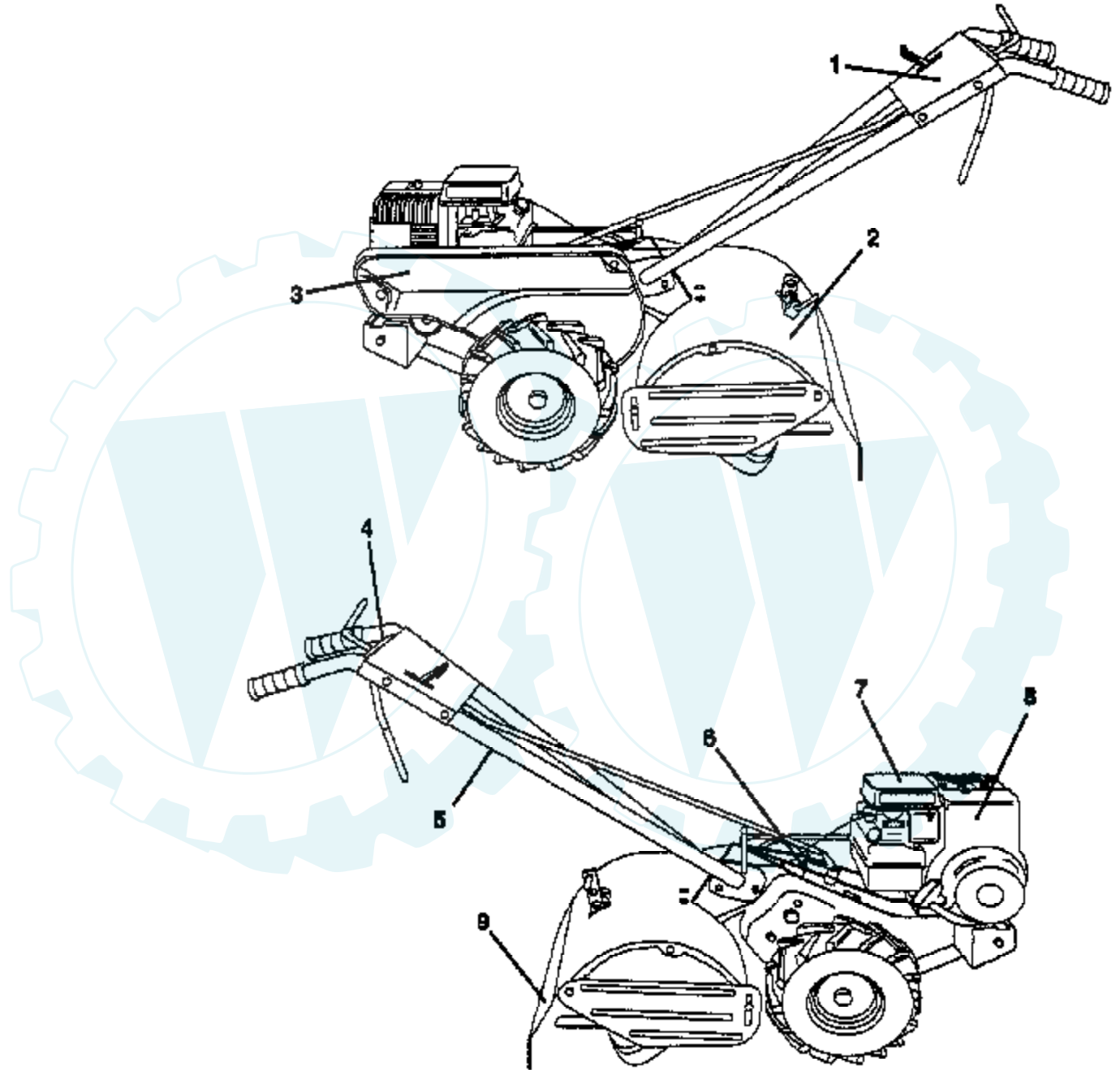

Ref #	Part Number	Qty	Description
1	128221		NLA
2	127210X		NLA
3	132316		DECAL, LOGO
4	110678X		NLA
5	110614X		DECAL TI
6	104323X		NLA
7	110612X		DECAL TI
8	271948		DECAL, BRIGGS & STRATTON
9	120076X		SUB= 120075X
	146250		MANUAL.RY820D
	146251		MANUAL.OWN.RY820D



TILLER - - MODEL NUMBER RY820D

HANDLE ASSEMBLY

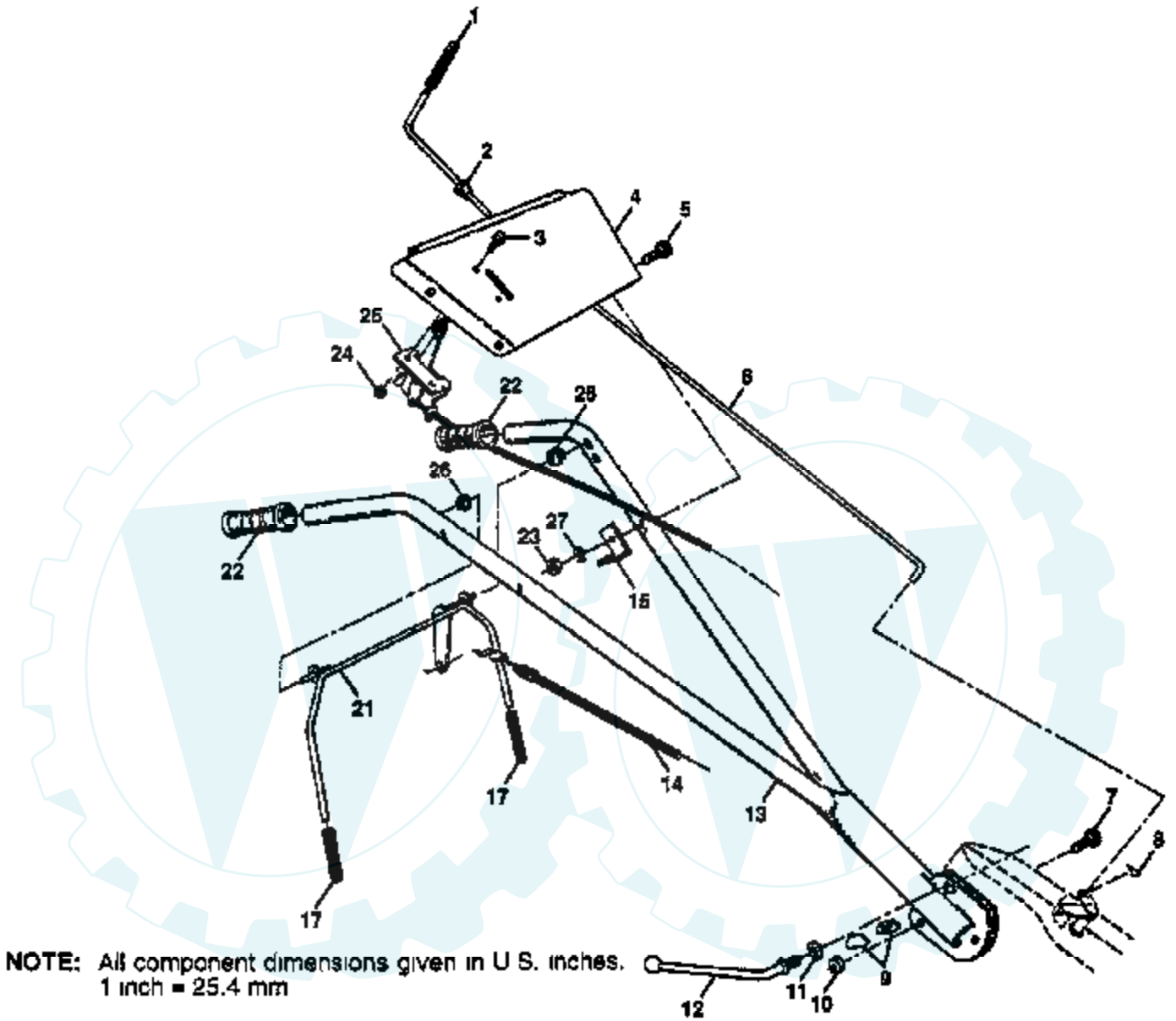

Ref #	Part Number	Qty	Description
1	8389J		GRIP TI
2	121248X		BUSHING
3	71191008		SCREW.PNHD.10-24
4	126949X505		HANDLE BRACKET
5	72110514		BOLT CARRIAGE CRT
6	108281X		ROD SHIFT CRT
7	72110608		BOLT D
8	4497H		RETAINER M
9	109229X		LOCK CRT
10	73930600		LOCKNUT
11	19131611		WASHER CRT
12	109228X		LEVER LOCK CRT
13	149314		HANDLE.ASM.V-PLOW
14	145820		CABLE.CLUTCH.Z-BE
15	145821		BRACKET.CLUTCH.CA
17	102604X		GRIP BAR CRT
21	145829		BAR.ASM.CNTRL.VPL
22	140526		GRIP HDLE NUBBED
23	73800500		NUT
24	73731000		NUT
25	127012X		"CONT,THROTTLE"
26	146480		GROMMET.HANDLE.V-
27	10040500		LOCKWASHER

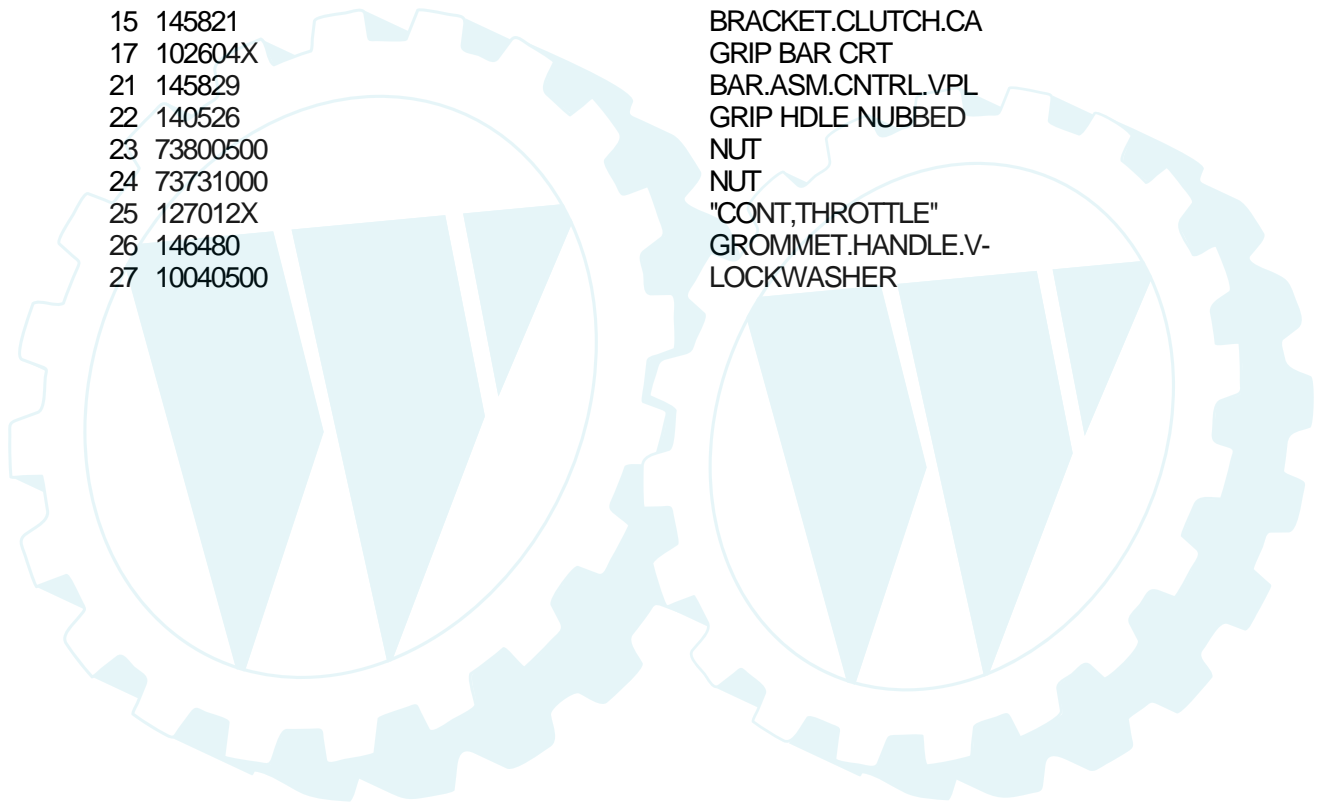

TILLER -- MODEL NUMBER RY820D

MAINFRAME, LEFT SIDE

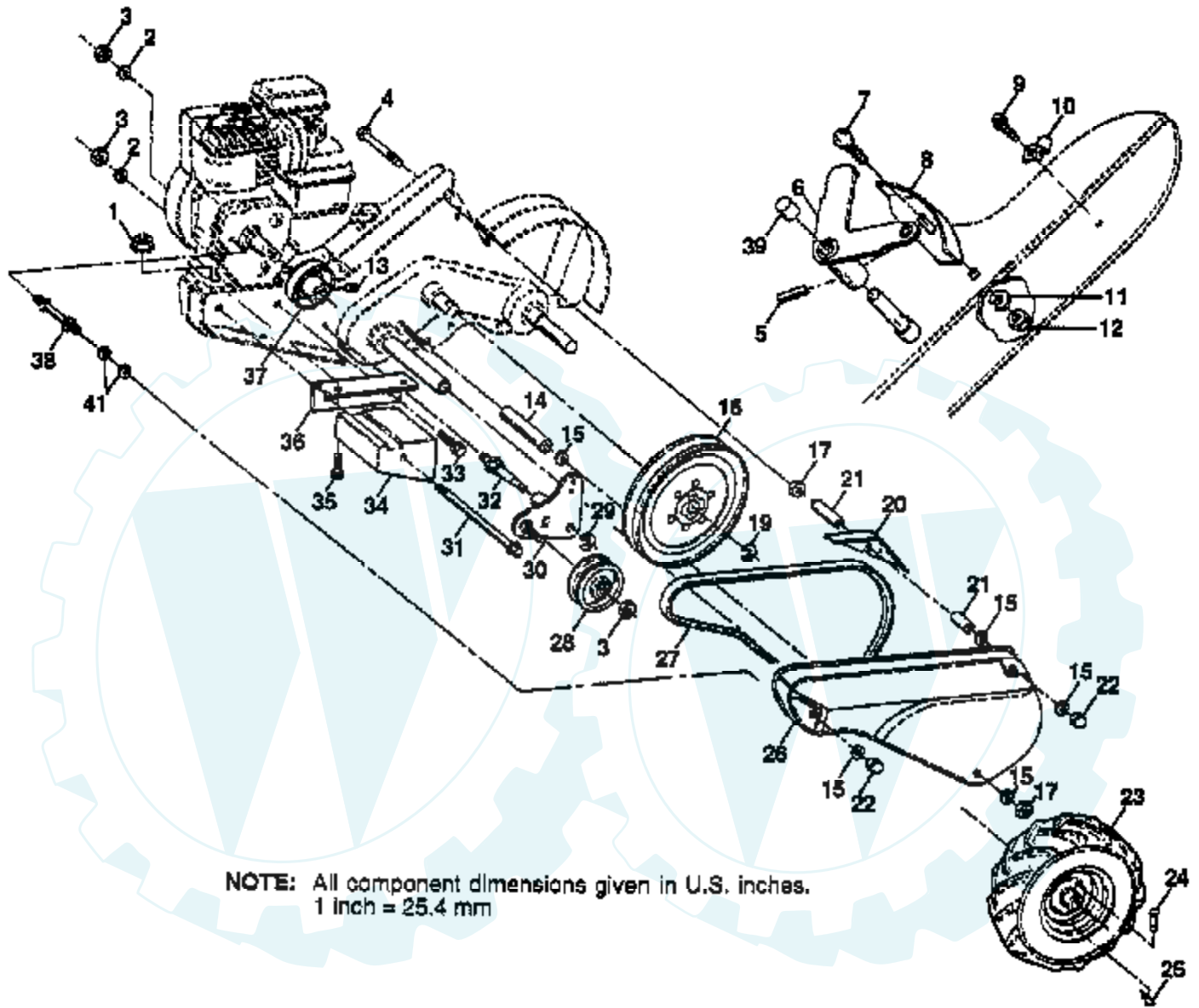

Ref #	Part Number	Qty	Description
1	73510500		NUT
2	10040600		LOCKWASHER
3	73220600		NUT.HEX.3/8-16UNC
4	74930568		BOLT TI
5	1572H		SUB= 2882J
6	110111X		LEVER ASM CRT
7	72110404		BOLT
8	8700J		PANEL TI
9	86777		SUB= 750097
10	9484R		CONDIUT CLIP T
11	10040400		LOCKWASHER
12	73220400		SUB= 50675
13	23230506		SET SCREW
14	120938X		SPACER
15	19111116		WASHER
16	145102		SHEAVE.TRANS.
17	73220500		NUT.HEX.5/16-18
19	12000028		SUB= 2267J
20	110653X		GUARD CRT
21	145216		SPACER.SPLIT
22	104214X		NUT TI
23	102190X		TIRE.CHV.13X5.0-6
	124258X		RIM
	795R		SUB= 65139
24	126875X		RIVET.DRILL.1.75
25	4497H		RETAINER M
26	131159X505		"GUARD, BELT"
27	132672		BELT-V
28	104679X		PULLEY-IDLER TI
29	12000032		KLIP RING
30	105611X		SUB= 918105611X
31	102384X		BOLT CRT
32	102141X		SHIFT ARM CRT
33	74760616		BOLT
34	102383X		COUNTERWEIGHT CRT
35	74760524		BOLT.HEX.5/16-1.5
36	102331X		BRACKET LH CRT
37	130816		ENGINE SHEAVE
38	145822		STUD.GUARD.BELT
39	140062		CAP PLUNGER BLACK
41	19111610		WASHER

TILLER - - MODEL NUMBER RY820D

MAINFRAME, RIGHT SIDE

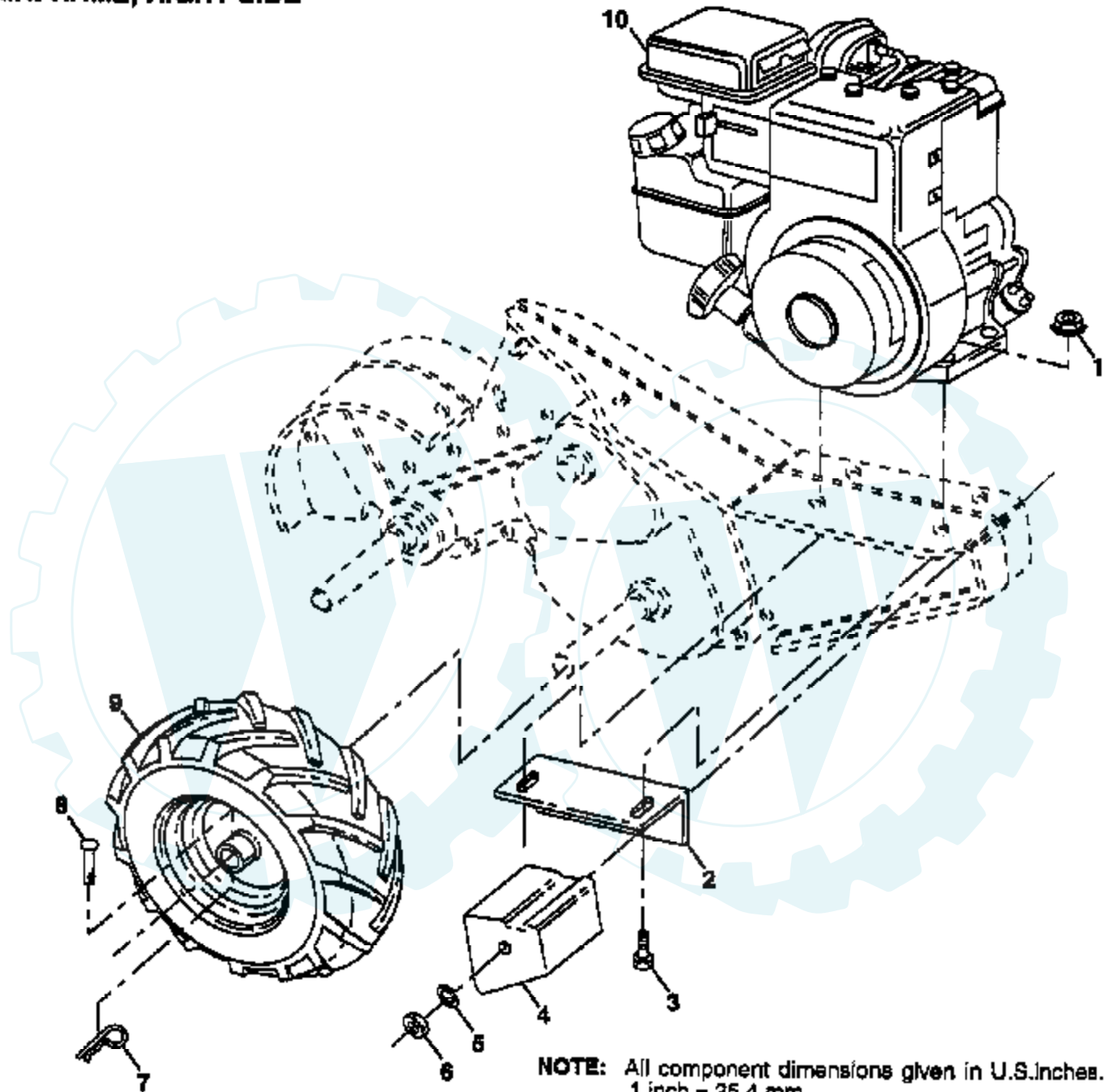

Ref #	Part Number	Qty	Description
1	73510500		NUT
2	102332X		BRACKET RH CRT
3	74760524		BOLT.HEX.5/16-1.5
4	102173X		COUNTERWEIGHT CRT
5	10040600		LOCKWASHER
6	73220600		NUT.HEX.3/8-16UNC
7	4497H		RETAINER M
8	126875X		RIVET.DRILL.1.75
9	102190X		TIRE.CHV.13X5.0-6
	124258X		RIM
	795R		SUB= 65139
10			REFER TO IMAGE



TILLER - - MODEL NUMBER RY820D

TINE ASSEMBLY

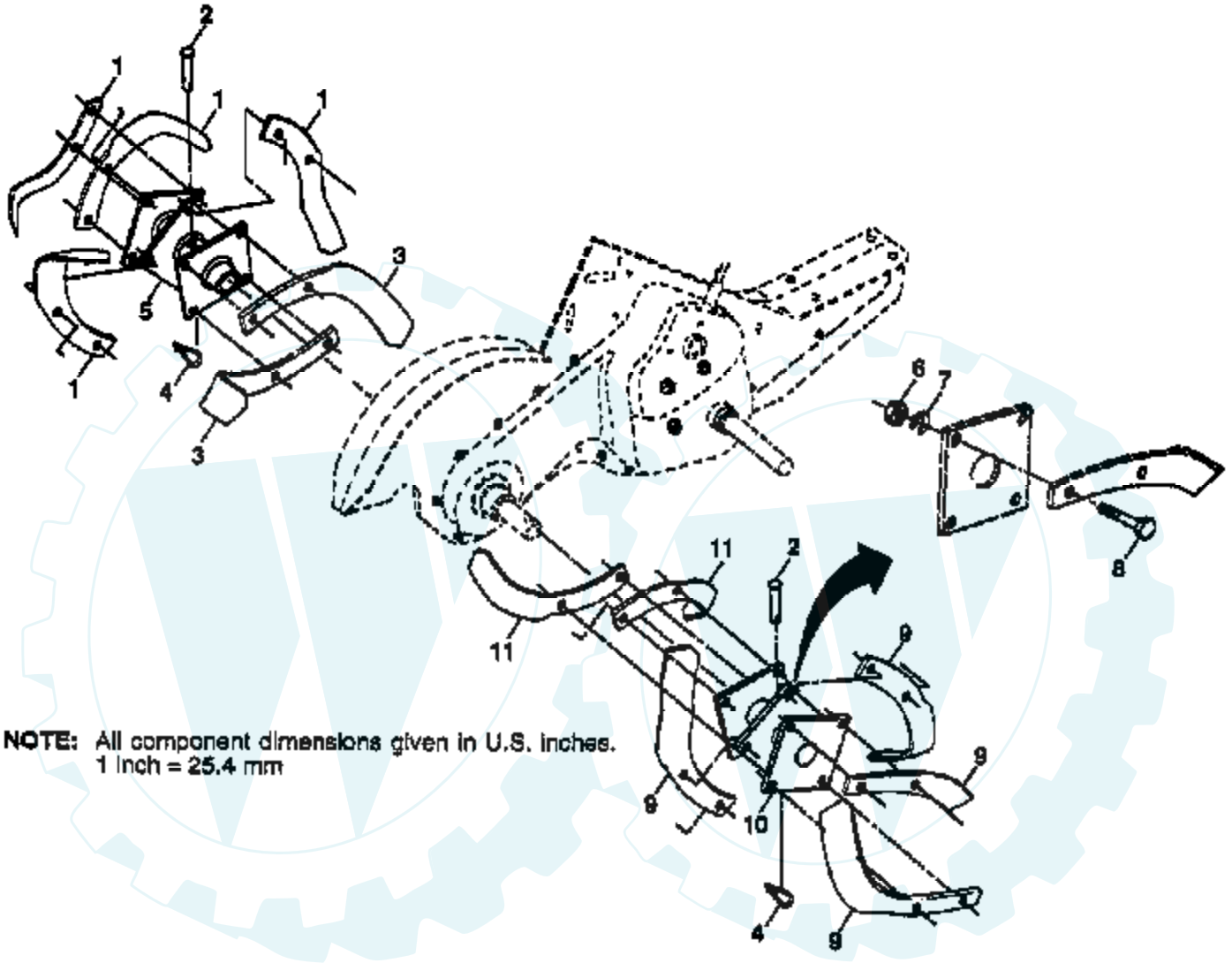

NOTE: All component dimensions given in U.S. inches.
1 inch = 25.4 mm

Ref #	Part Number	Qty	Description
1	4459J		SUB= 6554J
2	132673		PIN.CLEVIS.SHEAR
3	6554J		"TINE.LH.12""
4	3146R		RETAINER.SPRING
5	132727		HUB&PLATE ASM LH
6	73610600		SUB= 7810H
7	10040600		LOCKWASHER
8	74610616		BOLT
9	4460J		SUB= 6555J
10	132728		HUB&PLATE ASM RH
11	6555J		"TINE.RH.12""



TILLER -- MODEL NUMBER RY820D

TINE SHIELD

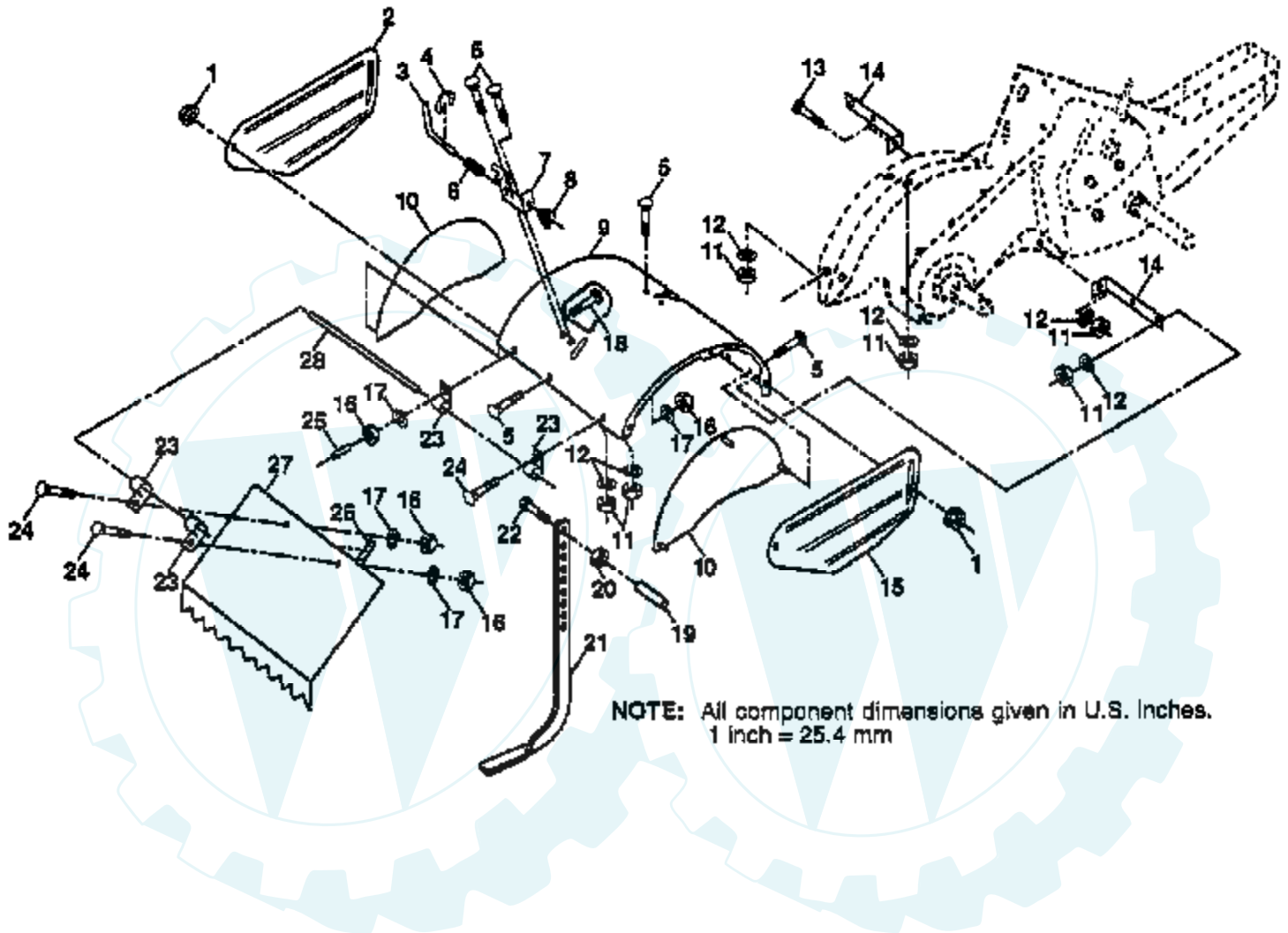

Ref #	Part Number	Qty	Description
1	98000129		NUT
2	104086X505		SHIELD.SD.OUT.LH
3	8393J		STAKE PIN TI
4	12000036		KLIP RING TI
5	72140506		BOLT
6	8394J		SPRING TI
7	8392J		LATCH BRACKET TI
8	109230X		SPRING CRT
9	102326X505		"SHIELD, TINE"
10	104085X505		"SHIELD, SIDE"
11	73220500		NUT.HEX.5/16-18
12	10040500		LOCKWASHER
13	72110510		BOLT
14	124343X		BRKT SHIELD TINE
15	104101X505		SHIELD.SD.OUT.RH
16	73220400		SUB= 50675
17	10040400		LOCKWASHER
18	72040410		BOLT
19	102701X		GRIP CRT
20	73220600		NUT.HEX.3/8-16UNC
21	102156X500		STAKE DEPTH 16
22	74930632		BOLT
23	4440J		HINGE CRT
24	72140404		BOLT
25	6712J		VINYL CAP TI
26	109227X		PAD IDLER TI
27	102695X505		LEVELING SHIELD
28	120588X		PIN HINGE

TILLER - - MODEL NUMBER RY820D

TRANSMISSION

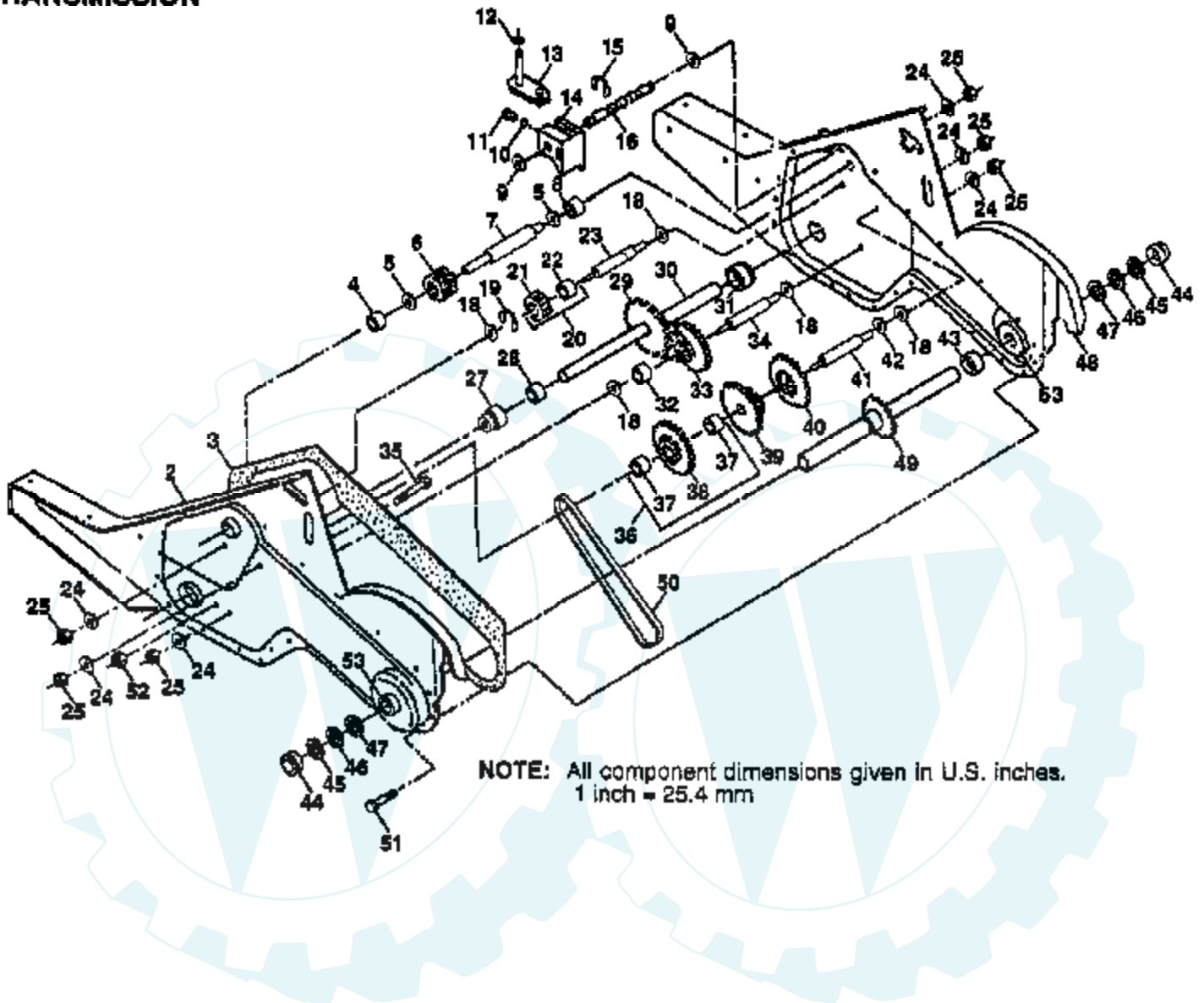

Ref #	Part Number	Qty	Description
1	145840		SUB= 155112
2	139544		SUB= 150698
3	106211X		GASKET TI
4	5020J		NEEDLE BRNG LT
5	1370H		"T, BEARING"
6	137335		GEAR PINION INPUT
7	145101		"SHAFT.INPUT."D""
8	4895H		"TI, BEARING"
9	102136X		WASHER SEAL CRT
10	7392M		SUB= 100482K
11	100371K		SPRING-SHIFT CRT
12	106160X		O-RING TI
13	142145		BRACKET ASM SHIFT
14	8353J		SHIFT FORK TI
15	12000039		KLIP RING
16	140525		SHAFT.SHIFT.4.250
18	4358J		WASHER
19	12000040		KLIP RING
20	102114X		GEAR ASSY CRT
21	102115X		GEAR-REV IDLR CRT
22	6803J		NEEDLE BEARING TI
23	102111X		SHAFT CRT
24	10040700		LOCKWASHER
25	73610700		NUT.ASF.HEX.7/16
27	143009		BEARING.SHAFT.LH.
28	106390X		BUSHING TI
29	102134X		CHAIN CRT
30	109204X		SUB= 150737
31	143008		BEARING.SHAFT.RH.
32	106388X		SPACER TI
33	102121X		SPRCKT 8 GEAR CRT
34	102112X		SHFT 2ND RED. CRT
35	102101X		SCRW WHIZ LOK CRT
36	137300		SPROCKET ASM.
37	4422J		BEARING
38	137301		SUB= 137300
39	105345X		GEAR TI
40	105346X		GEAR TI
41	8358J		REDUCTION SHFT TI
42	4220R		BRNG RACE
43	106146X		SPACER TI
44	9672R		CUP.FORMED.
45	102144X		RING SPIRAL CRT
46	140576		SEAL RING RUBBER
47	7393R		OIL SEAL STD
48	139546		SUB= 150700
49	132688		TINE SHAFT
50	106147X		CHAIN.50 LINK TI
51	17580408		SCREW CRT
52	73220500		NUT.HEX.5/16-18
53	122204X		SUB= 918122204X
	6066J		GREASE PREMIUM-1