

TILLER - - MODEL NUMBER FN850C

BELT GUARD AND PULLEY ASSEMBLY

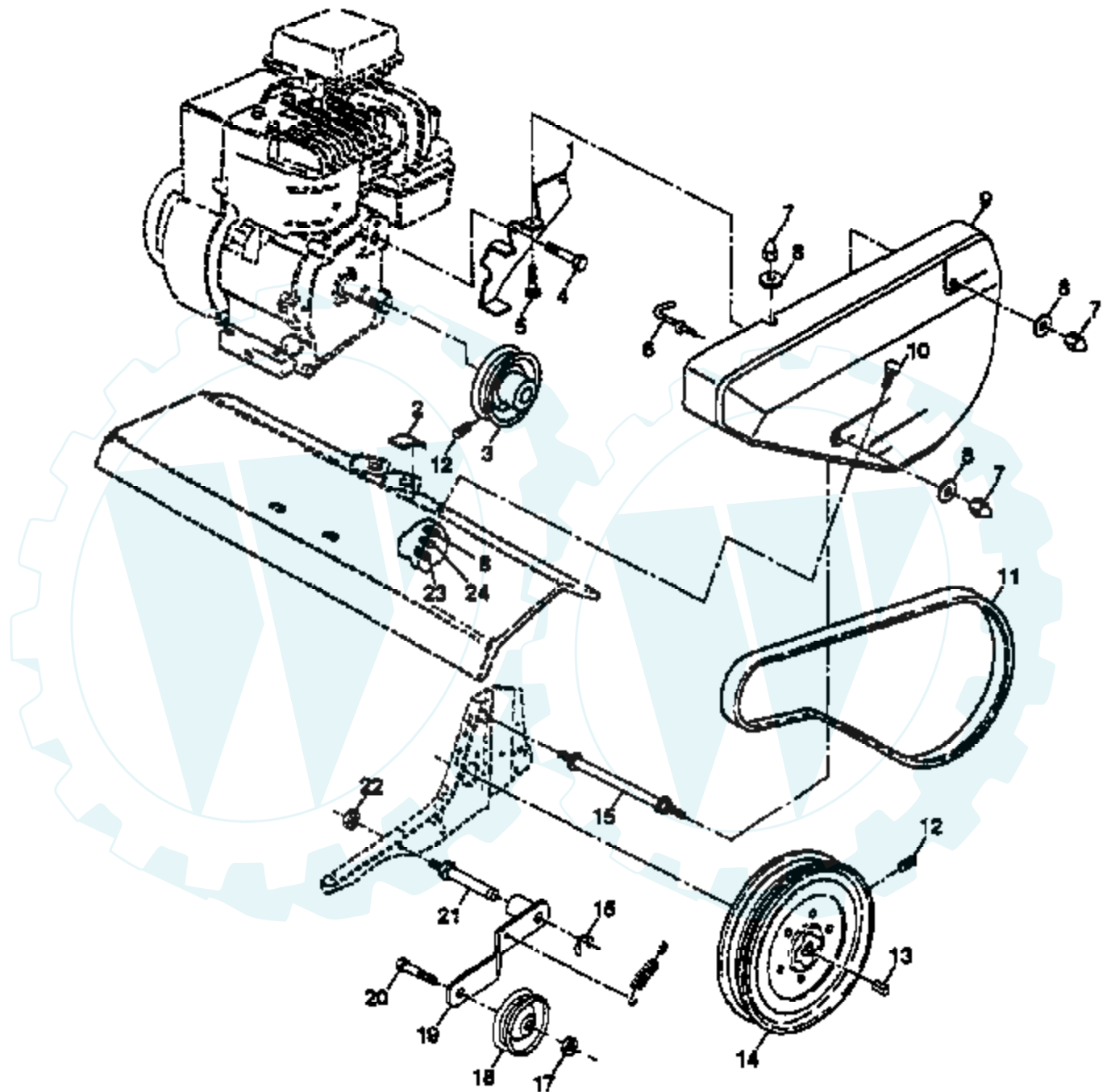

NOTE: All component dimensions given in U.S. inches.
1 inch = 25.4 mm

Ref #	Part Number	Qty	Description
1	121313X		SUB= 159233
2	109227X		PAD IDLER TI
3	130812		ENGINE PULLEY
4	74770812		SCREW
5	72140404		BOLT
6	121463X		KEEPER BELT
7	104213X		NUT-CAP TI
8	19091016		WASHER
9	131158X505		"GUARD, BELT"
10	72140405		BOLT T
11	9180R		V BELT STD
12	23230506		SET SCREW
13	2649M		KEY T
14	9175R		TRANS SHEAVE RT
15	110528X		BOLT TI
16	12000036		KLIP RING TI
17	73350600		NUT
18	9178R		SUB= 75673
19	674A30		IDLER ARM TI
20	74760620		SUB= 74780620
21	106968X		SHAFT IDLER TI
22	73350500		JAM NUT TI
23	73220400		SUB= 50675
24	10040400		LOCKWASHER

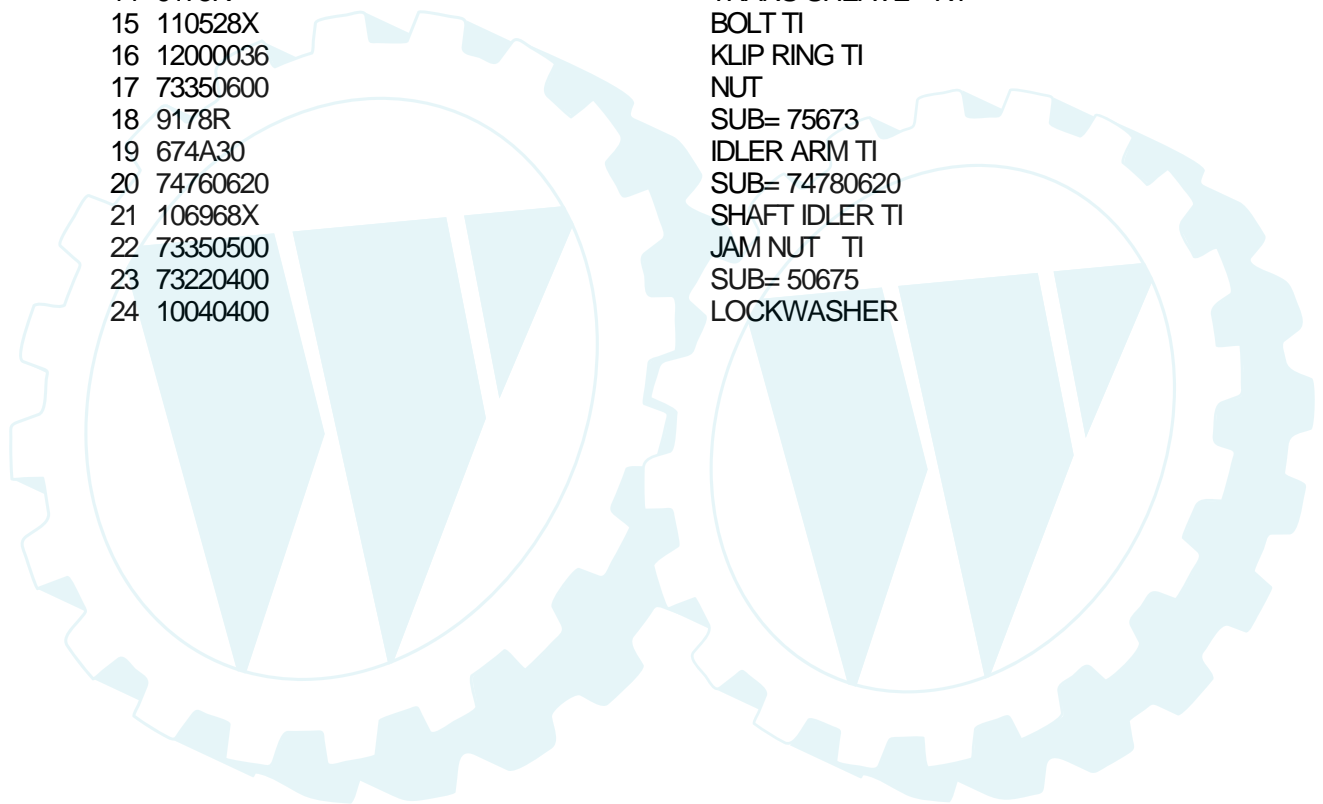

TILLER - - MODEL NUMBER FN850C

DECALS

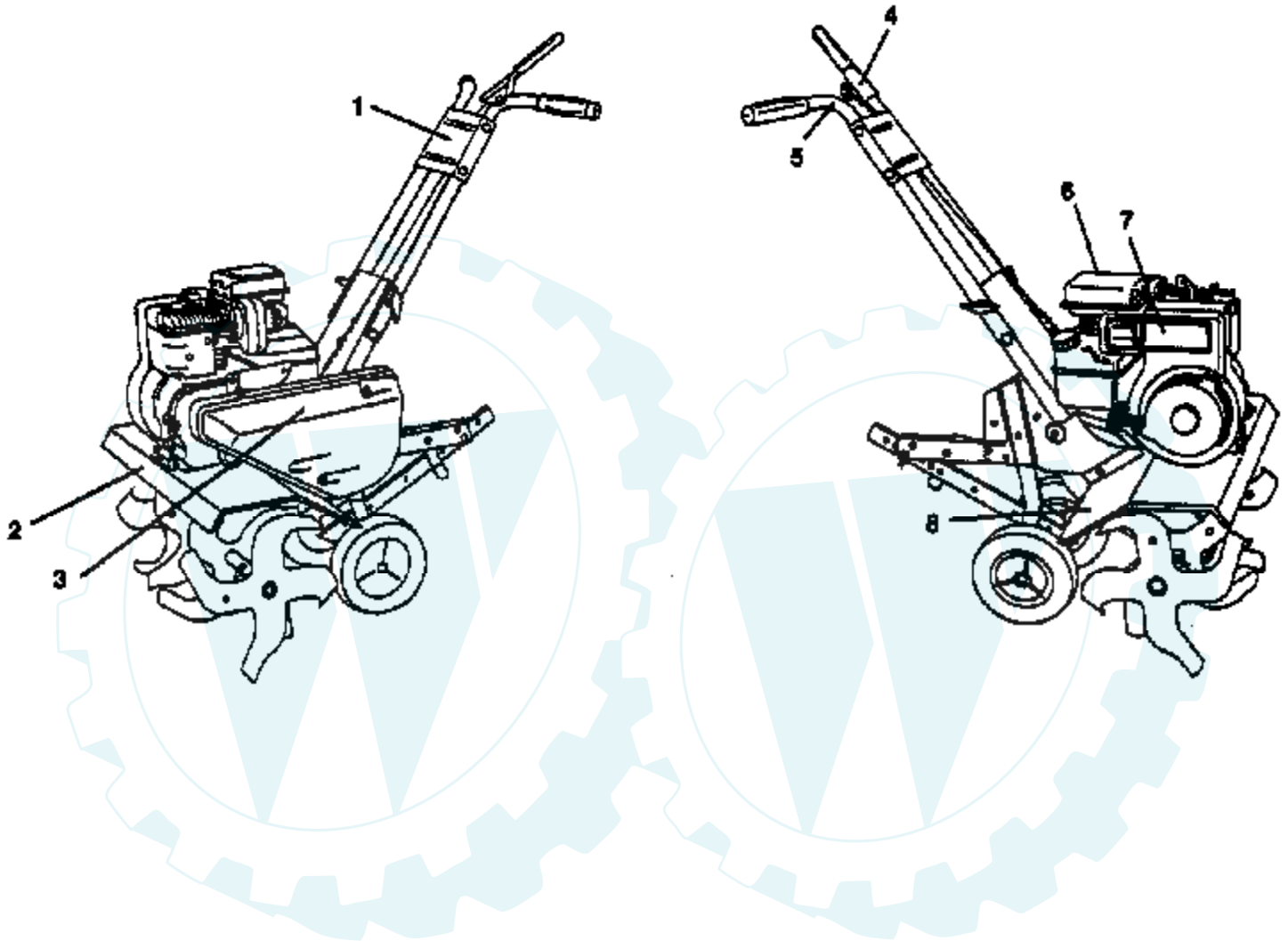

Ref #	Part Number	Qty	Description
1	132629		DECAL HANDLE BRKT
2	127185X		DECAL TINE SHIELD
3	132549		BELT.GUARD.DECAL
4	110613X		DECAL TI
5	110614X		DECAL TI
6	110612X		DECAL TI
7	271948		DECAL, BRIGGS & STRATTON
8	120076X		SUB= 120075X
	146213		MAN.OWN.FN850C.EN
	146214		MAN.OWN.FN850C.FR



TILLER - - MODEL NUMBER FN850C

HANDLE ASSEMBLY

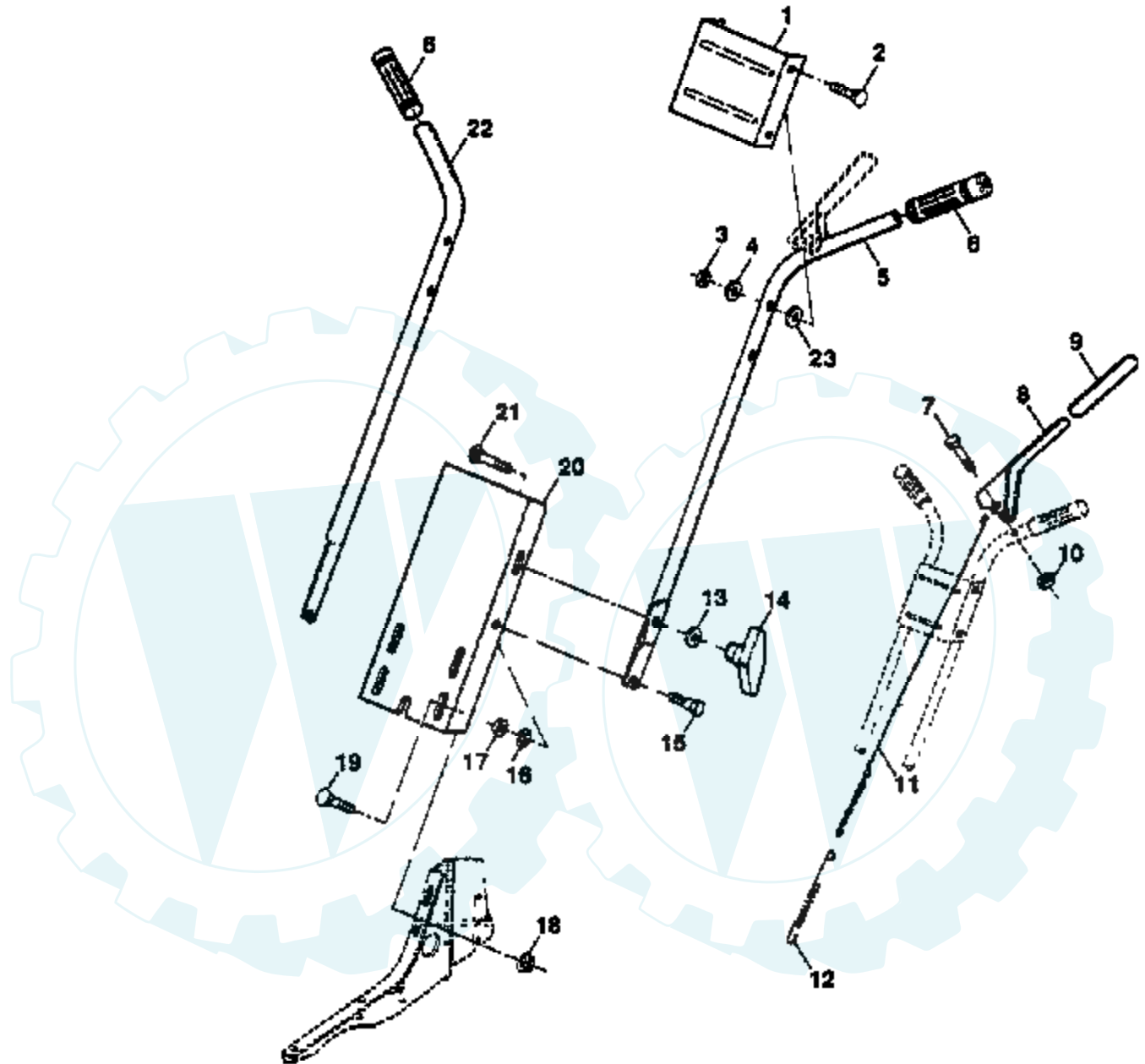

NOTE: All component dimensions are given in U.S. inches.
1 inch = 25.4 mm

Ref #	Part Number	Qty	Description
1	137176X505		HANDLE BRKT
2	72140512		BOLT
3	73680500		SUB= 73690500
4	19111116		WASHER
5	2621J500		SUB= 154127
6	140536		GRIP NUB DOUBLE
7	74760524		BOLT.HEX.5/16-1.5
8	3069J		SUB= 164937
9	8206H		GRIP T
10	1685H		SUB= 68478
11	3067J		SUB= 100382K
12	3070J		SPRING EXT TI
13	19121414		WASHER
14	136376		KNOB HANDLE
15	471J		BOLT CT
16	10040500		LOCKWASHER
17	73220500		NUT.HEX.5/16-18
18	98000129		NUT
19	72140506		BOLT
20	9209R505		PANEL. HANDLE
21	72110508		BOLT CRT
22	2622J500		SUB= 159764
23	19131312		WASHER

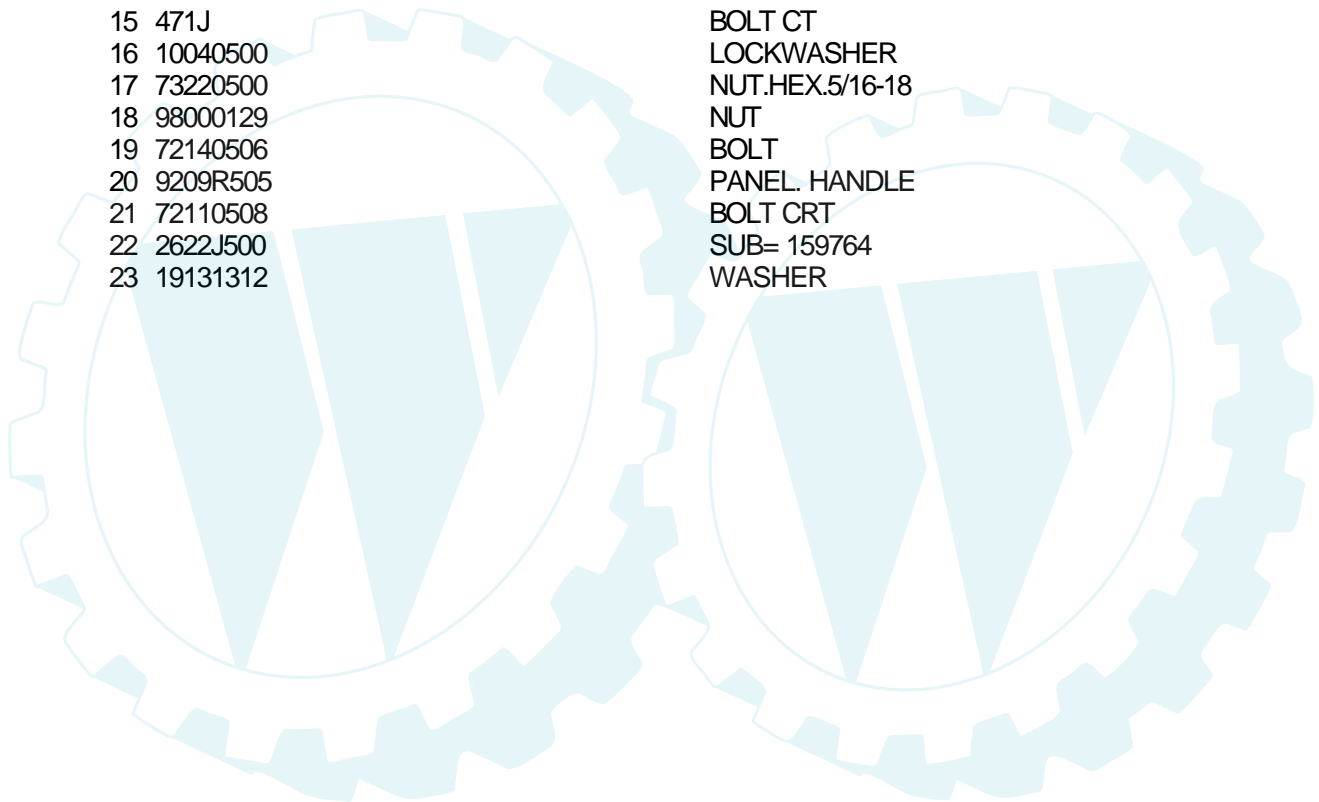

TILLER - - MODEL NUMBER FN850C

TINE ASSEMBLY

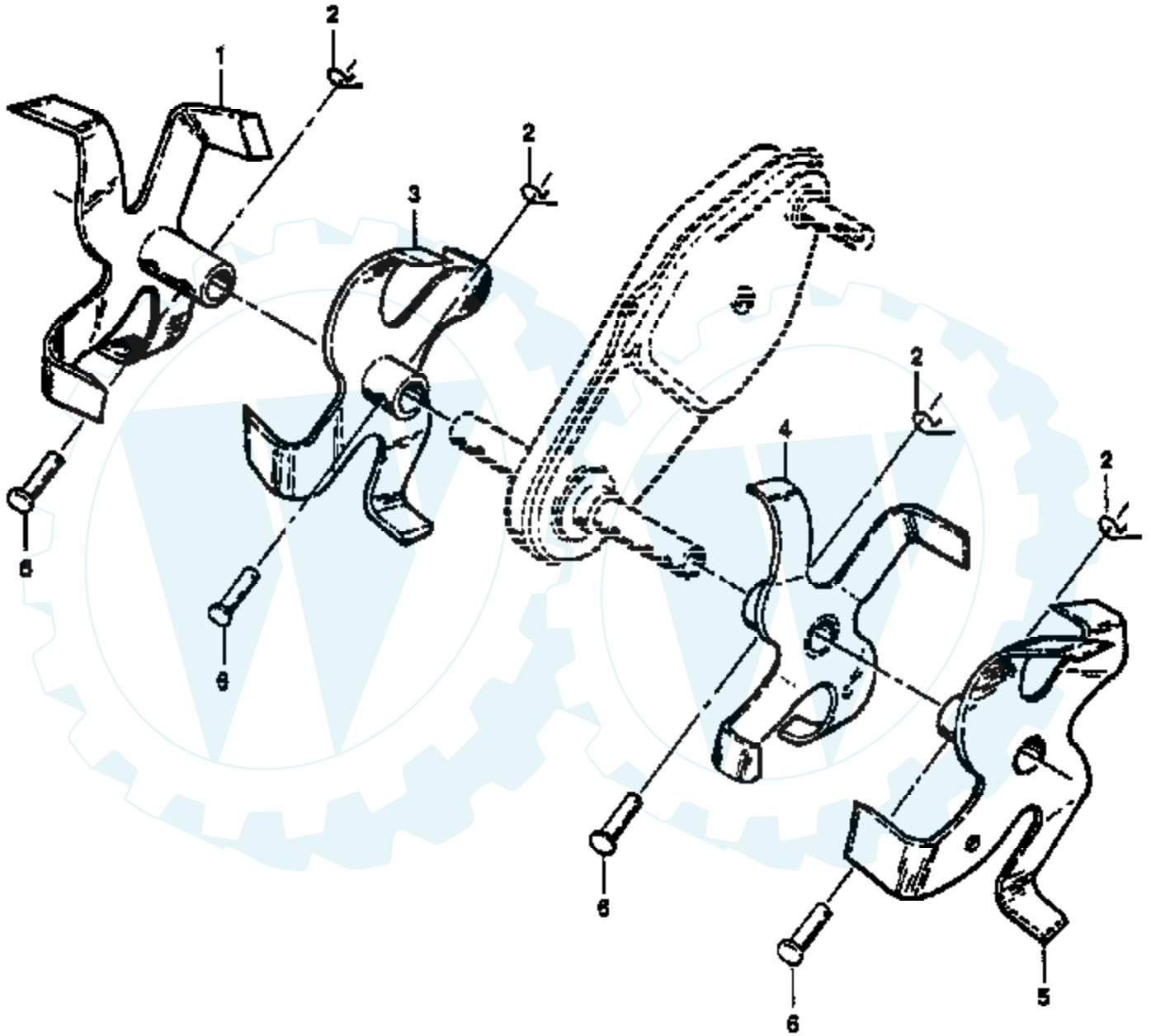

Ref #	Part Number	Qty	Description
1	674A66		TINE OUTER RH T
2	3146R		RETAINER.SPRING
3	674A64		SUB= 156924
4	674A63		TINE.INNER.LH
5	674A65		TINE.OUTER.LH.T
6	4929H		RIVET.PAN HD.1.75



TILLER - - MODEL NUMBER FN850C

TRANSMISSION

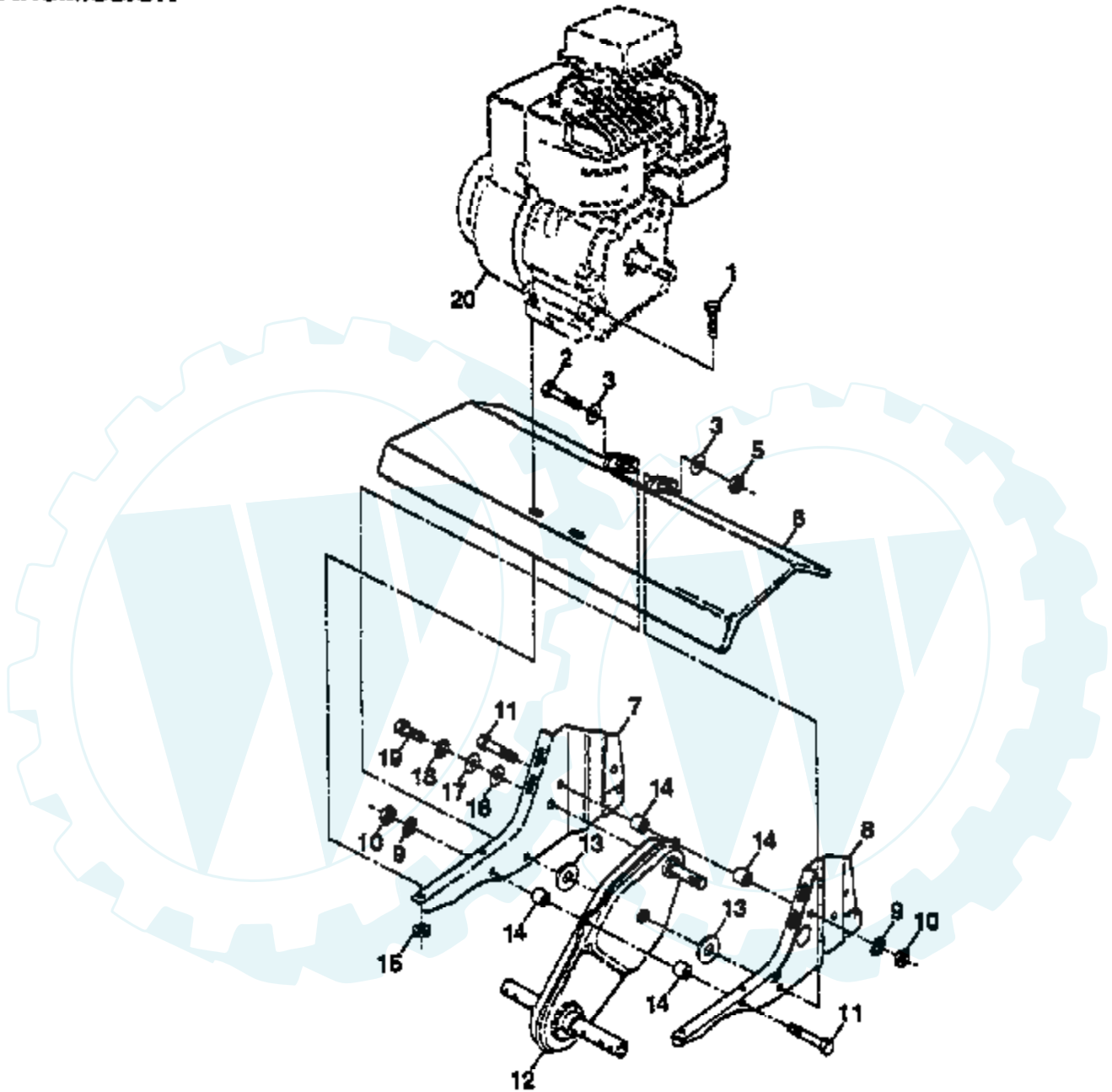

NOTE: All component dimensions given in U.S. inches.
1 inch = 25.4 mm

Ref #	Part Number	Qty	Description
1	74760524		BOLT.HEX.5/16-1.5
2	74780652		BOLT HEX 3/8-16
3	19131311		WASHER
5	73800600		NUT
6	9056R505		"SHIELD, TINE"
7	1949J500		SUB= 9181949J500
8	110519X500		SUB= 110519X
9	10040500		LOCKWASHER
10	73220500		NUT.HEX.5/16-18
11	74760544		SUB= 74780544
12	126669X		SUB= 532126669
14	9173R		SPLIT SPACER RT
15	73510500		NUT
16	19091412		WASHER
17	19092016		WASHER
18	10040400		LOCKWASHER
19	74610412		BOLT
20			REFER TO IMAGE

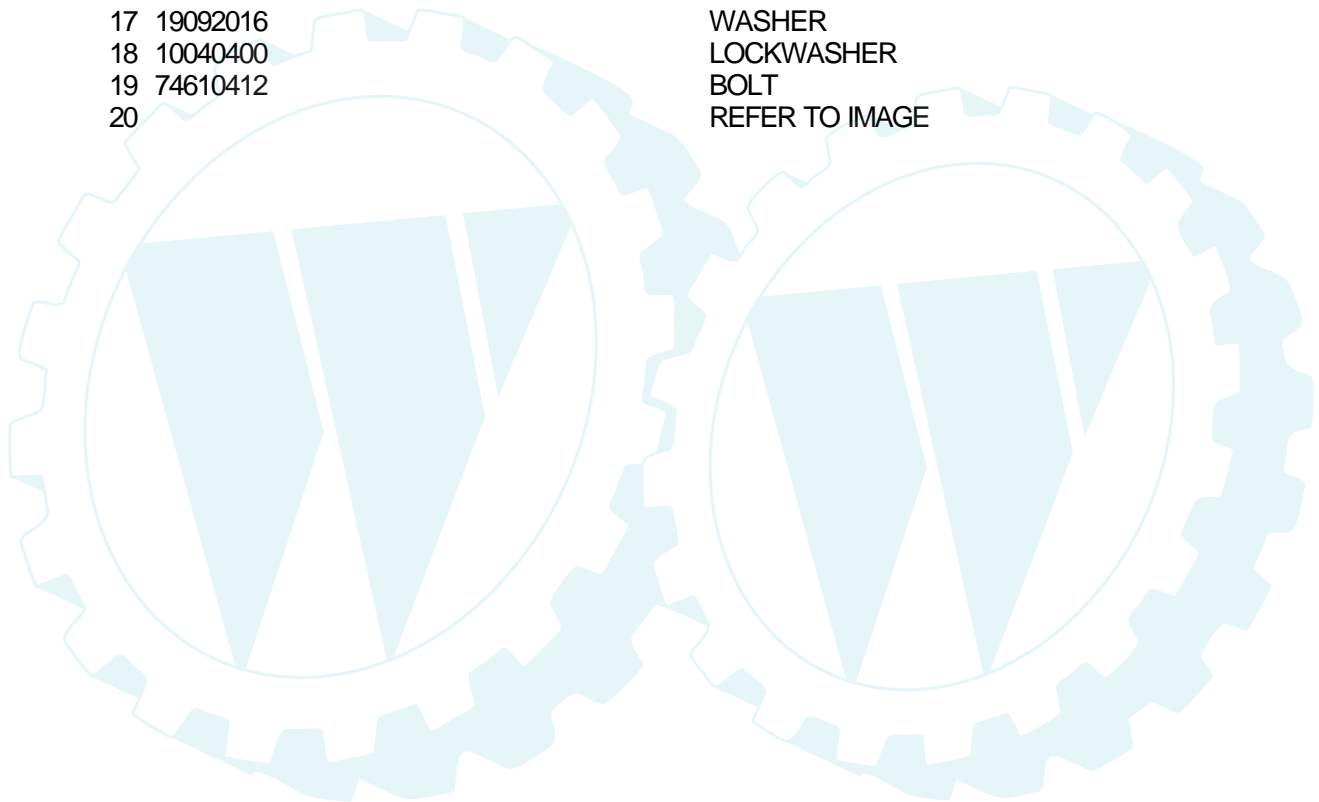

TILLER - - MODEL NUMBER FN850C

WHEEL AND DEPTH STAKE ASSEMBLY

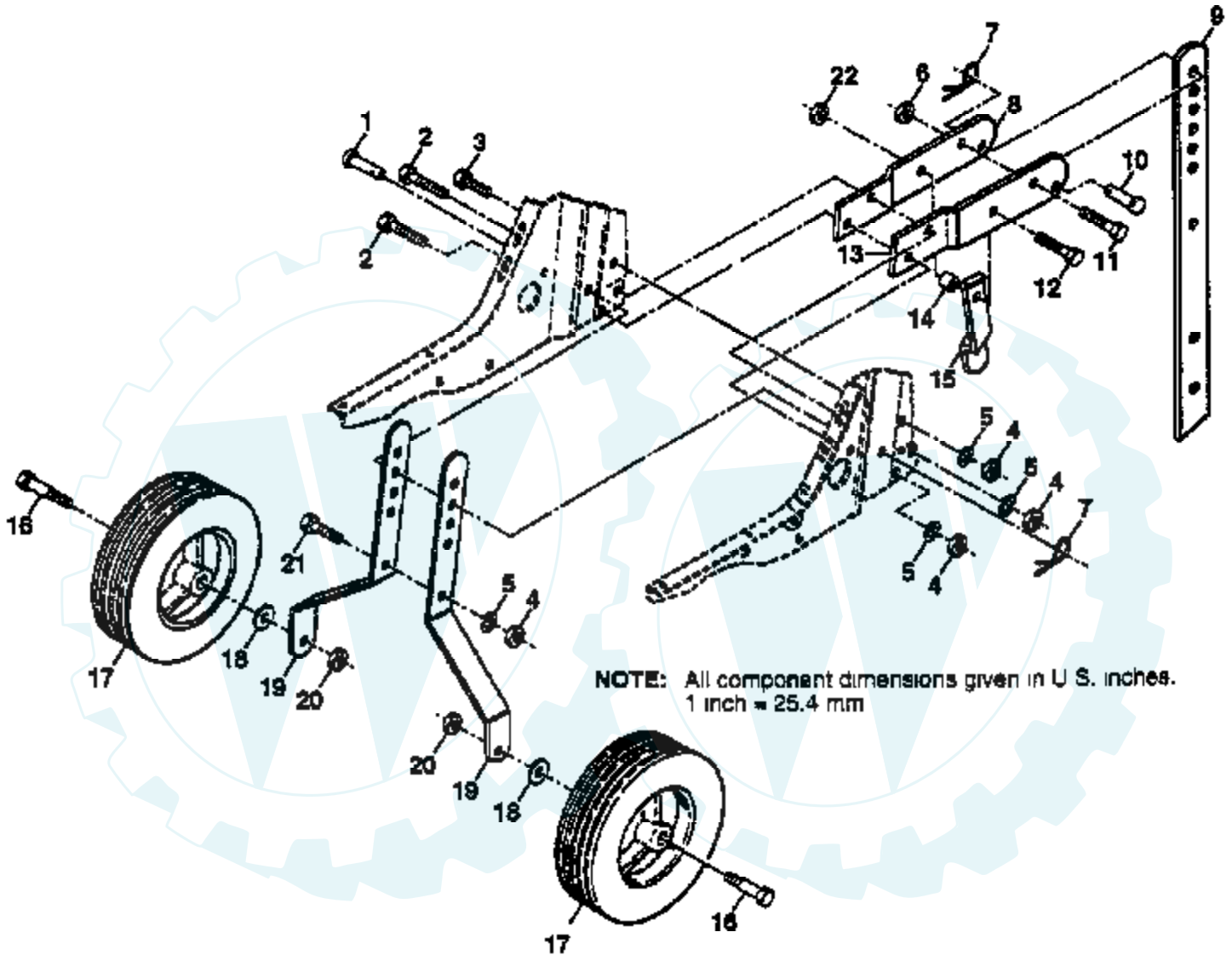

Ref #	Part Number	Qty	Description
1	9194R		DRILLED RIVET RT
2	74760520		BOLT
3	74760512		BOLT
4	73220500		NUT.HEX.5/16-18
5	10040500		LOCKWASHER
6	73800600		NUT
7	4921H		SPRING.RETAINER
8	1952J500		SUPPORT STAKE RH
9	122233X		SUB= 2582J
10	326J		SUB= 4929H
11	74780628		BOLT
12	74760524		BOLT.HEX.5/16-1.5
13	1951J500		SUPPORT STAKE LH
14	120958X		WASHER
15	5388J		STAKE SPRING TI
16	121117X		BOLT SHOULDER
17	9188R		SUB= 107644X
18	19131311		WASHER
19	9190R500		BRACKET.WHL.PNT.
20	73680600		SUB= 73690600
21	74760516		SUB= 77394
22	73800500		NUT

