

5 HP 17" TILLER - - MODEL NO. 95220 (952201)

DECALS

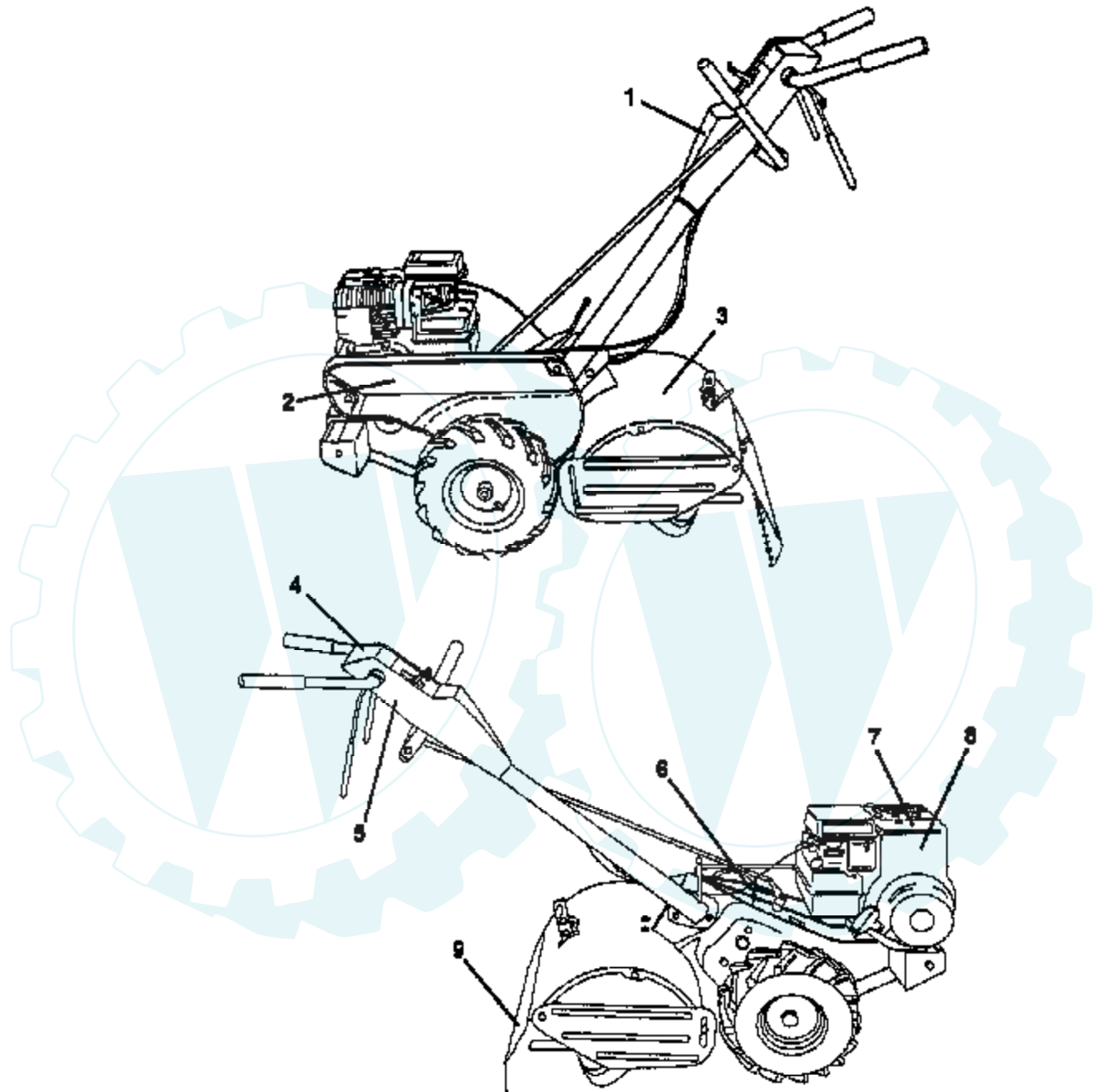

Ref #	Part Number	Qty	Description
1	138988		DECAL.PANEL.CONTR
2	138987		DECAL.GUARD.BELT
3	139025		SUB= 139011
4	136943		DECAL.INSTRUCTION
5	120431X		DECAL TI
6	102180X		DECAL CRT
7	110593X		SUB= 121858X
8	121543X		SUB= 271948
9	120075X		DECAL TI
	138659		MANUAL.O.952201



5 HP 17" TILLER - - MODEL NUMBER 95220 (952201)

HANDLE ASSEMBLY

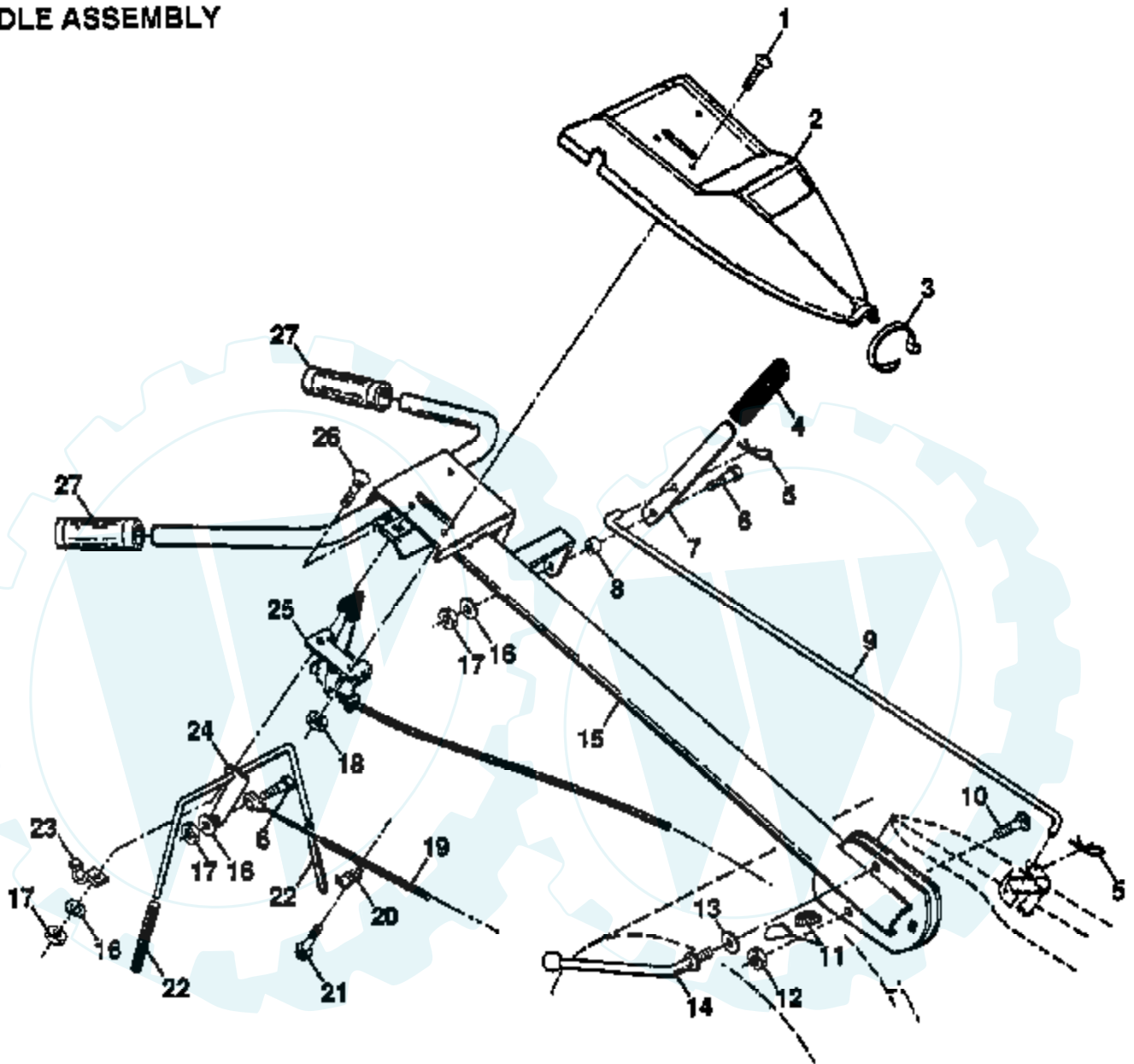

NOTE: All component dimensions given in U.S. inches.
1 Inch = 25.4 mm

Ref #	Part Number	Qty	Description
1	71091008		SCREW
2	126951X		"PANEL,CONT TI"
3	104164X		TIE CABLE CRT
4	8206H		GRIP T
5	4497H		RETAINER M
6	81328		SHOULDER BOLT ST
7	109335X		SHIFT HANDLE CRT
8	109313X		GROMMET CRT
9	109337X		SHIFT ROD CRT
10	72110608		BOLT D
11	109229X		LOCK CRT
12	73930600		LOCKNUT
13	19131611		WASHER CRT
14	109228X		LEVER LOCK CRT
15	127013X520		SUB= 155117
16	10040400		LOCKWASHER
17	73220400		SUB= 50675
18	73731000		NUT
19	102162X		CABLE.CLUTCH.CRT
20	9484R		CONDIUT CLIP T
21	86777		SUB= 750097
22	102604X		GRIP BAR CRT
23	102744X		SUB= 102744X431
24	105216X		"ASSY CONTROL, BAR"
25	127012X		"CONT,THROTTLE"
26	72140404		BOLT
27	9266R		SUB= 624A78

5 HP 17" TILLER - - MODEL NUMBER 95220 (952201)

MAINFRAME, LEFT SIDE

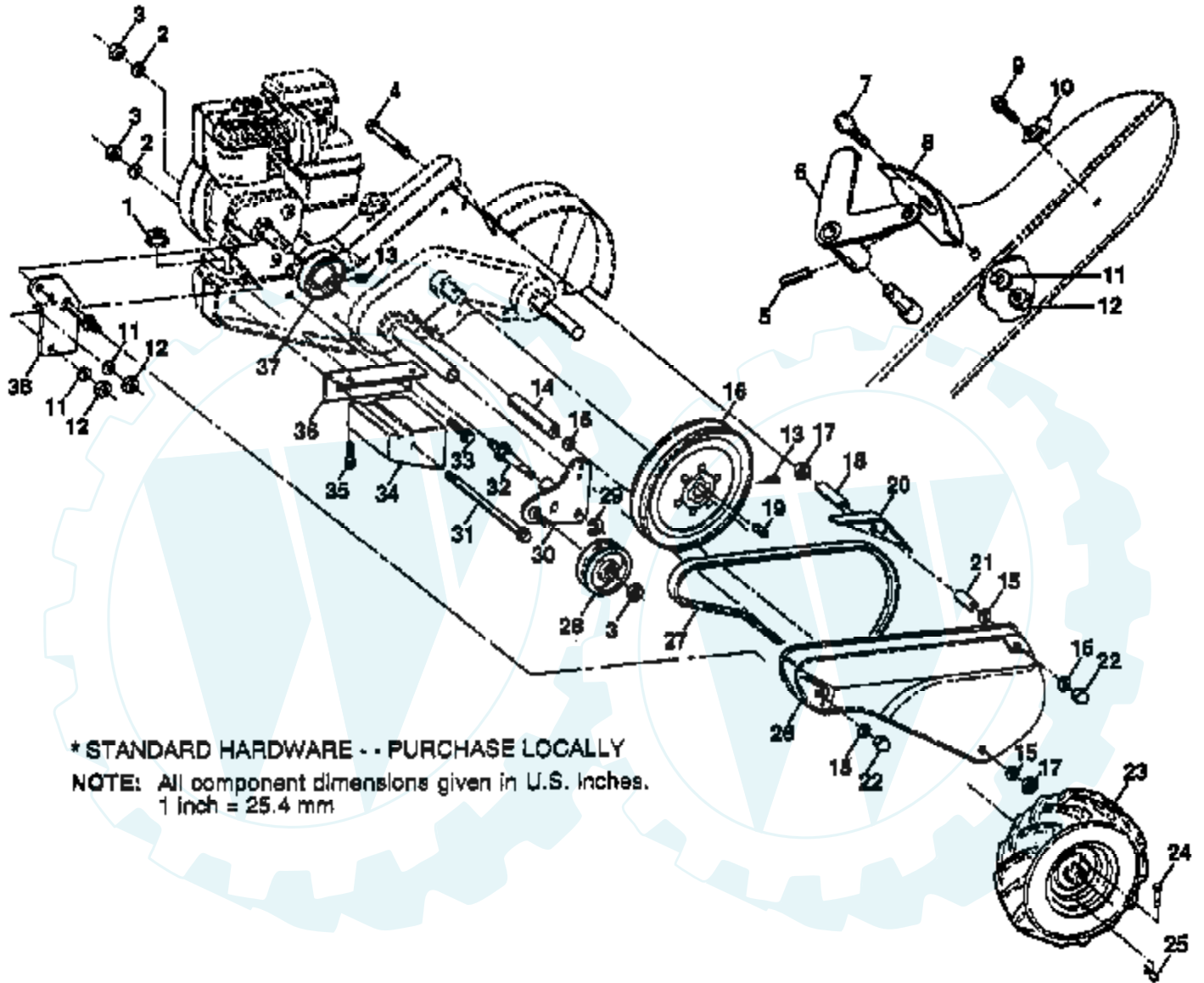

* STANDARD HARDWARE - - PURCHASE LOCALLY

NOTE: All component dimensions given in U.S. inches.
1 inch = 25.4 mm

Ref #	Part Number	Qty	Description
1	73510500		NUT
2	10040600		LOCKWASHER
3	73220600		NUT.HEX.3/8-16UNC
4	74930568		BOLT TI
5	1572H		SUB= 2882J
6	110111X		LEVER ASM CRT
7	72110404		BOLT
8	8700J		PANEL TI
9	86777		SUB= 750097
10	9484R		CONDIUT CLIP T
11	10040400		LOCKWASHER
12	73220400		SUB= 50675
13	23230506		SET SCREW
14	120938X		SPACER
15	19111116		WASHER
16	100473M		"SHEAVE 10"" CRT"
17	73220500		NUT.HEX.5/16-18
18	110651X		SPACER CRT
19	2649M		KEY T
20	110653X		GUARD CRT
21	131691		SPLIT SPACER
22	104214X		NUT TI
23	102190X		TIRE.CHV.13X5.0-6
	124258X		RIM
	795R		SUB= 65139
24	126875X		RIVET.DRILL.1.75
25	4497H		RETAINER M
26	131159X520		GUARD.BELT.
27	132672		BELT-V
28	104679X		PULLEY-IDLER TI
29	12000032		KLIP RING
30	105611X		SUB= 918105611X
31	102384X		BOLT CRT
32	102141X		SHIFT ARM CRT
33	74760616		BOLT
34	102383X		COUNTERWEIGHT CRT
35	74760524		BOLT.HEX.5/16-1.5
36	102331X		BRACKET LH CRT
37	130816		ENGINE SHEAVE
38	131558		BELT GUARD BRKT

5 HP 17" TILLER - - MODEL NUMBER 95220 (952201)

MAINFRAME, RIGHT SIDE

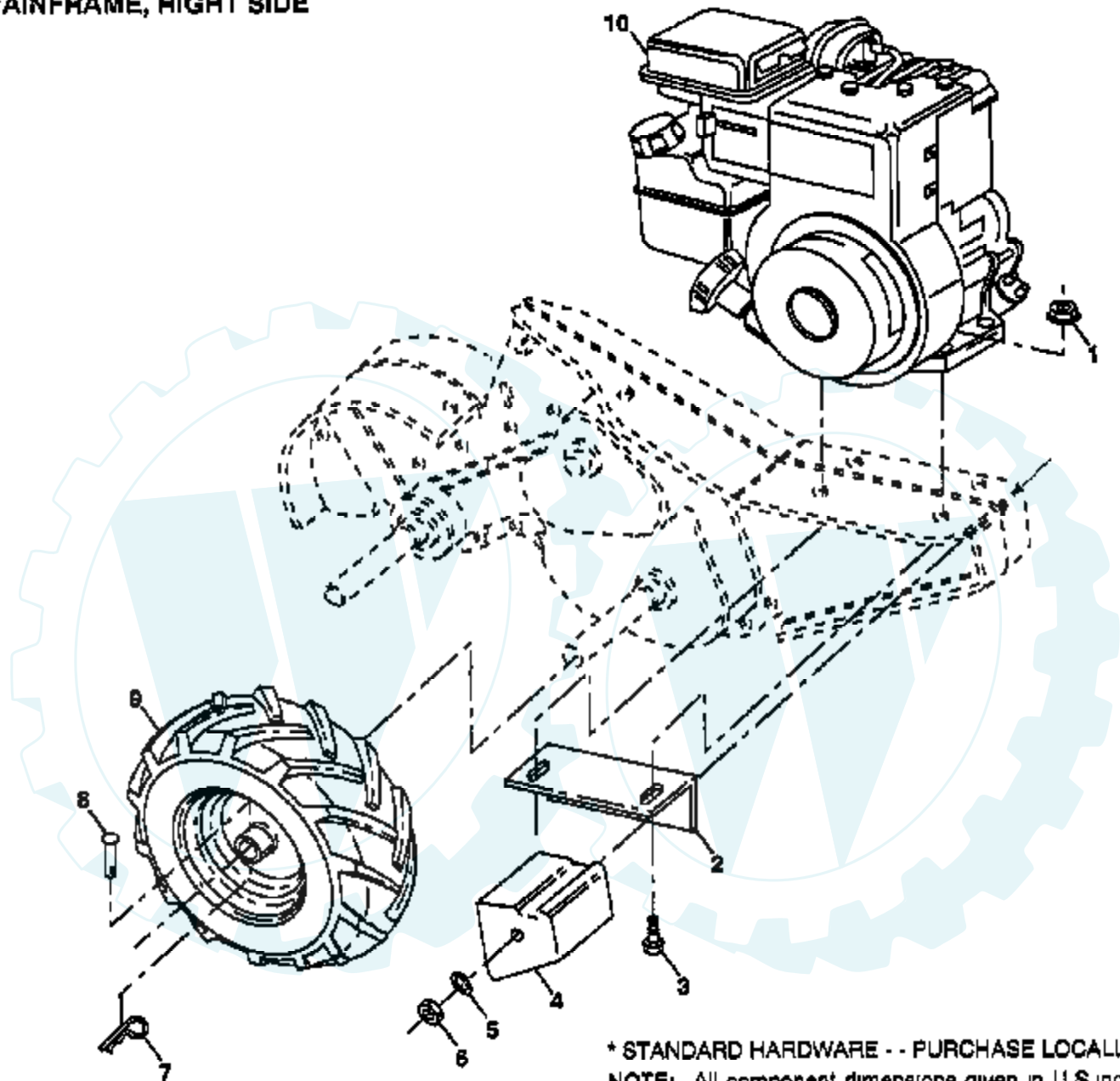

* STANDARD HARDWARE - - PURCHASE LOCALLY
NOTE: All component dimensions given in U.S.inches.
1 inch = 25.4 mm

Ref #	Part Number	Qty	Description
1	73510500		NUT
2	102332X		BRACKET RH CRT
3	74760524		BOLT.HEX.5/16-1.5
4	102173X		COUNTERWEIGHT CRT
5	10040600		LOCKWASHER
6	73220600		NUT.HEX.3/8-16UNC
7	4497H		RETAINER M
8	126875X		RIVET.DRILL.1.75
9	102190X		TIRE.CHV.13X5.0-6
	124258X		RIM
	795R		SUB= 65139
10			REFER TO IMAGE



5 HP 17" TILLER - - MODEL NUMBER 95220 (952201)

TINE ASSEMBLY

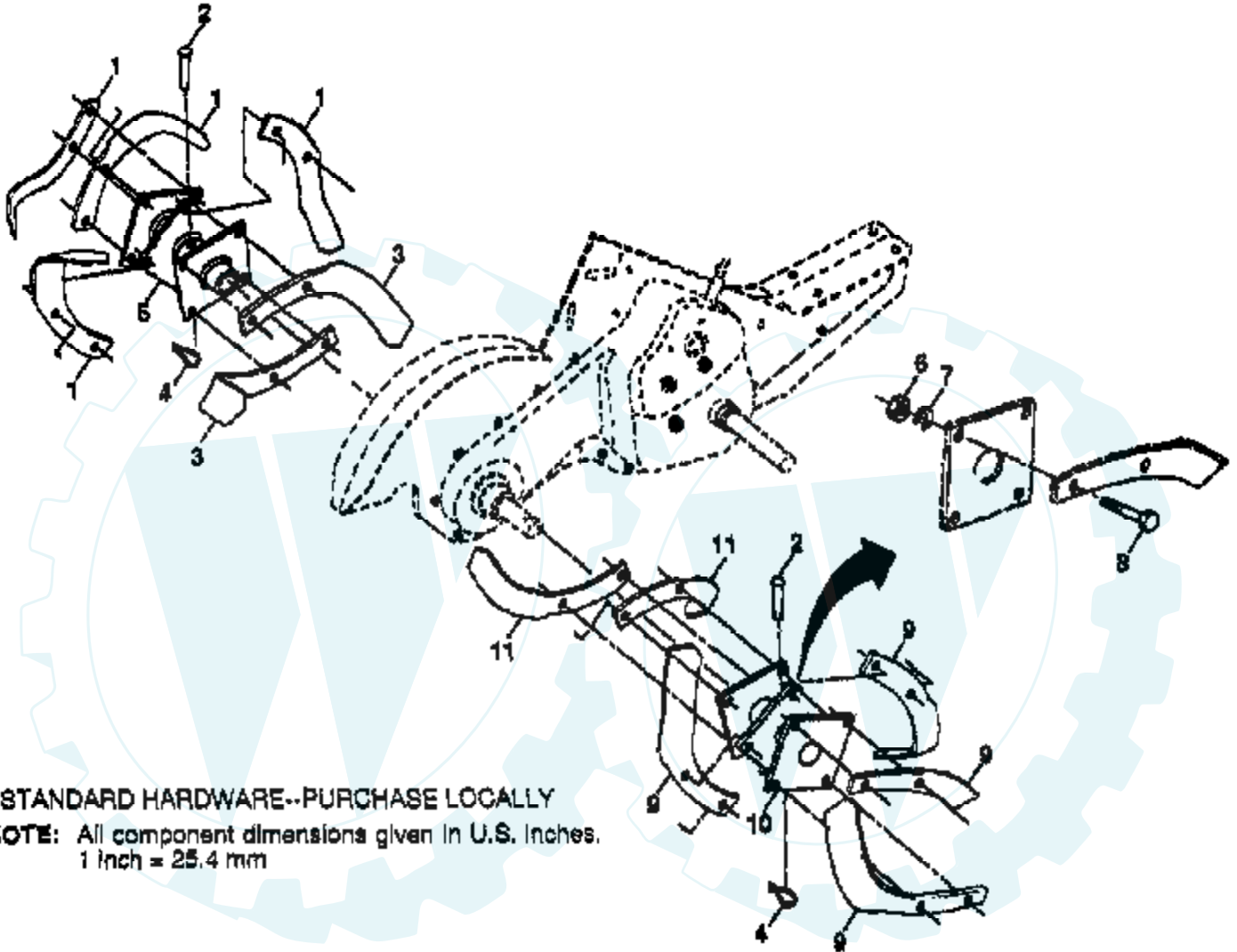

* STANDARD HARDWARE--PURCHASE LOCALLY

NOTE: All component dimensions given in U.S. inches.
1 inch = 25.4 mm

Ref #	Part Number	Qty	Description
1	4459J		SUB= 6554J
2	132673		PIN.CLEVIS.SHEAR
3	6554J		"TINE.LH.12""
4	3146R		RETAINER.SPRING
5	132727		HUB&PLATE ASM LH
6	73610600		SUB= 7810H
7	10040600		LOCKWASHER
8	74610616		BOLT
9	4460J		SUB= 6555J
10	132728		HUB&PLATE ASM RH
11	6555J		"TINE.RH.12""



5 HP 17" TILLER - - MODEL NUMBER 95220 (952201)

TINE SHIELD

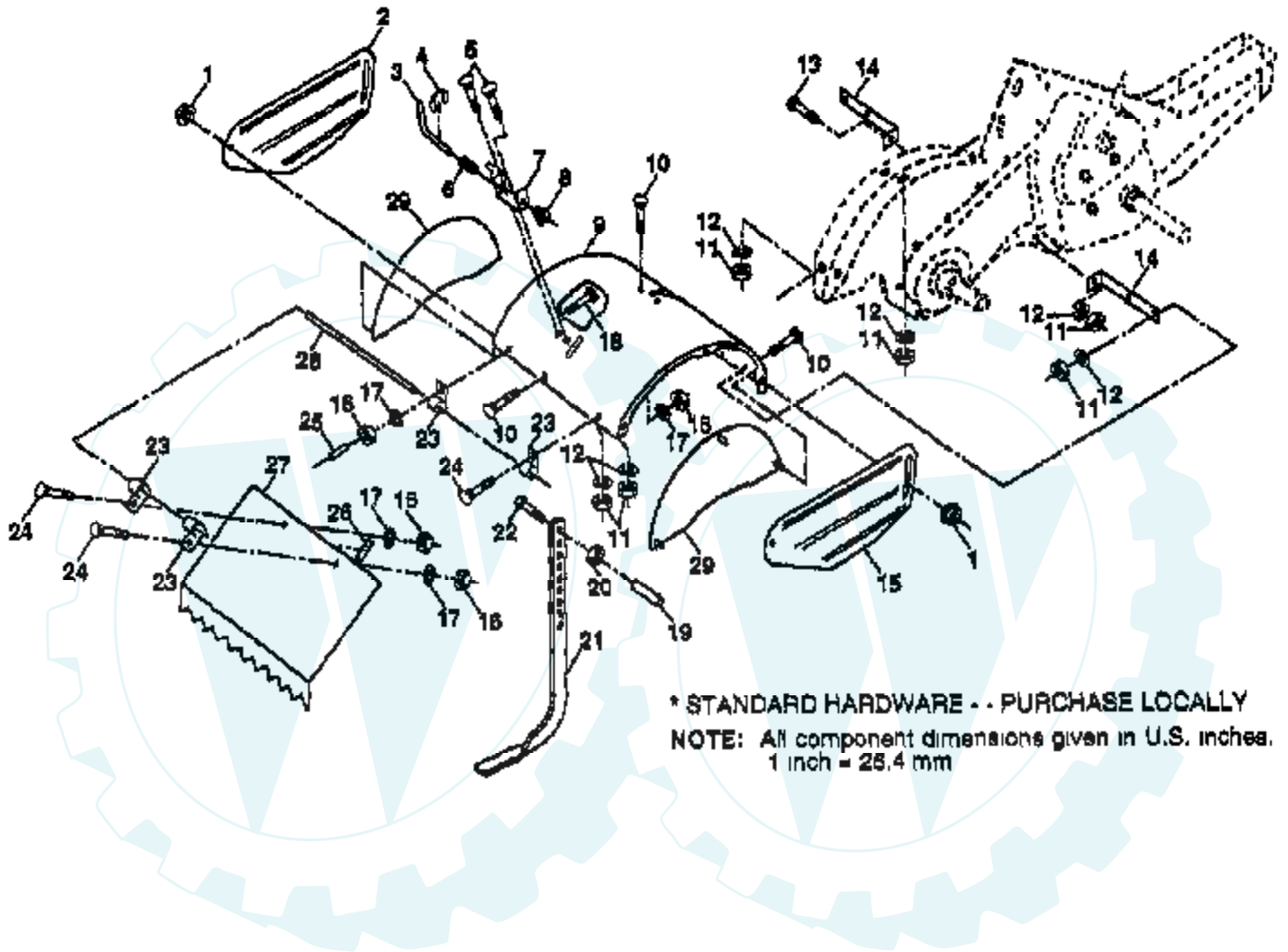

* STANDARD HARDWARE - - PURCHASE LOCALLY
NOTE: All component dimensions given in U.S. inches.
1 inch = 25.4 mm

Ref #	Part Number	Qty	Description
1	98000129		NUT
2	104086X520		SHIELD.SD.OUT.LH
3	8393J		STAKE PIN TI
4	12000036		KLIP RING TI
5	72110508		BOLT CRT
6	8394J		SPRING TI
7	8392J		LATCH BRACKET TI
8	109230X		SPRING CRT
9	102326X520		SHIELD.TINE
10	72140506		BOLT
11	73220500		NUT.HEX.5/16-18
12	10040500		LOCKWASHER
13	72110510		BOLT
14	124343X		BRKT SHIELD TINE
15	104101X520		SHIELD.SD.OUT.RH
16	73220400		SUB= 50675
17	10040400		LOCKWASHER
18	72040410		BOLT
19	102701X		GRIP CRT
20	73220600		NUT.HEX.3/8-16UNC
21	102156X		SUB= 102156X500
22	74930632		BOLT
23	4440J		HINGE CRT
24	72140404		BOLT
25	6712J		VINYL CAP TI
26	109227X		PAD IDLER TI
27	102695X520		SHIELD.LEVELING
28	120588X		PIN HINGE
29	104085X520		SHIELD.SIDE

5 HP 17" TILLER - - MODEL NUMBER 95220 (952201)

TRANSMISSION

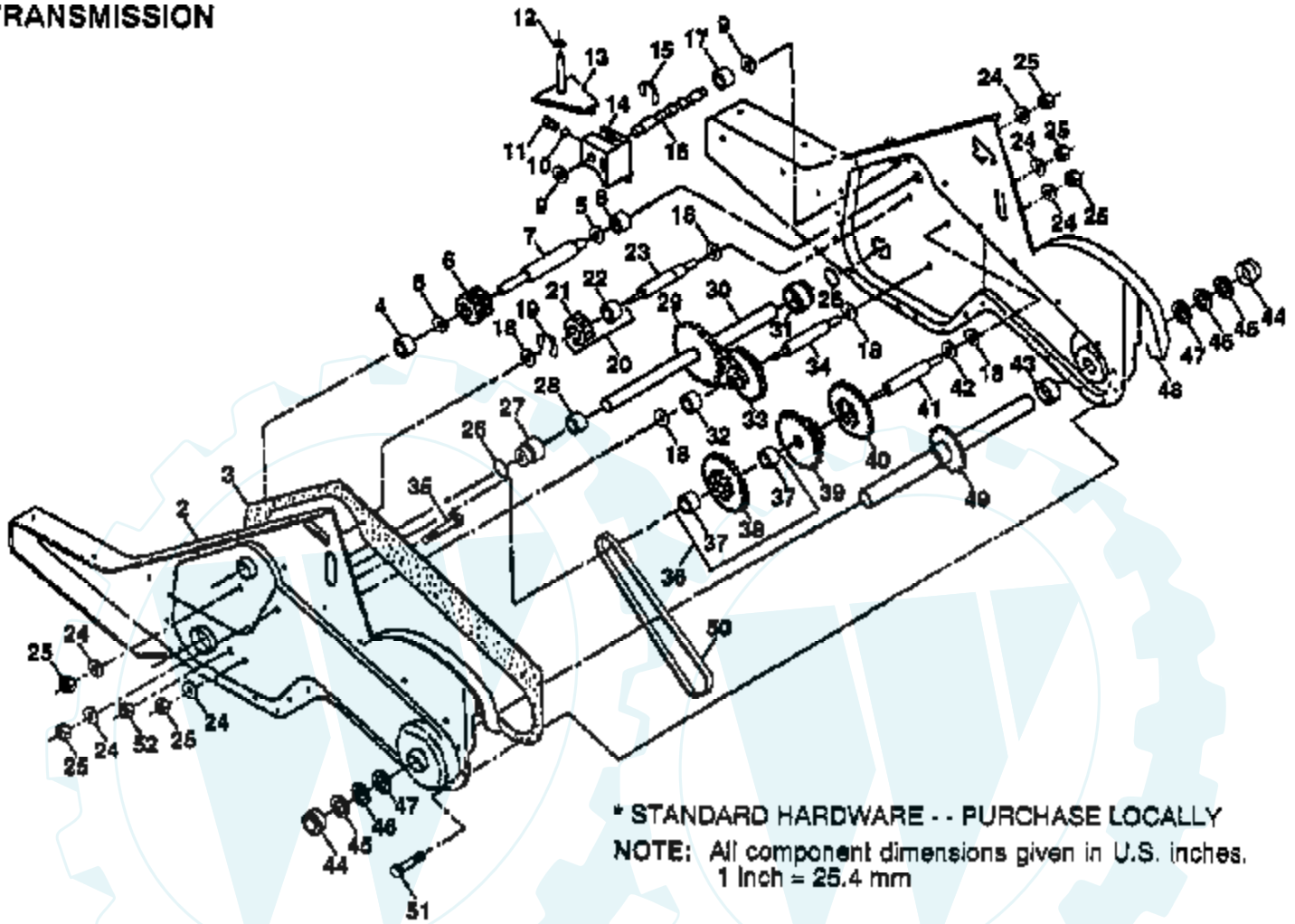

Ref #	Part Number	Qty	Description
1	137555		SUB= 155112
2	121147X		SUB= 150698
3	106211X		GASKET TI
4	5020J		NEEDLE BRNG LT
5	1370H		"T, BEARING"
6	102113X		PINION-INPUT CRT
7	102110X		SHAFT-INPUT CRT
8	4895H		"TI, BEARING"
9	102136X		WASHER SEAL CRT
10	7392M		SUB= 100482K
11	100371K		SPRING-SHIFT CRT
12	106160X		O-RING TI
13	102107X		ARM ASSY CRT
14	8353J		SHIFT FORK TI
15	12000039		KLIP RING
16	102109X		SHAFT SHIFT CRT
17	104159X		SPACER SPLIT CRT
18	4358J		WASHER
19	12000040		KLIP RING
20	102114X		GEAR ASSY CRT
21	102115X		GEAR-REV IDLR CRT
22	6803J		NEEDLE BEARING TI
23	102111X		SHAFT CRT
24	10040700		LOCKWASHER
25	73610700		NUT.ASF.HEX.7/16
26	102128X		O RING CRT
27	102100X		"CRT, BEARING"
28	106390X		BUSHING TI
29	102134X		CHAIN CRT
30	109204X		SUB= 150737
31	102106X		SUB= 918102106X
32	106388X		SPACER TI
33	102121X		SPRCKT 8 GEAR CRT
34	102112X		SHFT 2ND RED. CRT
35	102101X		SCRW WHIZ LOK CRT
36	137300		SPROCKET ASM.
37	4422J		BEARING
38	137301		SUB= 137300
39	105345X		GEAR TI
40	105346X		GEAR TI
41	8358J		REDUCTION SHFT TI
42	4220R		BRNG RACE
43	106146X		SPACER TI
44	9672R		CUP.FORMED.
45	102144X		RING SPIRAL CRT
46	9676R		SUB= 147344
47	9674R		SUB= 147344
48	121745X		SUB= 150700
49	132688		TINE SHAFT
50	106147X		CHAIN.50 LINK TI
51	17580408		SCREW CRT
52	73220500		NUT.HEX.5/16-18
	6066J		GREASE PREMIUM-1