

10 HP 36" TRACTOR - - MODEL NUMBER Y10L36A BRAKE / REAR MOWER LIFT ASSEMBLY

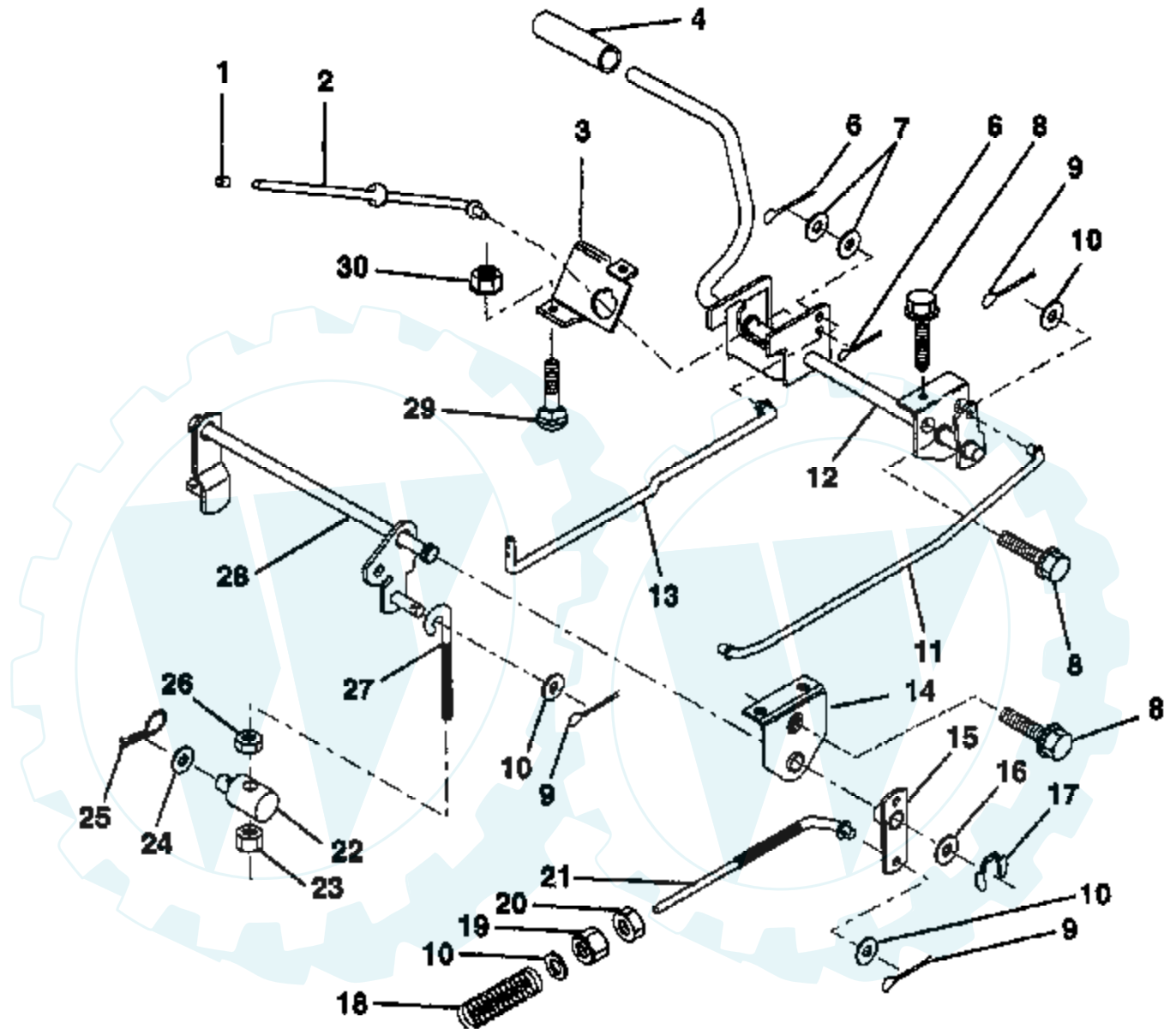

* STANDARD HARDWARE - - PURCHASE LOCALLY
NOTE: All component dimensions given in U.S. inches
1 inch = 25.4 mm

Ref #	Part Number	Qty	Description
1	71673		PLUNGER CAP T
2	123436X		"ROD,PARK BRAKE"
3	123437X		"BRKT,PARK BRAKE"
4	8156H		FOOT PEDAL COVER
5	122504X		"BRKT,CLU PEDAL LH"
6	76020312		SUB= 3145
7	19131016		WASHER
8	17490508		SCREW LT
9	76020412		COTTER PIN
10	19131316		WASHER
11	123543X		"ROD,FRT BRAKE"
12	129567		SUB= 139933
13	123394X		"ROD,CLUTCH"
14	121978X		"BRKT,LIFT SHAFT"
15	123641X		BRAKE PIVOT ARM
16	19251816		WASHER T
17	12000034		KLIP RING
18	106888X		SPRING ROD LT
19	73680600		SUB= 73690600
20	73350600		NUT
21	131460		SUB= 532131460
22	127378		SUB= 144585
23	73680600		SUB= 73690600
24	19132012		WASHER
25	4921H		SPRING.RETAINER
26	73930600		LOCKNUT
27	127369		"LINK, MOWER REAR"
28	127358		SUB= 140776
29	72110506		SUB= 72270506
30	73510500		NUT

10 HP 36" TRACTOR -- MODEL NUMBER Y10L36A

DASH

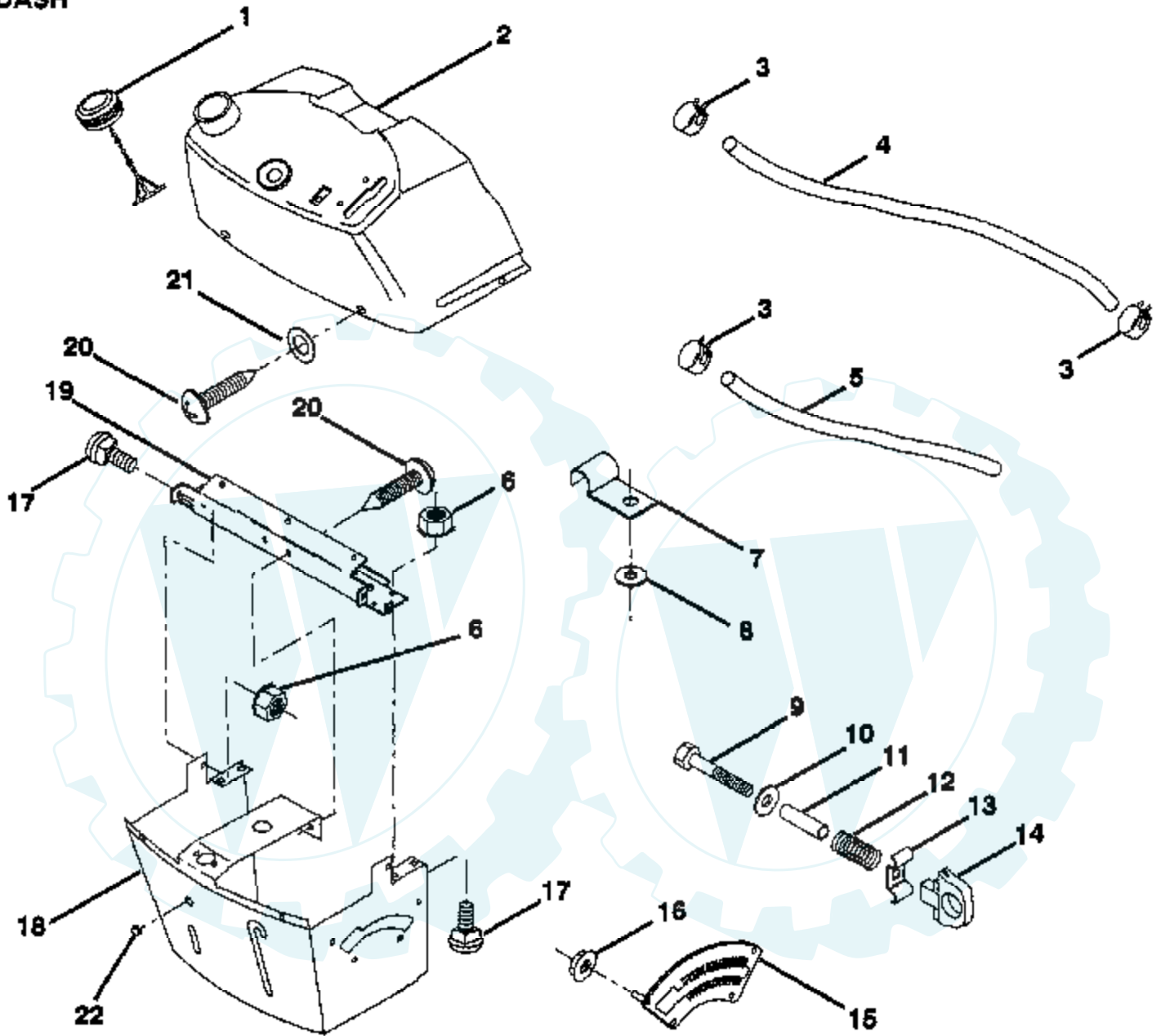

* STANDARD HARDWARE -- PURCHASE LOCALLY
NOTE: All component dimensions given in U.S. inches.
1 inch = 25.4 mm

Ref #	Part Number	Qty	Description
1	122015X		SUB= 141523
2	130913		SUB= 138393
3	123487X		HOSE CLAMP
4	8544R		SUB= 295J
5	8548R		FUEL LINE T
6	73510400		NUT
7	2751R		CLIP T
8	19091216		WASHER PM
9	74760428		BOLT
10	19091413		WASHER
11	121249X		SPACER SPLIT
12	3720R		SPRING M
13	126450X		"KNOB,HGT RETAINER"
14	126115X		KNOB
15	122023X		ADJUSTER QUAD
16	124346X		NUT
17	72110404		BOLT
18	130745		SUPT ASSY DASH
19	134744		CROSS BRACE
20	18000408		SUB= 818000408
21	19090816		WASHER
22	134014		PLUG DOME

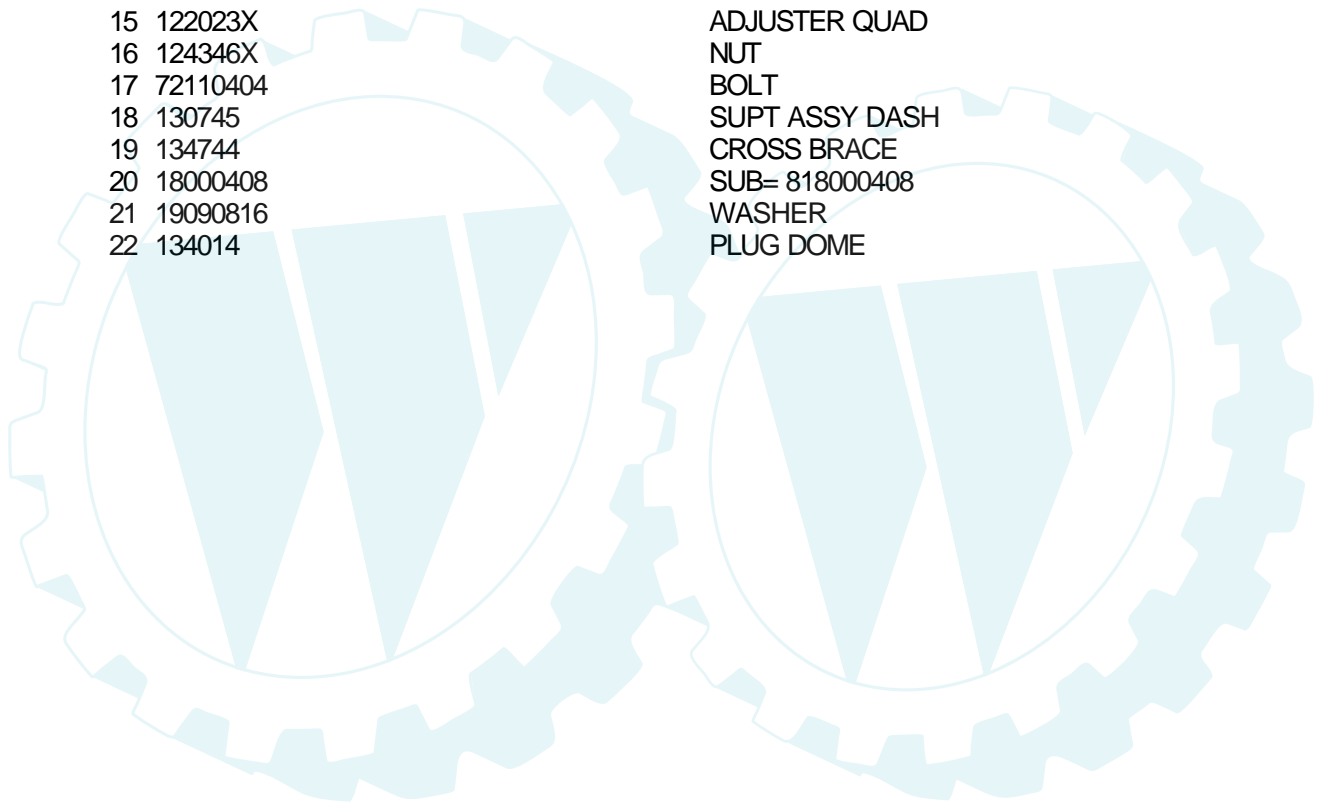

10 HP 36" TRACTOR - - MODEL NUMBER Y10L36A

DECALS

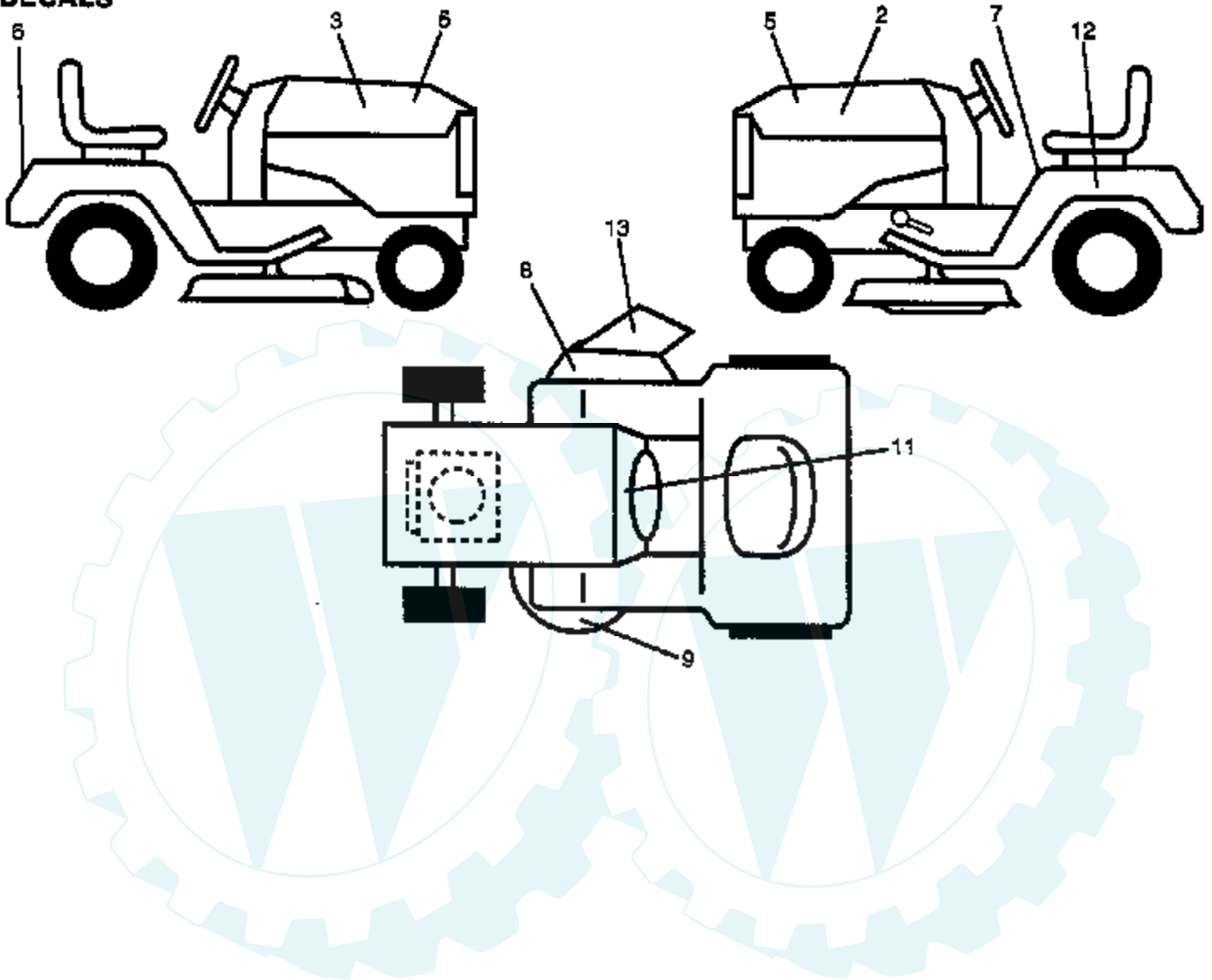

Ref #	Part Number	Qty	Description
2	122036X		NLA
3	122037X		NLA
5	127192		DECAL
6	123689X		NLA
7	133795		DECAL CAUTION
8	123658X		DECAL WARNING
9	109820X		DECAL YT
11	123637X		SUB= 138269
12	121549X		DECAL
13	123649X		DECAL WARNING
	133626		OPERATORS MANUAL
	131745		OP MANUAL
	136047		MANUAL



10 HP 36" TRACTOR - - MODEL NUMBER Y10L36A

ELECTRICAL

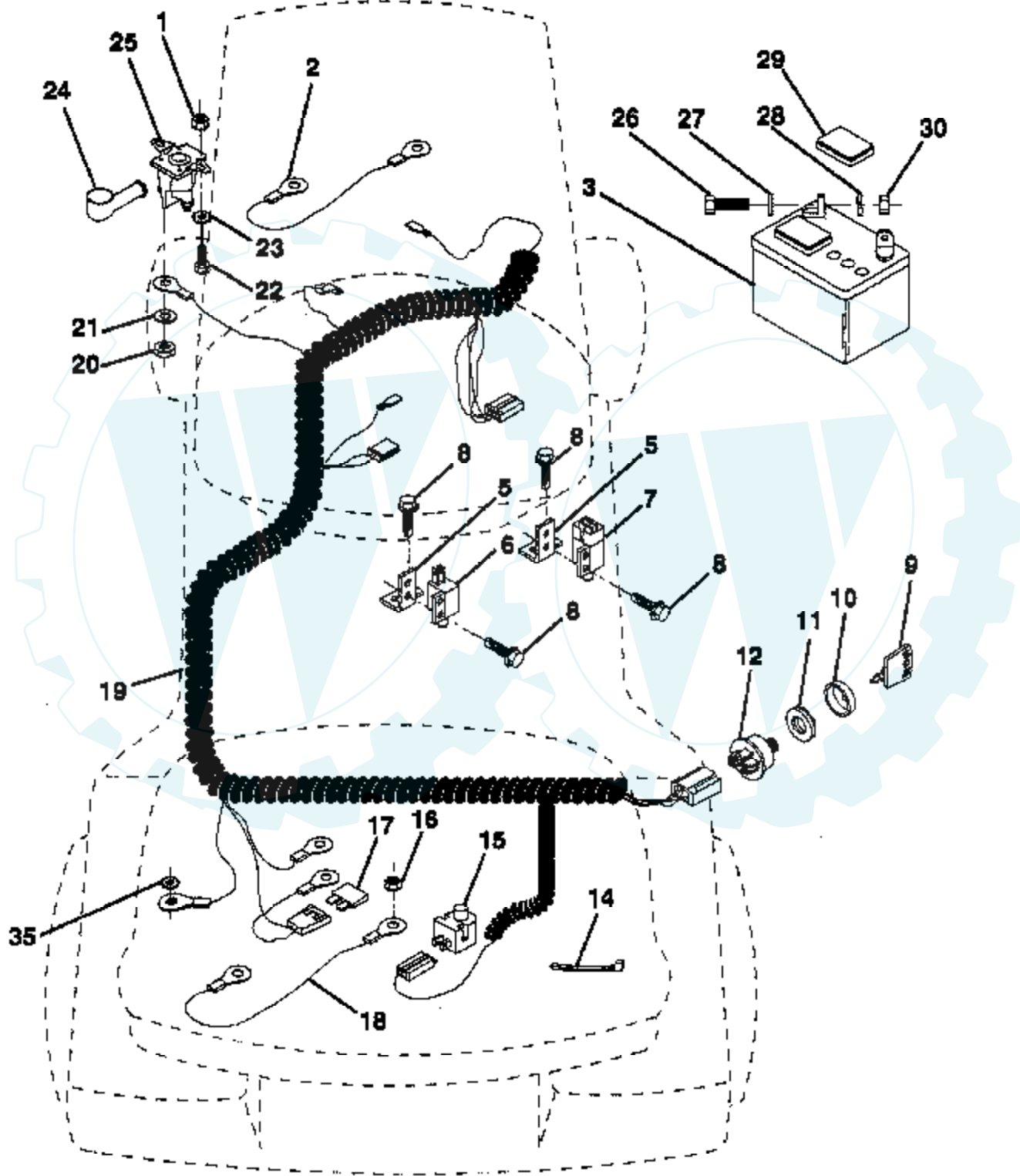

Ref #	Part Number	Qty	Description
1	73510400		NUT
2	108423X		CABLE ASM.
3	133909		SUB= 123899X
5	108236X		BRACKET LT
6	104445X		SWITCH-INTER. GT
7	109553X		SWITCH INTERLOCKT
8	17021008		SCREW
9	7552H		SUB= STD365410
10	123620X		SUB= 141226
11	124211X		NUT IGNITION
12	4406R		SUB= STD365402
14	7192J		WIRE TIE
15	121305X		SWITCH SEAT
16	73510500		NUT
17	108824X		FUSE HYT
18	128353		CABLE ASSY
19	132223		SUB= 532132223
20	73350400		NUT
21	10090400		SUB= 10040400
22	74780408		BOLT
23	11050400		LOCKWASHER
24	131563		SUB= 154336
25	109081X		SUB= 146154
26	74760412		BOLT LT
27	19091016		WASHER
28	10040400		LOCKWASHER
29	121264X		"CAP,BATTERY "
30	73220400		SUB= 50675
35	11050600		LOCKWASHER

10 HP 36" TRACTOR -- MODEL NUMBER Y10L36A ENGINE / THROTTLE

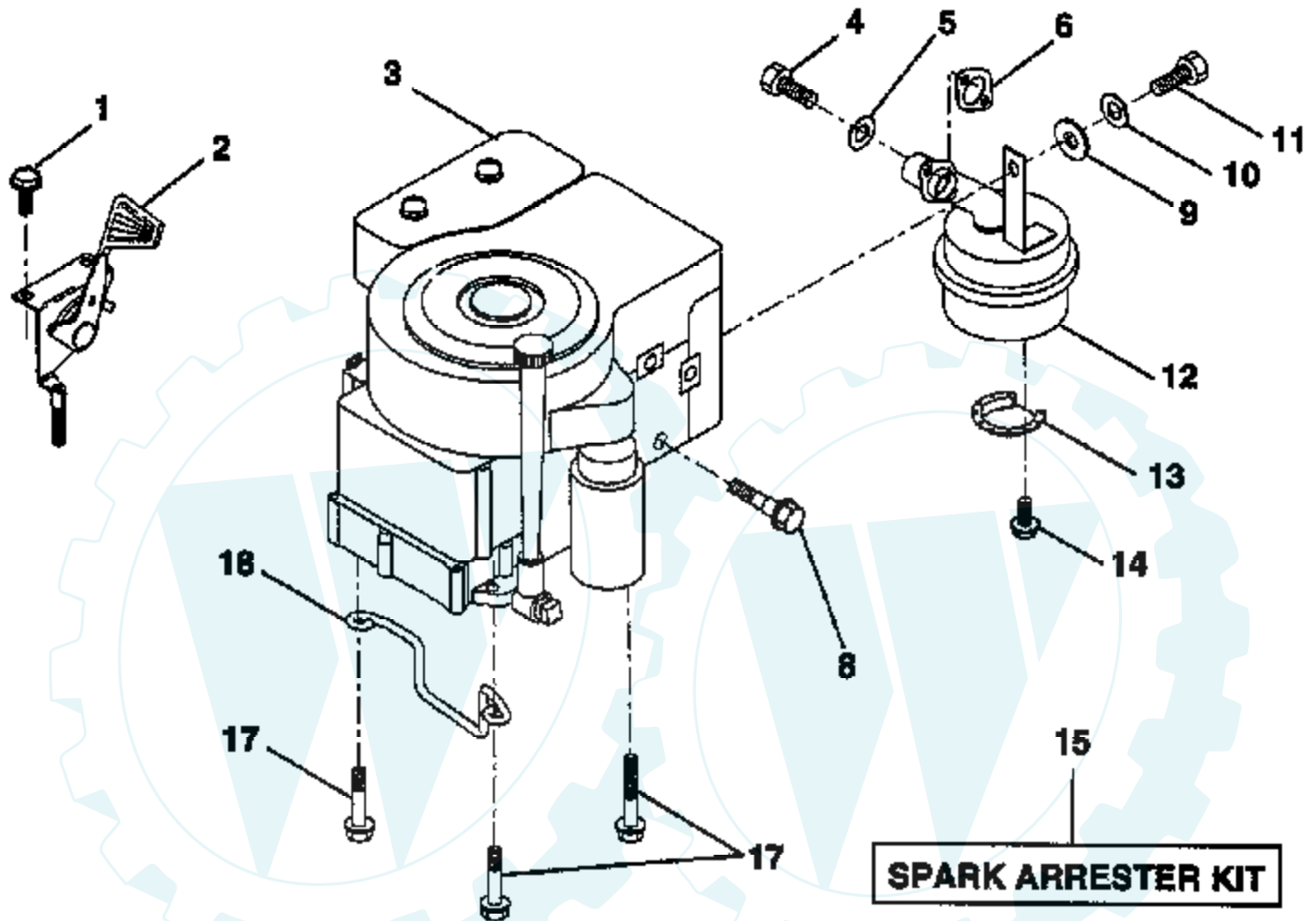

* STANDARD HARDWARE -- PURCHASE LOCALLY
NOTE: All component dimensions given in U.S. inches
1 inch = 25.4 mm

Ref #	Part Number	Qty	Description
1	17720408		SCREW
2	132521		THROTTLE CONTROL
3	286707		ENGINE
4	71070512		SCREW
5	10040500		LOCKWASHER
6	125593X		SUB= 272293
8	121094X		BOLT T
9	19101216		WASHER
10	10040400		LOCKWASHER
11	74780412		SUB= 74780414
12	124097X		MUFFLER
13	101326L		DEFLECTOR.222573
14	17030808		SUB= 17030814
15	121851X		SUB= 532137180
17	17490624		SCREW LT
18	126636X		"KEEPER,DR BELT GR"

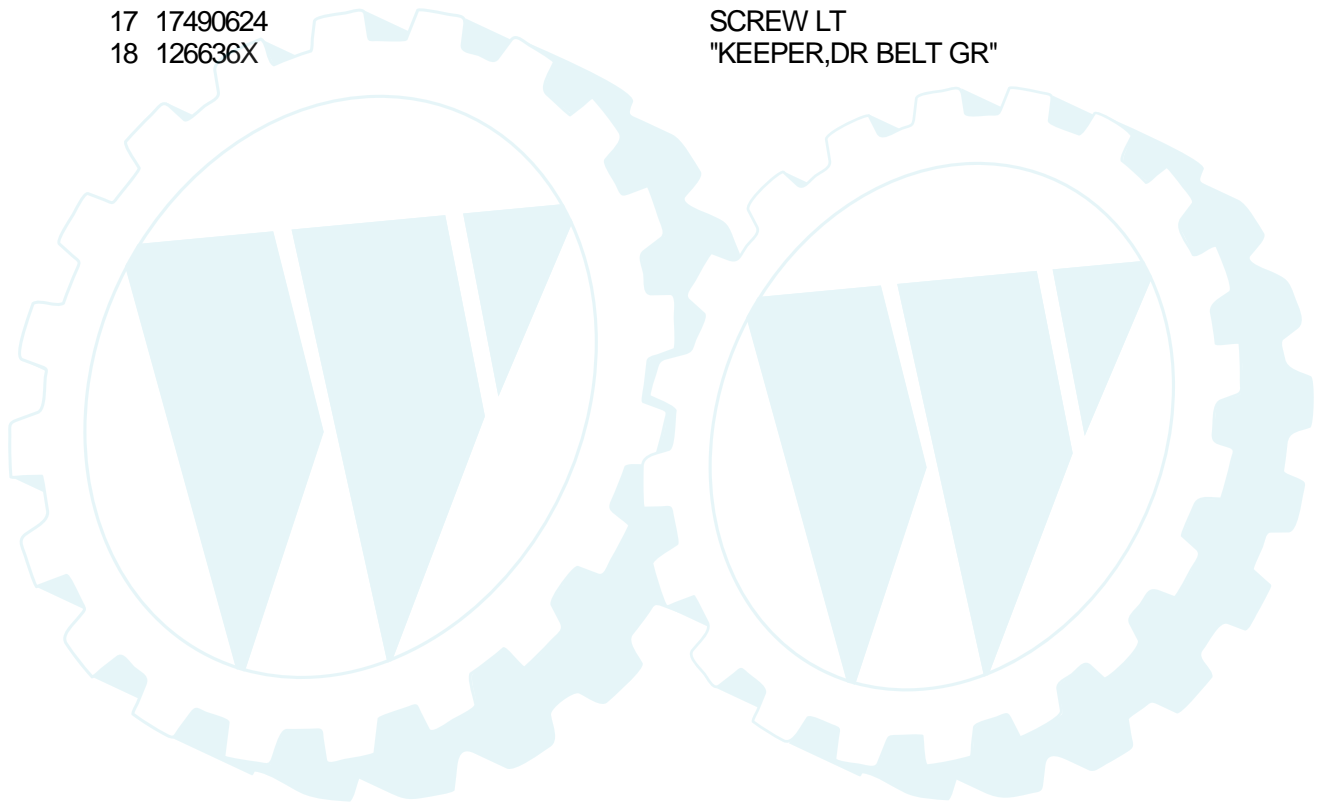

10 HP 36" TRACTOR - - MODEL NUMBER Y10L36A

FENDER / CHASSIS

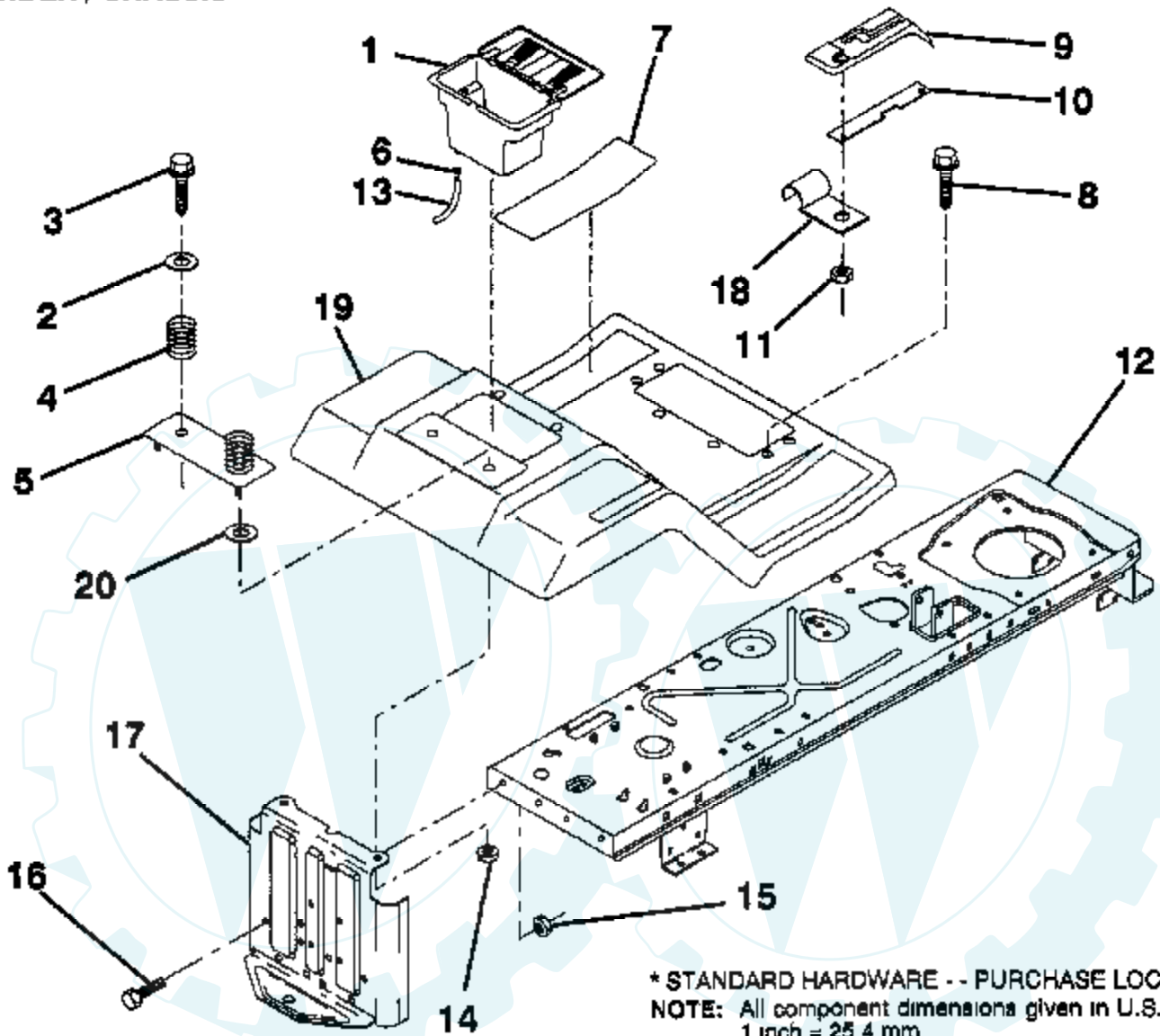

* STANDARD HARDWARE - - PURCHASE LOCALLY
NOTE: All component dimensions given in U.S. inches.
1 inch = 25.4 mm

Ref #	Part Number	Qty	Description
1	129965		SUB= 156417
2	19132012		WASHER
3	17490612		SCREW
4	124181X		SPRING COMPRESSIO
5	127115X505		BTRY FENDER PLATE
6	109596X		HOSE CLAMP T
7	124144X		PAD FOOTREST
8	17490512		SCREW
9	126993X		CONSOLE SHFT 4SP
10	124602X		SUB= 139783
11	124346X		NUT
12	133384		SUB= 139893
13	105687X		SUB= 109238X
14	73510400		NUT
15	73680500		SUB= 73690500
16	74760512		BOLT
17	127880		DRAWBAR
18	126470X		"CLIP,INSULATOR"
19	128083X505		SUB= 140955X505
20	19091413		WASHER

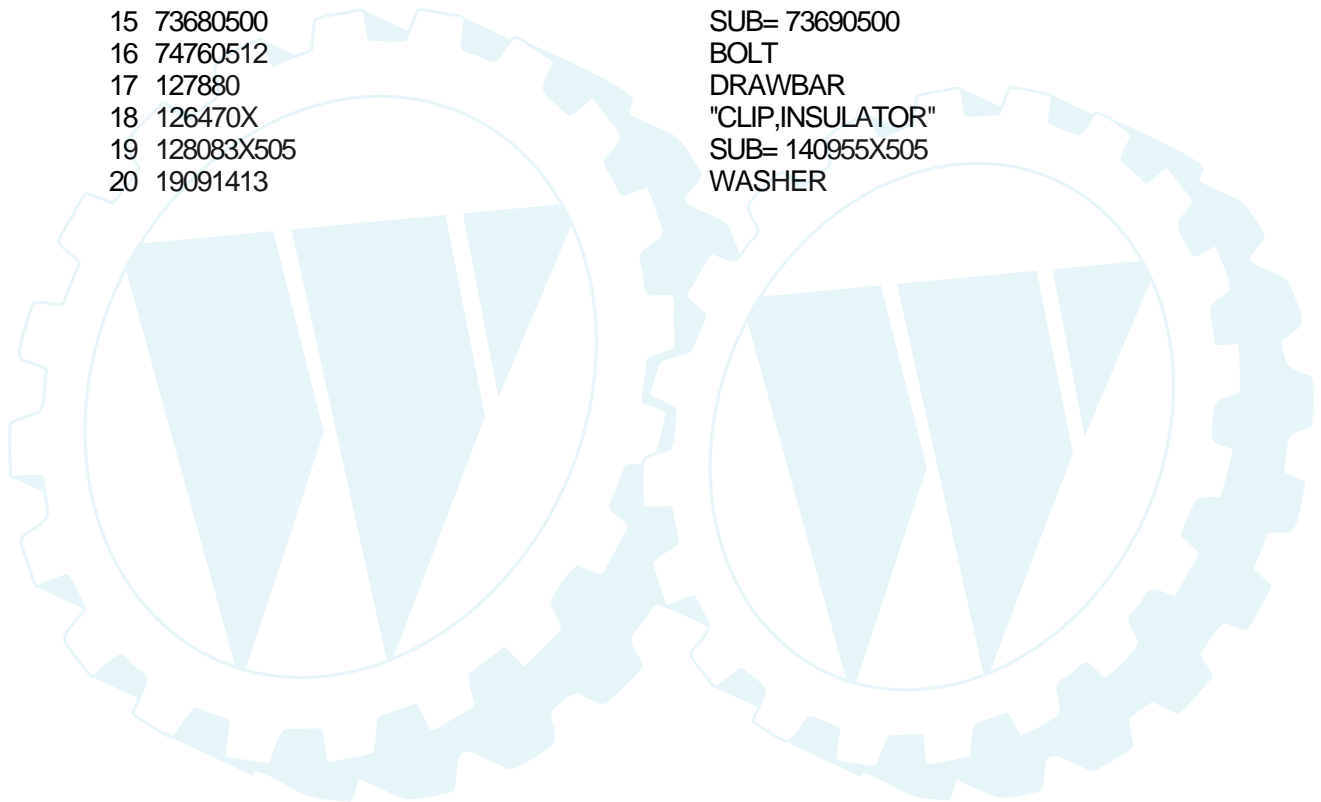

10 HP 36" TRACTOR - - MODEL NUMBER Y10L36A

FRONT AXLE

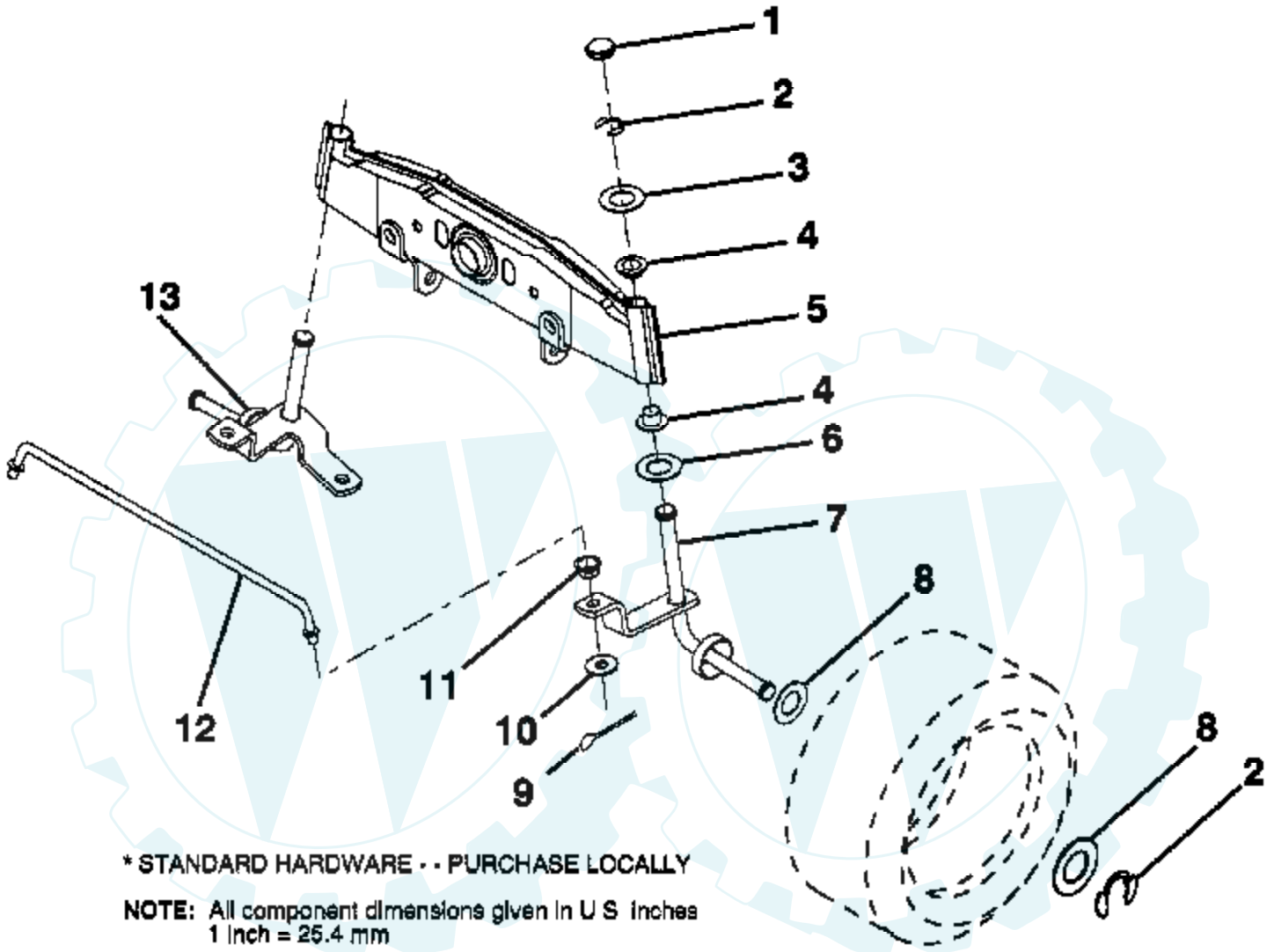

Ref #	Part Number	Qty	Description
1	121232X		CAP
2	12000029		RING
3	121748X		WASHER
4	121922X		NYLINER
5	121914X		AXLE FRONT
6	6266H		WASHER .T
7	121919X		SPINDLE RH
8	121749X		WASHER
9	76020412		COTTER PIN
10	19131316		WASHER
11	126847X		BUSHING.DRAGLINK
12	121924X		ROD TIE
13	121916X		SPINDLE LH



10 HP 36" TRACTOR - - MODEL NUMBER Y10L36A

GROUND DRIVE

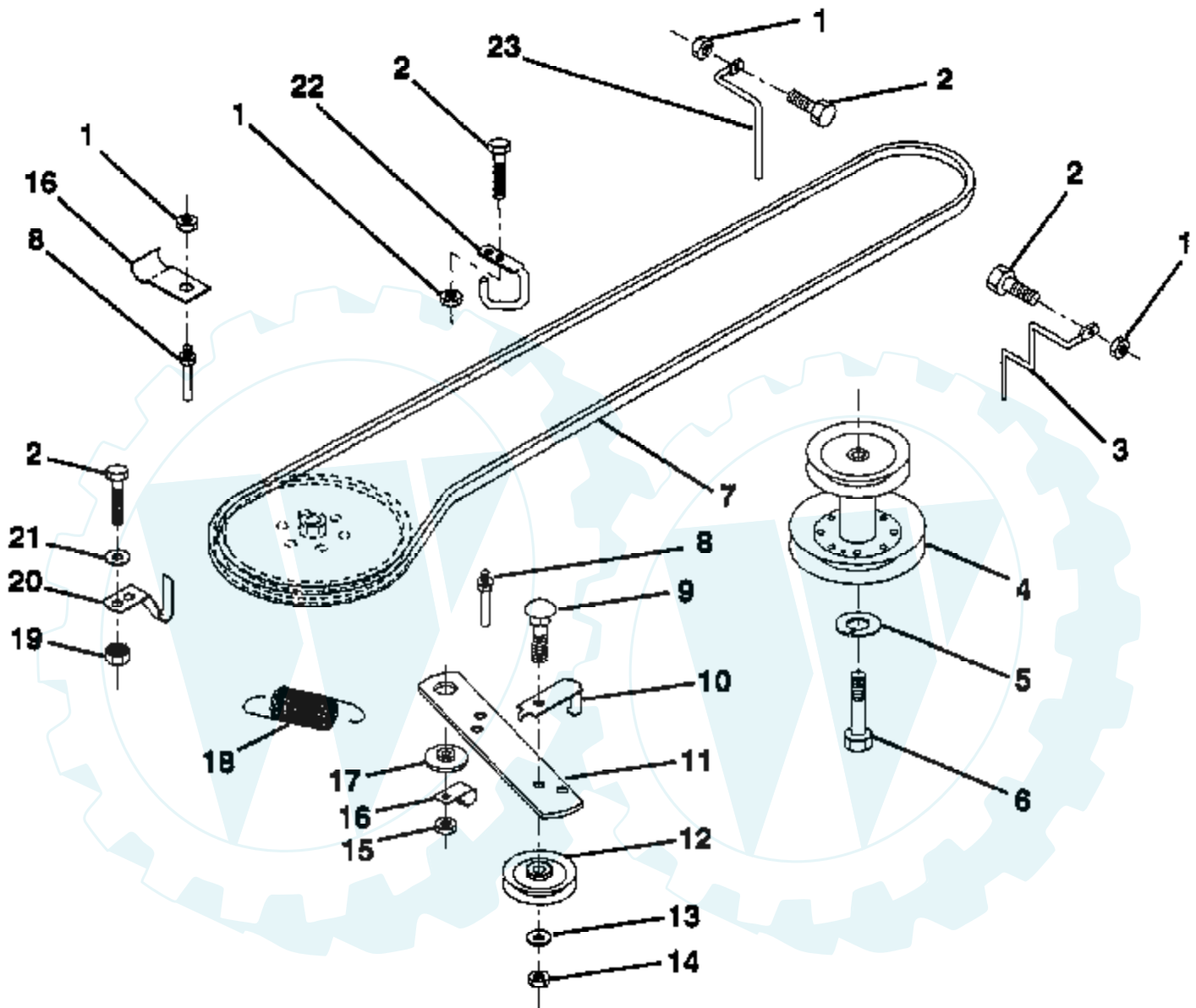

* STANDARD HARDWARE - - PURCHASE LOCALLY
NOTE: All component dimensions given in U.S. inches
1 inch = 25.4 mm

Ref #	Part Number	Qty	Description
1	73680500		SUB= 73690500
2	74760512		BOLT
3	131205		SUB= 532131205
4	134828		SUB= 138029
5	10040700		LOCKWASHER
6	71170744		HEX BOLT
7	124525X		BELT
8	123405X		"KEEPER,DRIVE BELT"
9	72140612		BOLT
10	123396X		"KEEP,IDLER DR BEL "
11	123395X		SUB= 140911
12	4859J		SUB= 123674X
13	19131316		WASHER
14	73930600		LOCKNUT
15	73680600		SUB= 73690600
16	126471X		"CLIP,INSULATOR"
17	122052X		SPACER RETAINER
18	131459		SUB= 532131459
19	73510500		NUT
20	123891X		"KEEPER,DR BELT "
21	19111016		WASHER
22	123404X		"KEEPER,FRA DR BEL "
23	131204		SUB= 532131204

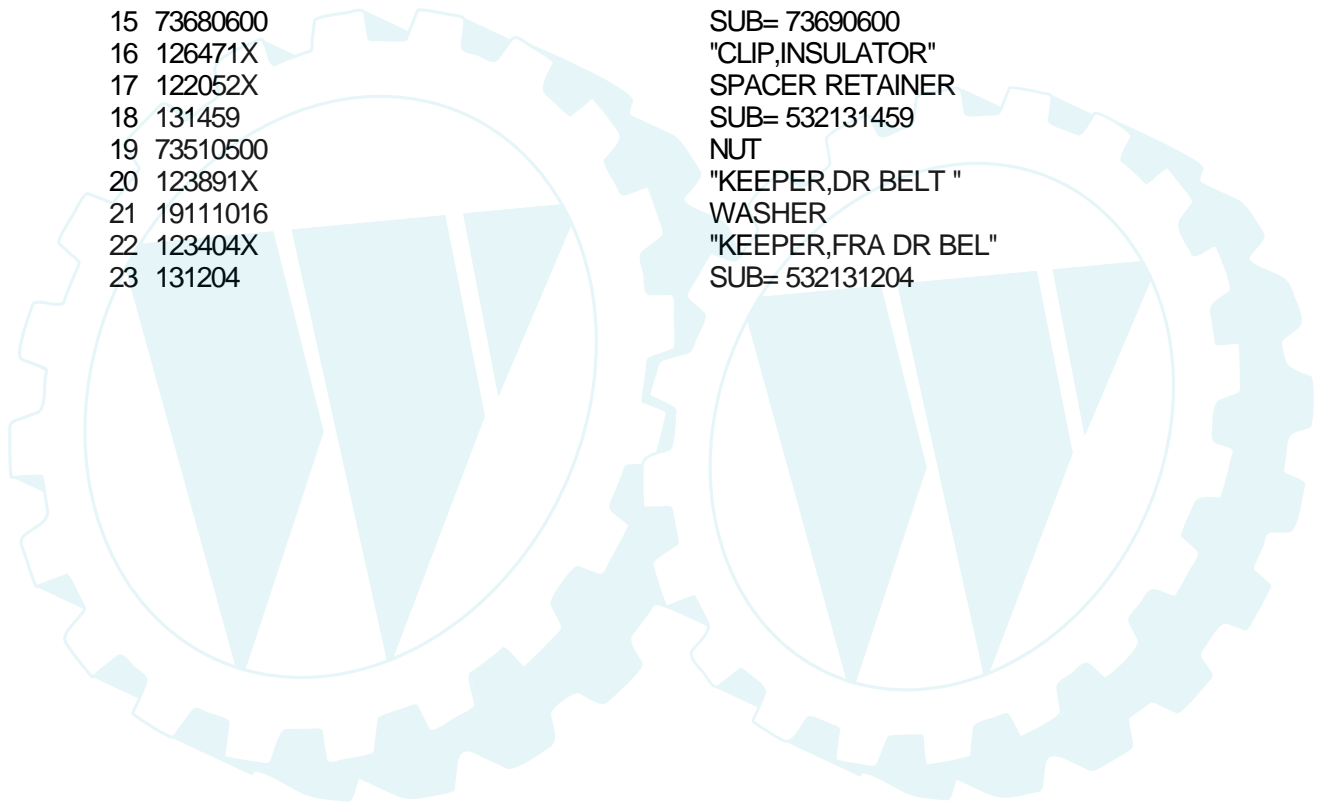

10 HP 36" TRACTOR - - MODEL NUMBER Y10L36A

HOOD

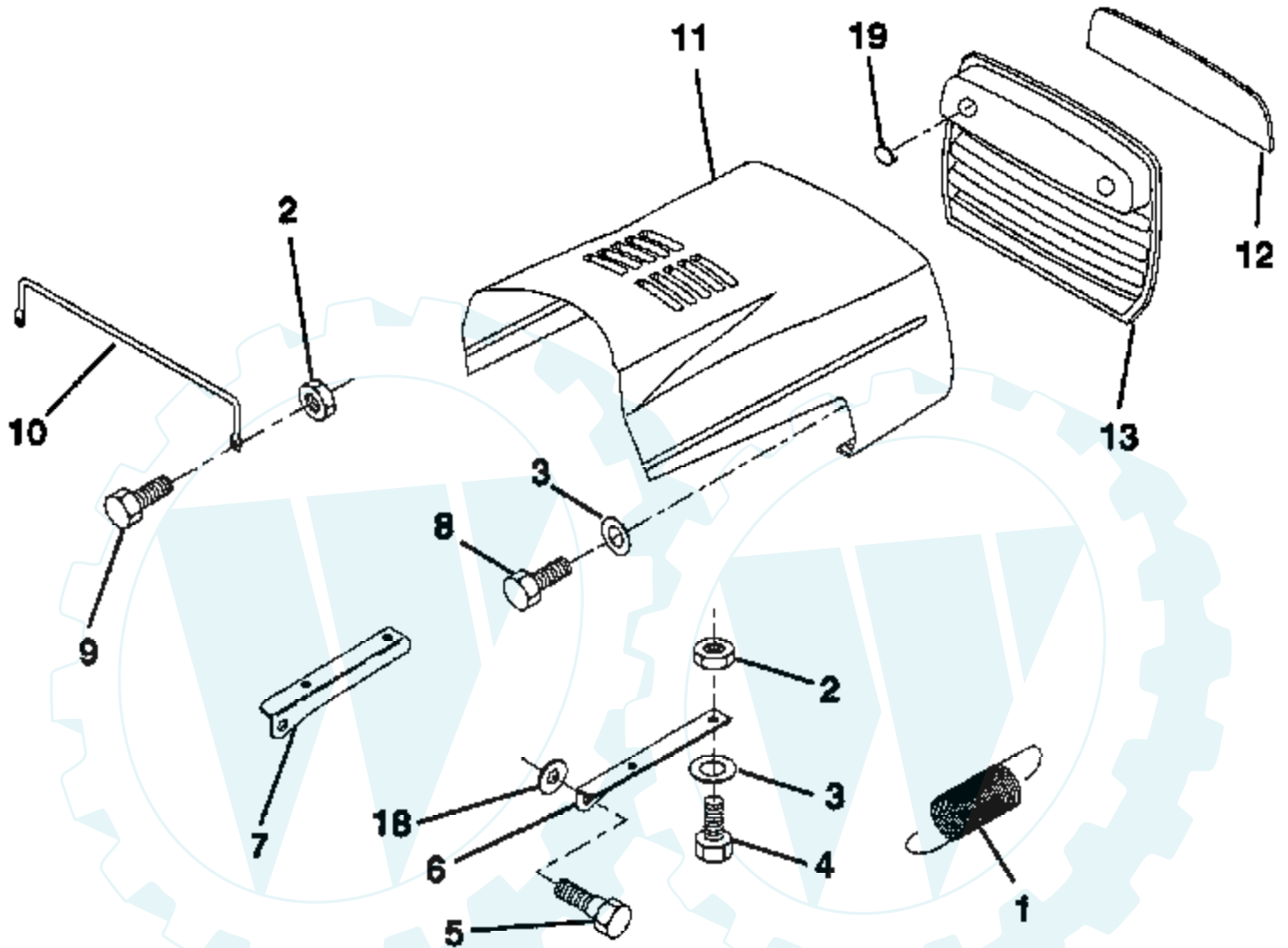

* STANDARD HARDWARE - - PURCHASE LOCALLY

NOTE: All component dimensions given in U.S. inches.
1 inch = 25.4 mm

Ref #	Part Number	Qty	Description
1	124657X		EXT SPRING
2	73510400		NUT
3	19091016		WASHER
4	74780410		BOLT
5	126675X		SUB= 139888
6	122549X		BRKT HOOD RH
7	122548X		BRKT HOOD LH
8	17411310		SUB= 17521312
9	74780412		SUB= 74780414
10	123693X		"BRACE,HOOD"
11	132918X505		HOOD
12	122035X		LENS
13	127029X		GRILL
18	19111116		WASHER
19	131319		SUB= 532131319

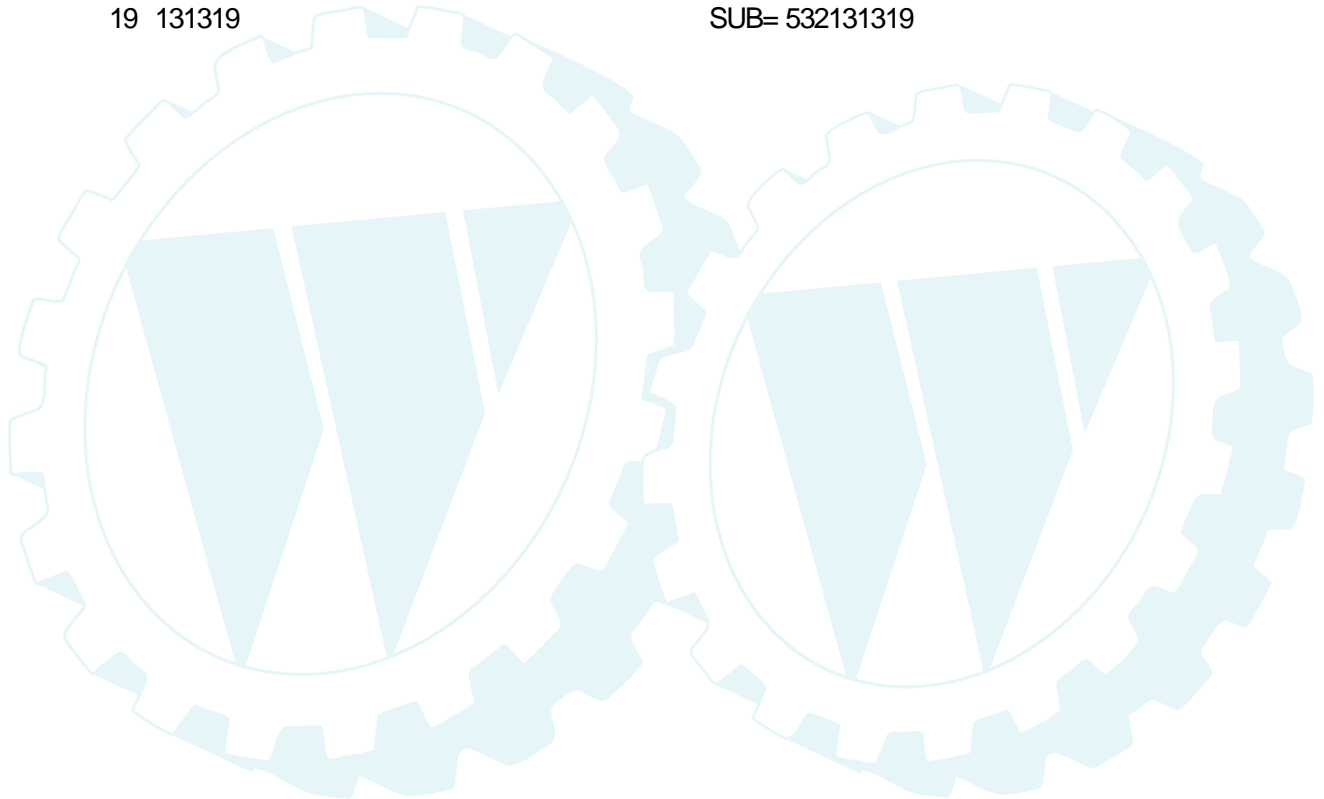

10 HP 36" TRACTOR - - MODEL NUMBER Y10L36A

MOWER DECK

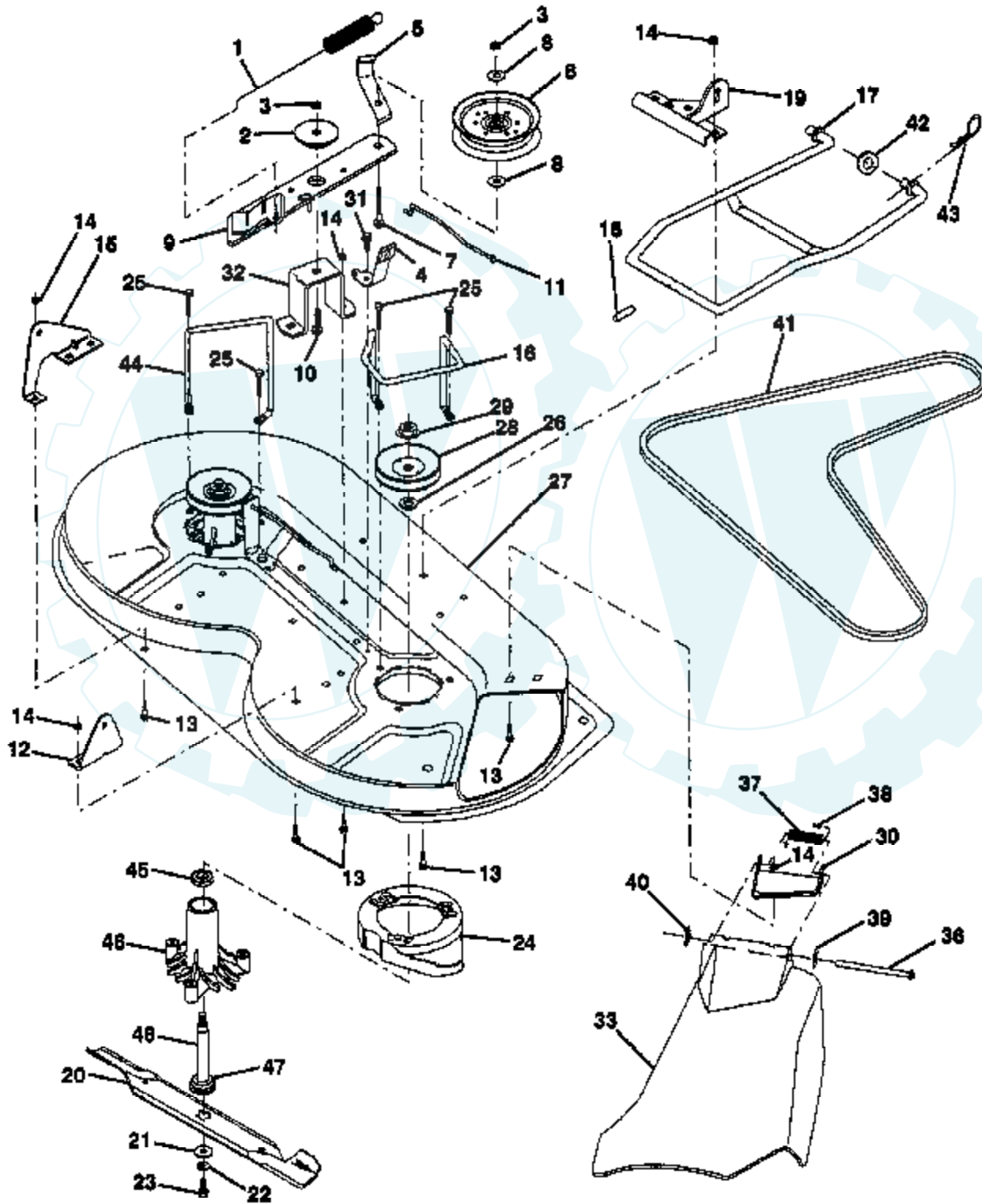

Ref #	Part Number	Qty	Description
1	127743		SUB= 140064
2	122052X		SPACER RETAINER
3	73680600		SUB= 73690600
4	130840		BRAKE ASM
5	131251		IDLER BELT GUIDE
6	121316X		PULLEY IDLER
7	72110616		BOLT
8	19131410		WASHER
9	127744		SUB= 140092
10	72110608		BOLT D
11	130841		BRAKE ROD
12	127356		"BRKT,LIFT REAR"
13	72140505		BOLT
14	73680500		SUB= 73690500
15	127357		"BRKT,LIFT REAR LH"
16	130837		SUB= 153298
17	128508		MOWER LINK STAB
18	128511		"PIN,GROOVE"
19	127380		"BRKT,LINK STABILI"
20	127841		SUB= 138496
21	129962		WASHER BLADE
22	10030600		SUB= 10040600
23	850857		BLADE BOLT
24	128961		SUB= 140329
25	78158		SUB= 17580520
26	129963		WASHER
27	129983		SUB= 156600
28	129207		SUB= 153531
29	73050900		SUB= 139729
30	126361X		SUB= 532136631
31	17490508		SCREW LT
32	122051X		"SUPT,IDLER ARM"
33	131560		SUB= 532131560
36	121980X		HINGE ROD
37	123713X		SPRING TORSION
38	105304X		CAP-SLEEVE LT
39	19111016		WASHER
40	110452X		NUT PUSH M
41	131264		V-BELT.PRIM.78.5.
42	19171616		WASHER
43	3146R		RETAINER.SPRING
44	130836		SUB= 140608
45	110485X		BEARING
46	128774		HSG ASM MANDREL
47	129895		BEARING.BALL
48	133172		SUB= 137646
	130794		MANDREL ASM
	136317		SUB= 140979

10 HP 36" TRACTOR - - MODEL NUMBER Y10L36A

MOWER LIFT LEVER

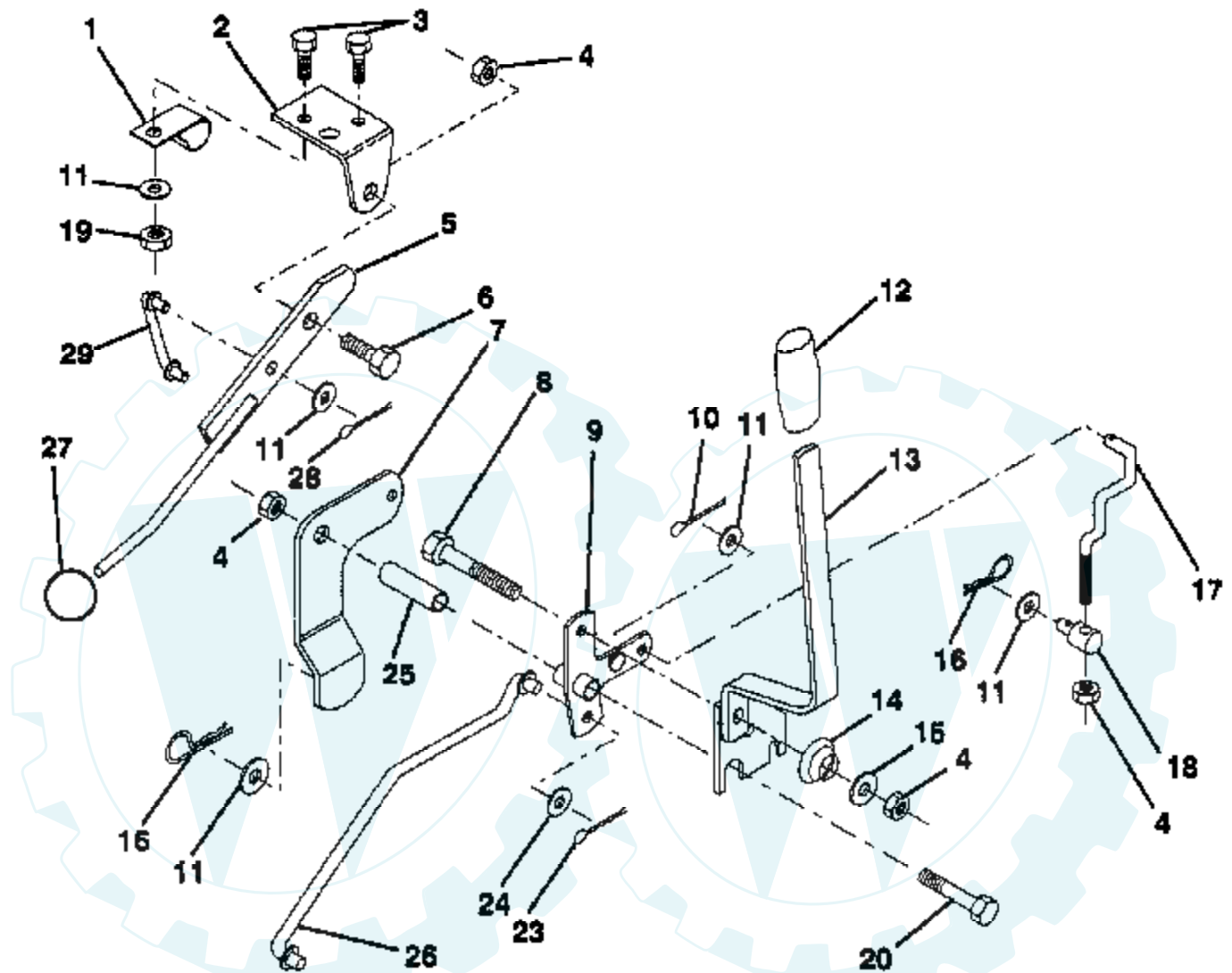

* STANDARD HARDWARE - - PURCHASE LOCALLY
NOTE: All component dimensions given in U.S. inches
1 inch = 25.4 mm

Ref #	Part Number	Qty	Description
1	126470X		"CLIP,INSULATOR"
2	122018X		BRKT CLUTCH
3	74780408		BOLT
4	73680600		SUB= 73690600
5	123417X		CLUTCH LEVER AS
6	106451X		"BOLT, SHOULDER LT"
7	135371		MWR CLUTCH ARM AS
8	74760636		BOLT
9	121930X		"BELLCRANK,LIFT"
10	76020412		COTTER PIN
11	19131316		WASHER
12	131861		SUB= 532131861
13	127028		"HDLE,LIFT T"
14	123496X		SPRING COMPRESSIO
15	19131212		WASHER T
16	4921H		SPRING.RETAINER
17	127359		"LINK,LIFT FRT"
18	133205		TRUNION
19	73680400		SUB= 73690400
20	74760644		BOLT
23	76020416		PIN COTTER 1/8
24	19171616		WASHER
25	121933X		TUBE SPACER
26	121934X		"ROD,MOWER LIFT "
27	106932X		KNOB T(3/8 HOLE)
28	76020312		SUB= 3145
29	131655		CLUTCH LINK

10 HP 36" TRACTOR - - MODEL NUMBER Y10L36A

SCHEMATIC

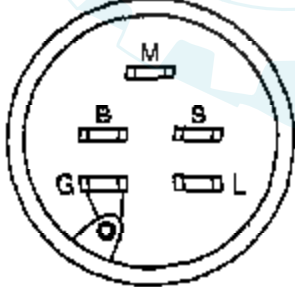
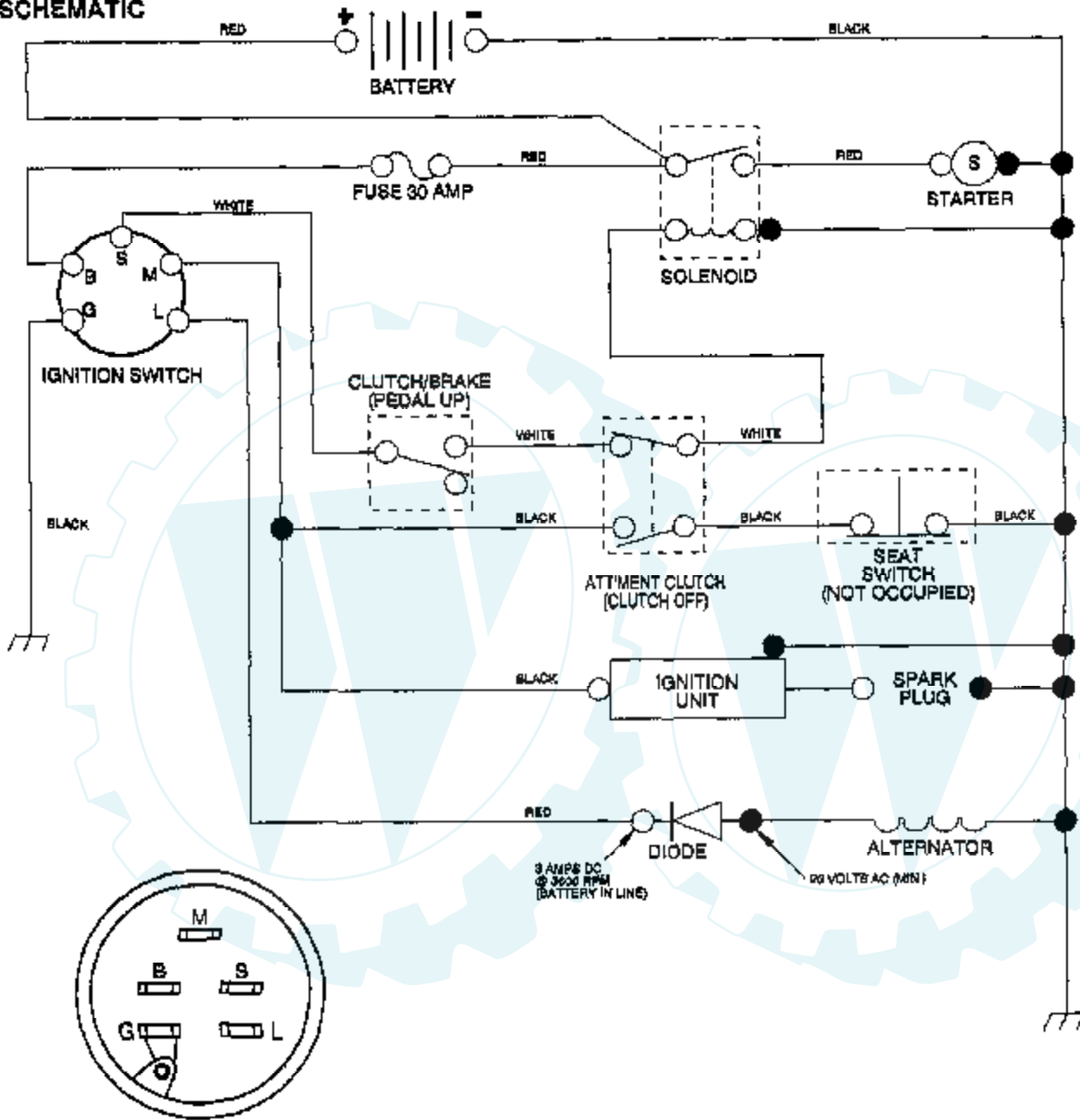

IGNITION SWITCH

POSITION	CIRCUIT
OFF	M + G
ON	B + L
START	B + S

- NON-REMOVABLE CONNECTIONS
- REMOVABLE CONNECTIONS

WIRING INSULATED CLIPS
NOTE IF WIRING INSULATED CLIPS WERE REMOVED FOR SERVICING OF UNIT, THEY SHOULD BE REPLACED TO PROPERLY SECURE YOUR WIRING

10 HP 36" TRACTOR - - MODEL NUMBER Y10L36A

SEAT

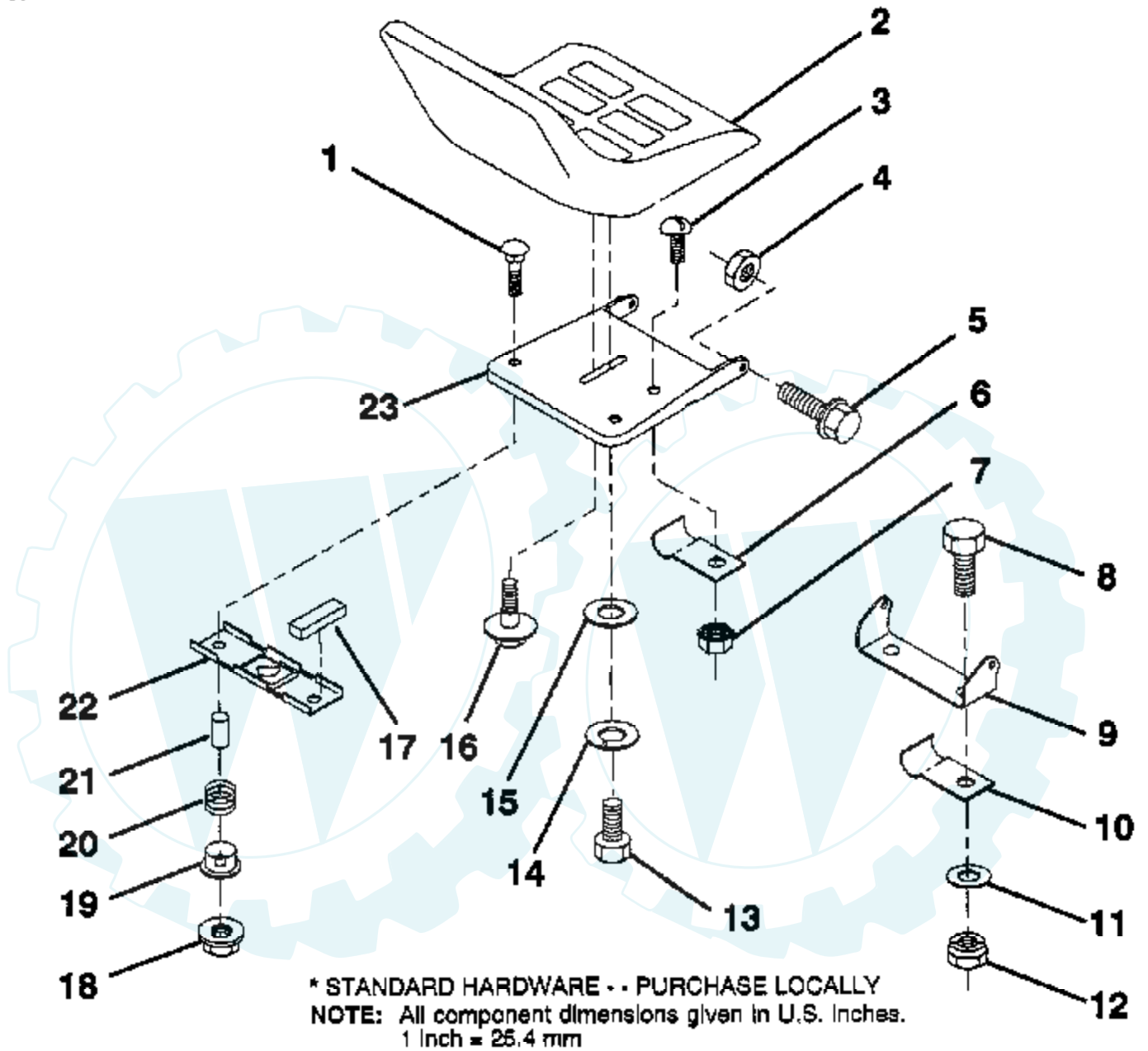

Ref #	Part Number	Qty	Description
1	72050411		SUB= 872050411
2	134647		SUB= 140119
3	74641008		SUB= 71031008
4	73680500		SUB= 73690500
5	105529X		SUB= 139888
6	4171R		CLIP T
7	73951000		"NUT,KEPS"
8	74760612		SUB= 74780612
9	126656X		SUB= 140551
10	126471X		"CLIP,INSULATOR"
11	19133210		WASHER
12	73680600		SUB= 73690600
13	74780814		BOLT
14	10040800		LOCKWASHER
15	19171912		WASHER
16	127018X		"BOLT,SHOULDER"
17	121251X		STRIP FORM
18	123976X		SUB= 73900400
19	121248X		BUSHING
20	121250X		SPRING
21	121249X		SPACER SPLIT
22	121246X		BRKT SWITCH
23	131451		SUB= 155925

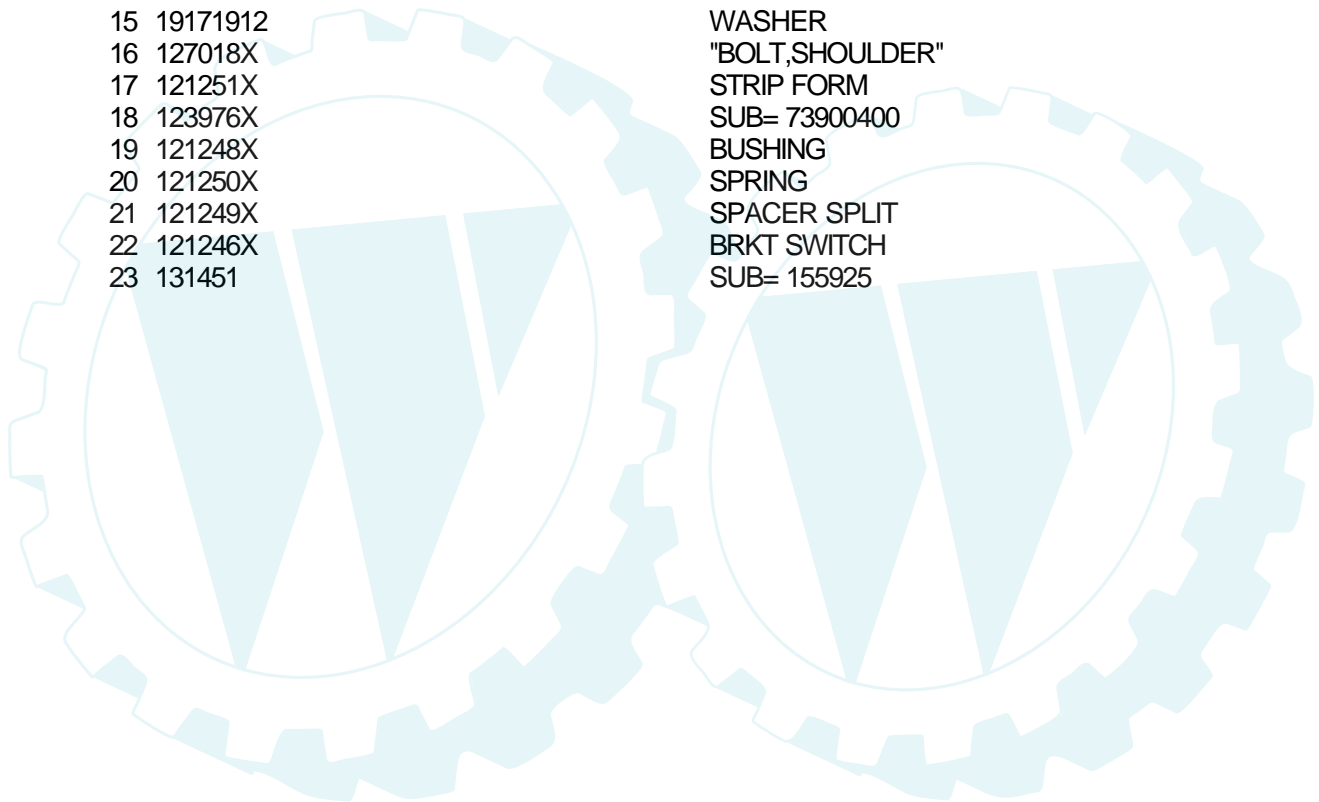

10 HP 36" TRACTOR - - MODEL NUMBER Y10L36A SECTOR GEAR / AXLE SUPPORT

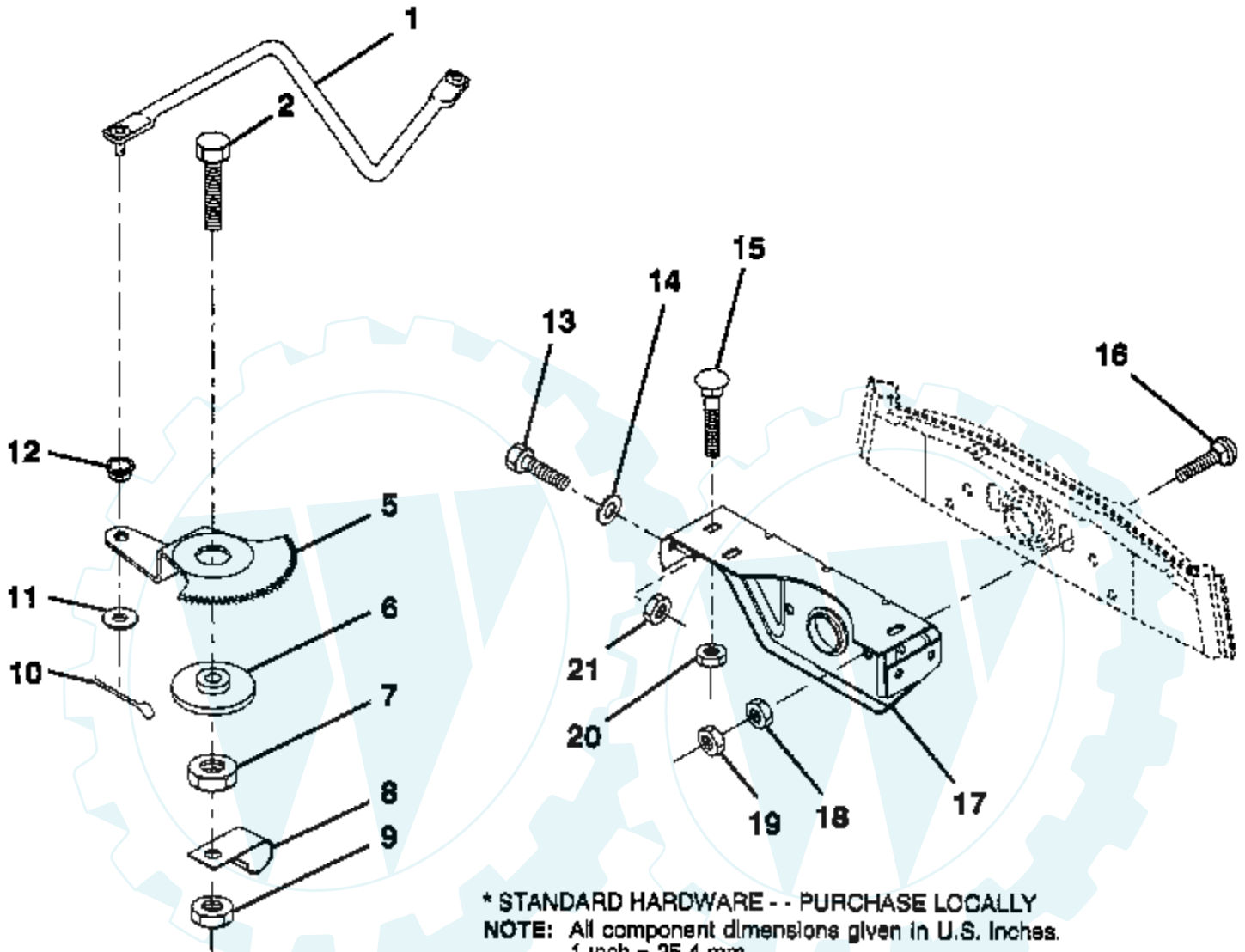

Ref #	Part Number	Qty	Description
1	132566		DRAG LINK
2	74780828		"BOLT,HEX"
5	121926X		GEAR SECTOR
6	121927X		BUSHING
7	73030800		NUT
8	126472X		CLIP INSULATOR
9	73680800		NUT LTV
10	76020412		COTTER PIN
11	19131316		WASHER
12	126847X		BUSHING.DRAGLINK
13	74760512		BOLT
14	19111416		WASHER
15	72110606		BOLT
16	72140622		BOLT
17	121912X		"SUPT,FRT AXLE"
18	73220600		NUT.HEX.3/8-16UNC
19	73930600		LOCKNUT
20	73680600		SUB= 73690600
21	73680500		SUB= 73690500

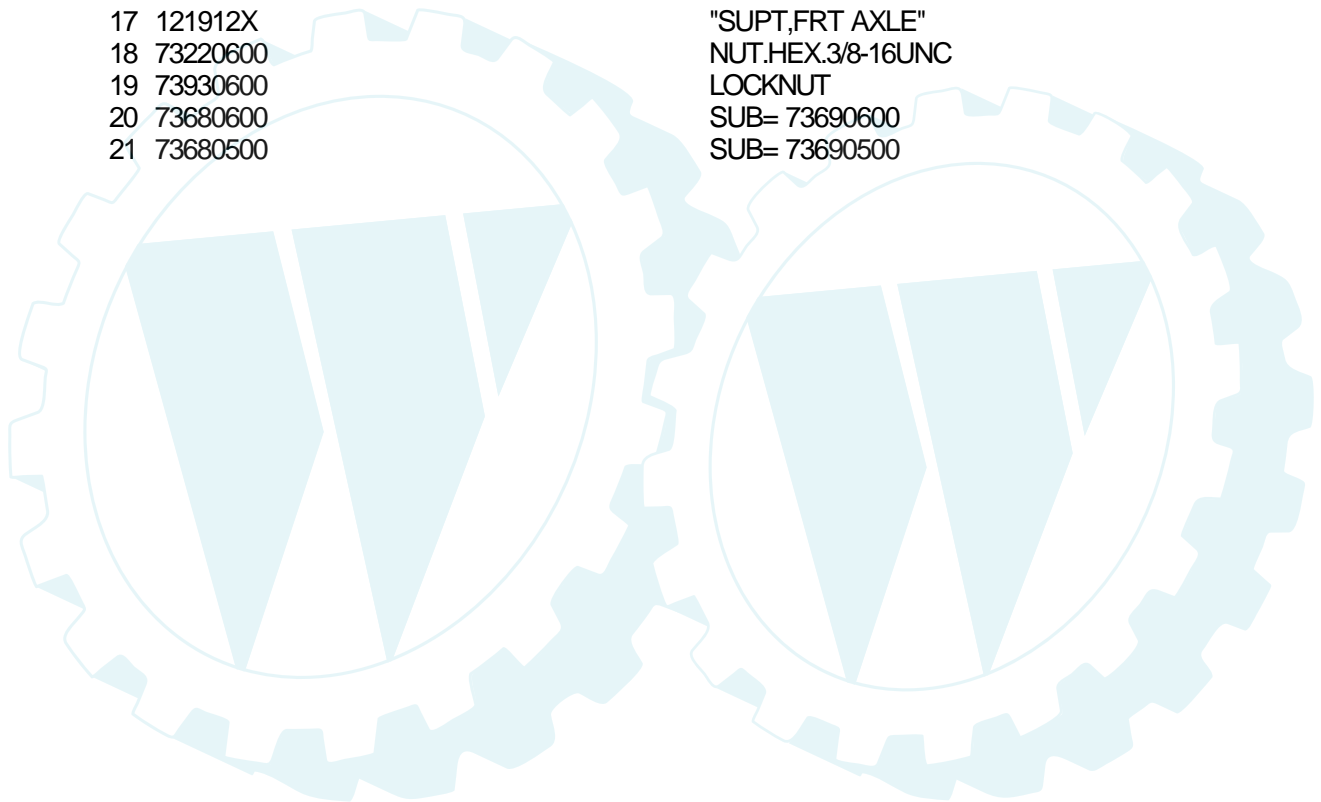

10 HP 36" TRACTOR -- MODEL NUMBER Y10L36A

STEERING WHEEL

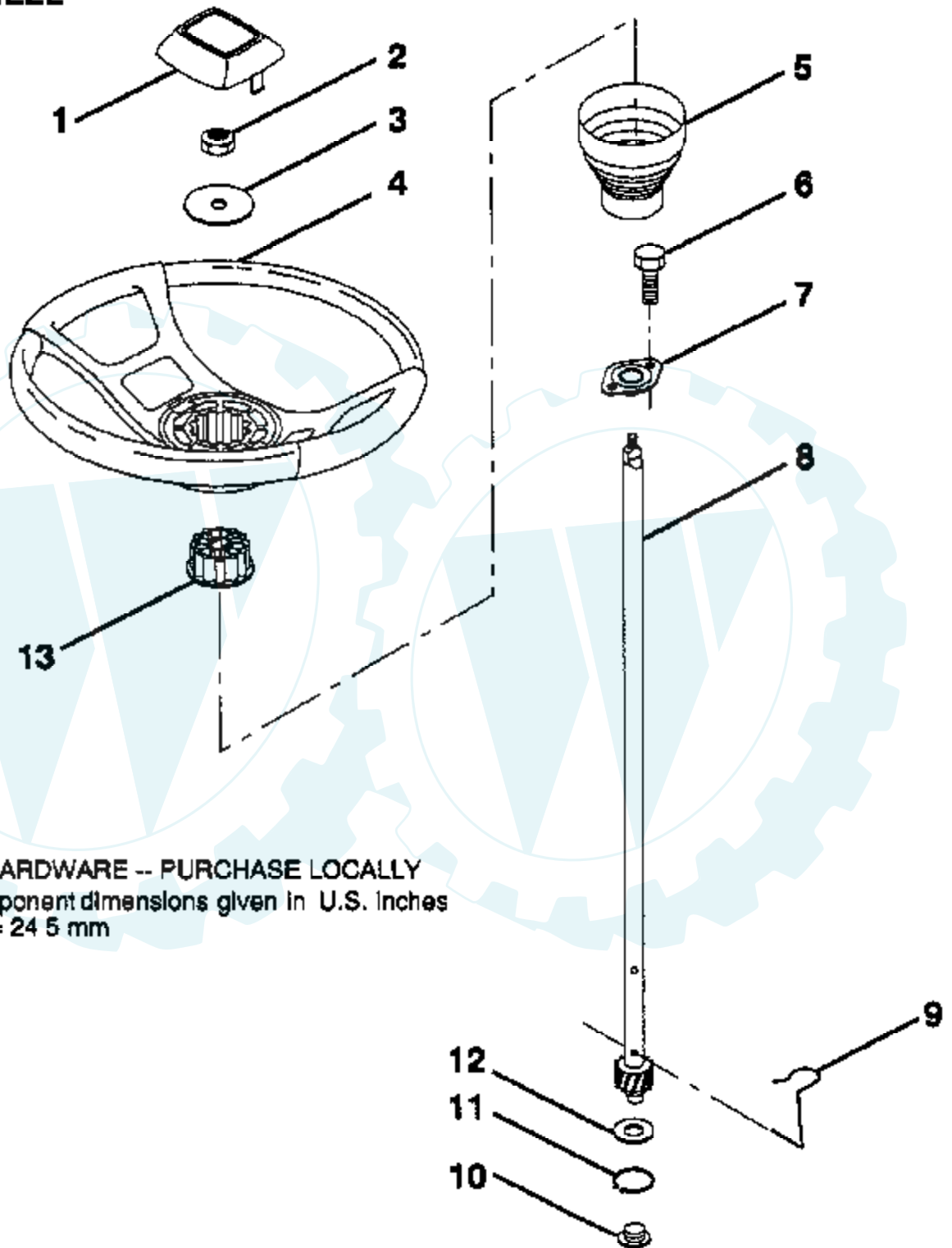

* STANDARD HARDWARE -- PURCHASE LOCALLY

NOTE: All component dimensions given in U.S. inches
1 inch = 25.4 mm

Ref #	Part Number	Qty	Description
1	133742		ST WHL INSERT CAP
2	7810H		GRIPCO NUT
3	19133808		WASHER T
4	133741		SUB= 150547
5	121897X		SLEEVE STEERING
6	17431008		SUB= 98000165
7	102803X		SUB= 918102803X
8	123651X		SUB= 148966
9	124210X		STEERING CLIP
10	123438X		BUSHING STEER LWR
11	12000045		RING
12	19211616		WASHER LT
13	104820X		ADAPTER-WHEEL LT



10 HP 36" TRACTOR - - MODEL NUMBER Y10L36A
DANA TRANSAXLE - MODEL NUMBER 4360-15

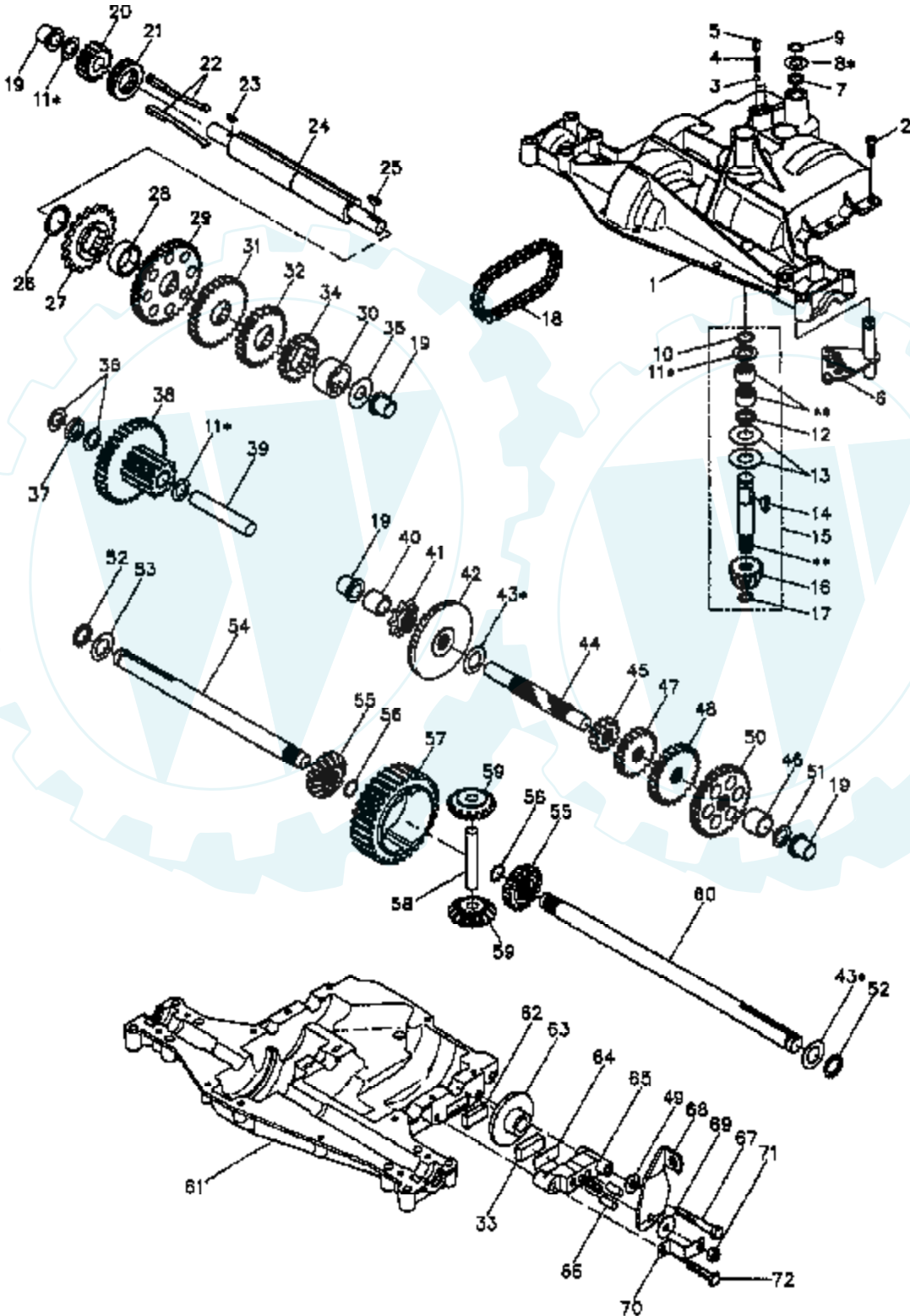

Ref #	Part Number	Qty	Description
1	3865		HOUSING UPPER
2	1919		SCREW
3	1151		BALL DETENT
4	3626		SPRING, DETENT
5	3623		SCREW, SET
6	4336		ASSY SHIFTER
7	3884		O-RING
8	3885		WASHER PLAIN
8A	3886		WASHER PLAIN
8B	3887		WASHER PLAIN
8C	3888		WASHER PLAIN
8D	3889		WASHER PLAIN
8E	3121		WASHER PLAIN
8F	3890		WASHER PLAIN
9	1100		RING RETAINING
10	1099		RING RETAINING
11	1959		WASHER PLAIN
11A	1441		WASHER PLAIN
11B	1423		WASHER, PLAIN .632 X 1.00 X .026
11C	1082		WASHER PLAIN
11D	1424		WASHER PLAIN
11E	1068		WASHER PLAIN
11F	1425		WASHER PLAIN
11G	1358		WASHER PLAIN
11H	1145		WASHER, PLAIN .632 X 1.00 X .060
11I	1319		WASHER PLAIN
12	3312		O-RING
13	3876		WASHER, PLAIN .632 X 1.38 X .046
14	1374		KEY WOODRUFF #9
15	4134		ASSY KIT INPUT SHAFT
16	3590		PINION, BEVEL, 14 TEETH
17	3624		RING, RETAINING
18	3625		CHAIN, 24 PITCHES
19	1542		BEARING, FLANGE
20	3773		GEAR SPUR, 14 TEETH
21	3631		COLLAR CLUTCH
22	3828		KEY CLUTCH
23	1369		KEY WOODRUFF #3
24	3883		SHAFT INTERMEDIATE
25	1375		KEY, WOODRUFF, #61
26	3627		RING, RETAINING
27	3830		SPROCKET, 18 TEETH
28	3841		SPACER
29	3786		GEAR, SPUR, 37 TEETH
30	3685		SPACER
31	3867		GEAR, SPUR, 30 TEETH
32	3783		GEAR, SPUR, 25 TEETH
33	3907		PUCK, FRICTION
34	3741		GEAR SPUR
35	3628		WASHER, PLAIN .640 X 1.37 X .061
36	1423		WASHER, PLAIN .632 X 1.00 X .026
37	3422		SPACER .630 X 1.00 X .169
38	4286		ASSY GEAR COMB 12&35 TEETH
39	3877		SHAFT IDLER
40	3901		SPACER .635 X .875 X .755
41	3645		SPROCKET, 9 TEETH
42	3853		GEAR BEVEL 42 TEETH
43	3749		WASHER PLAIN

Ref #	Part Number	Qty	Description
43A	3652		WASHER PLAIN
43B	3693		WASHER PLAIN
43C	3653		WASHER PLAIN
43D	3408		WASHER PLAIN
43E	3732		WASHER PLAIN
43F	3184		WASHER, PLAIN .758 X 1.25 X .031
43G	3733		WASHER PLAIN
43H	3198		WASHER PLAIN
43I	3734		WASHER PLAIN
43J	3735		WASHER PLAIN
43K	3736		WASHER PLAIN
43L	3180		WASHER PLAIN
44	3882		SHAFT, DRIVE
45	3646		GEAR, SPUR, 12 TEETH
46	3684		SPACER .781 X 1.00 X .750
47	3866		GEAR, SPUR, 20 TEETH
48	3719		GEAR, SPUR, 25 TEETH
49	3906		WASHER PLAIN
50	3683		GEAR, SPUR, 31 TEETH
51	1145		WASHER, PLAIN .632 X 1.00 X .060
52	3191		SEAL FELT
53	3180		WASHER PLAIN
54	3980		AXLE LEFT HAND
55	3780		GEAR, MITER, 15 TEETH
56	3656		RING, RETAINING
57	3839		GEAR, SPUR, 32 TEETH
58	3919		SHAFT, CROSS
59	3781		GEAR, MITER, 15 TEETH
60	3981		AXLE RIGHT HAND
61	3864		HOUSING LOWER
62	3920		PUCK, FRICTION
63	3276		DISC, BRAKE
64	3758		SPACER
65	3916		JAW, BRAKE
66	3843		PIN, DOWEL
67	3915		SCREW TAPPING
68	3768		LEVER, ACTUATING
69	3760		WASHER, PLAIN .321 X 1.00 X .055
70	3917		BRACKET, ANTI-ROTATION
71	3847		LOCKNUT 5/16-24
72	3724		SCREW TAPPING
73	4300		GREASE

10 HP 36" TRACTOR -- MODEL NUMBER Y10L36A

TRANSAXLE

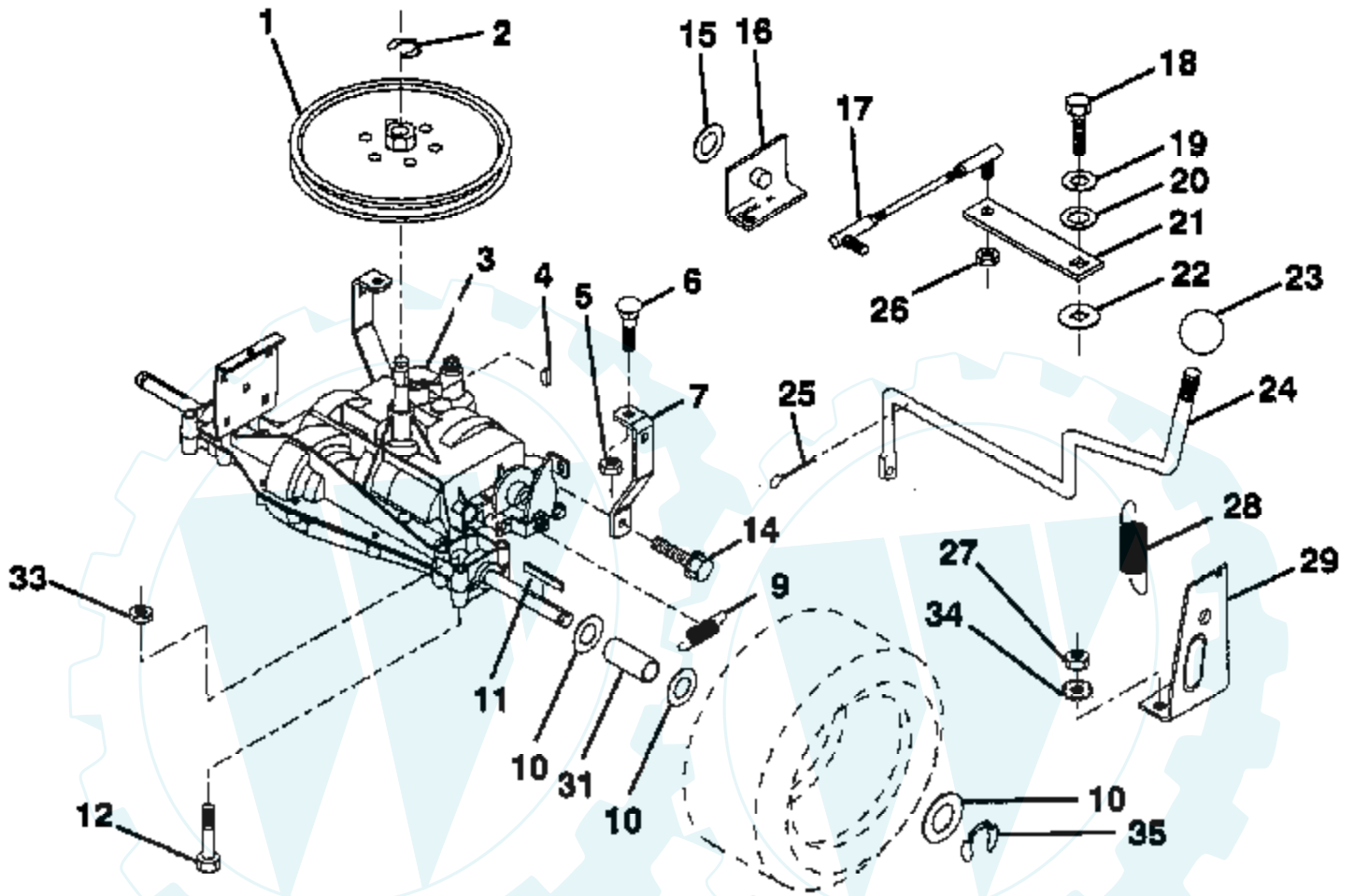

* STANDARD HARDWARE -- PURCHASE LOCALLY

NOTE: All component dimensions given in U.S. inches
1 inch = 25.4 mm

Ref #	Part Number	Qty	Description
1	123385X		PULLEY
2	12000028		SUB= 2267J
3	123383X		SUB= 142594
4	2228M		SUB= 2228M1
5	73680500		SUB= 73690500
6	72140506		BOLT
7	123378X		"STRAP,TORQUE"
9	110422X		SUB= 146682
10	121749X		WASHER
11	123583X		SQUARE KEY
12	74760644		BOLT
14	17490512		SCREW
15	19171616		WASHER
16	124600X		"SUPT,HDLE SHT LH"
17	123632X		"LINK,SHIFT"
18	71040412		SUB= 74550412
19	10040400		LOCKWASHER
20	19091210		WASHER LT
21	123484X		ARM SHIFT
22	105701X		WASH-SHFT PLT LT
23	106933X		KNOB T (1/2-HOLE)
24	128215		"ROD,SHIFT"
25	76020416		PIN COTTER 1/8
26	73810500		NUT.LOCK.5/16-24
27	73510500		NUT
28	128085		"SPRING,EXT"
29	128084		"SUPT,HDLE RH"
31	123409X		SPACER
33	73680600		SUB= 73690600
34	11050500		LOCKWASHER.5/16.E
35	12000001		E-RING LT

WHEELS

10 HP 36" TRACTOR - - MODEL NUMBER Y10L36A

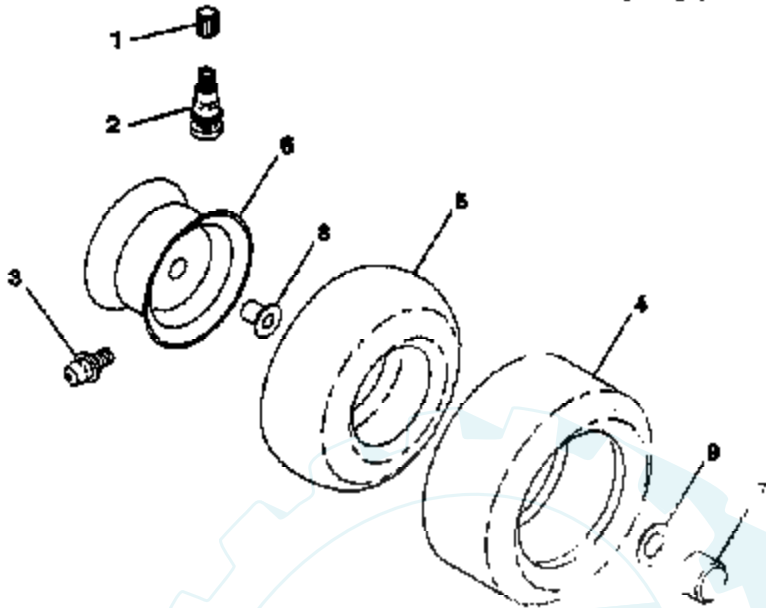

Ref #	Part Number	Qty	Description
1	59192		VALVE CAP
2	65139		VALVE STEM LT
3	278H		FITTING LT
4	124142X		SUB= 123410X
4A	124143X		SUB= 122075X
5	59904		TUBE.5.3/4.5/6
5A			REFER TO IMAGE
6	122394X361		SUB= 137237X417
6A	123412X361		RIM
7	104757X		HUB CAP
8	9040H		"FLANGE, BEARING"
9	121748X		WASHER

