

# TRACTOR - - MODEL NUMBER WEX1242C

## CHASSIS AND ENCLOSURES

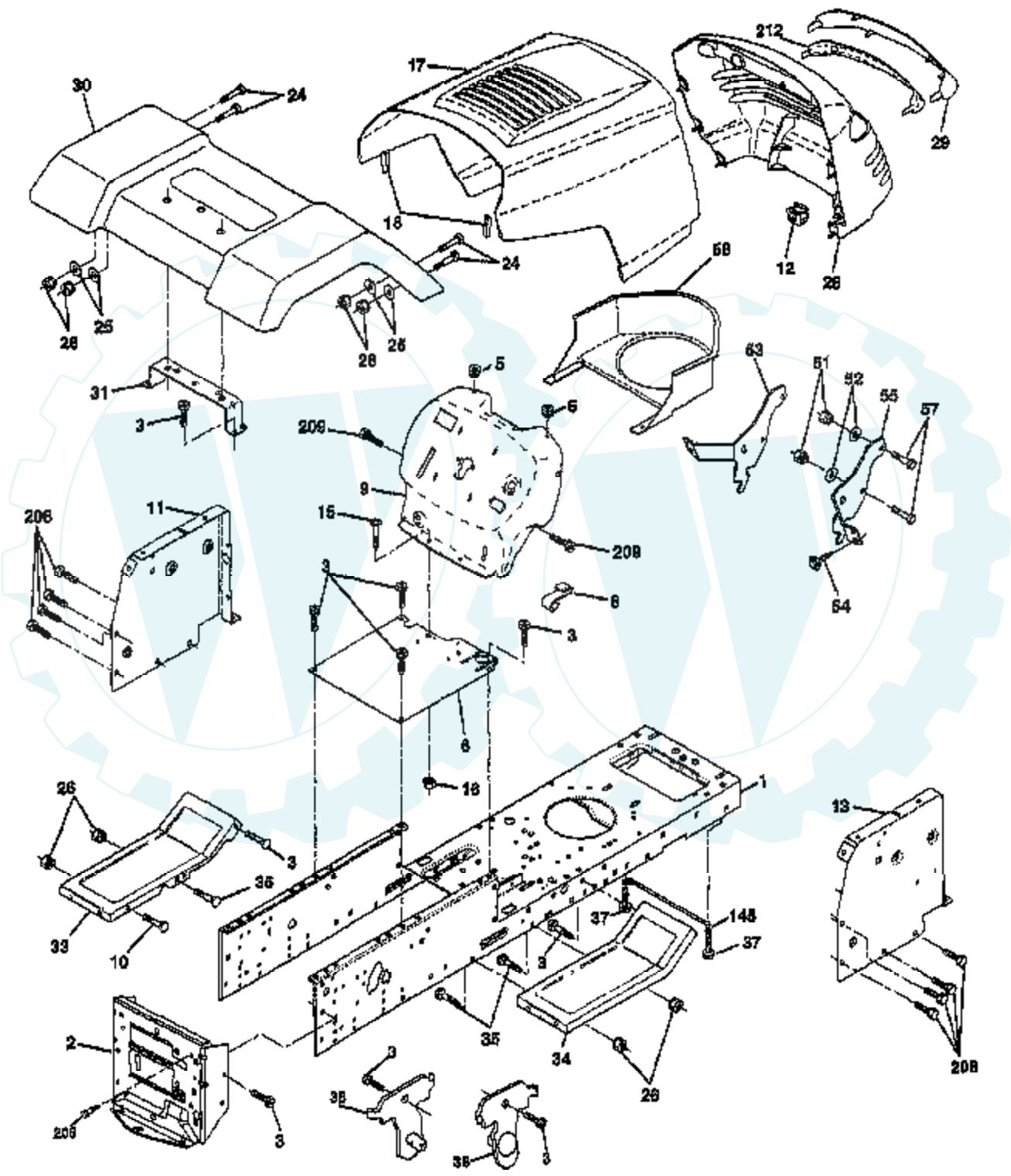

Ref #	Part Number	Qty	Description
1	169831		CHASSIS
2	169061		DRAWBAR
3	17060612		SCREW
5	155272		BUMPER-HOOD/DASH
6	155923		SADDLE
8	155138		CLIP.RETAINER
9	168347X011		DASH
10	72140608		SUB= 72110608
11	155927		"PANEL-DASH,LH"
12	145660		CLIP.TINNERMAN
13	172107X010		DASHBOARD
15	74180512		SCREW
16	73510500		NUT
17	159639X550		HOOD.STEEL.ASSY
18	126938X		SUB= 532126938
24	74780616		BOLT
25	19131312		WASHER
26	73800600		NUT
28	140434		GRILL.BLK
29	140273X599		LENS.GRILLE.PRIVATE LABEL
30	169467X550		FENDER
31	136619		BRKT FENDER
33	105476X550		FOOTREST.LH.PERF.
34	105475X550		FOOTREST.RH.PERF.
35	72110606		BOLT
37	17490508		SCREW LT
38	169834		BRKT ASM PIVOT MOWER REAR
51	7380040		NUT LOCK
52	19091416		WASHER
53	144697		BRACKET.GRILLE.LH
54	161464		SCREW.HEX.WS.HD
55	144696		BRACKET.GRILLE.RH
57	74780412		SUB= 74780414
58	150127		AIR DUCT
145	156524		"ROD POVOT,CHASSIS"
206	170165		BOLT SHOULDER
208	17670608		SCREW
209	17000612		SCREW
212	156229		INSERT LENS REFLECT
	5479J		PLUG BUTTON T

### TRACTOR - - MODEL NUMBER WEX1242C

#### DECALS

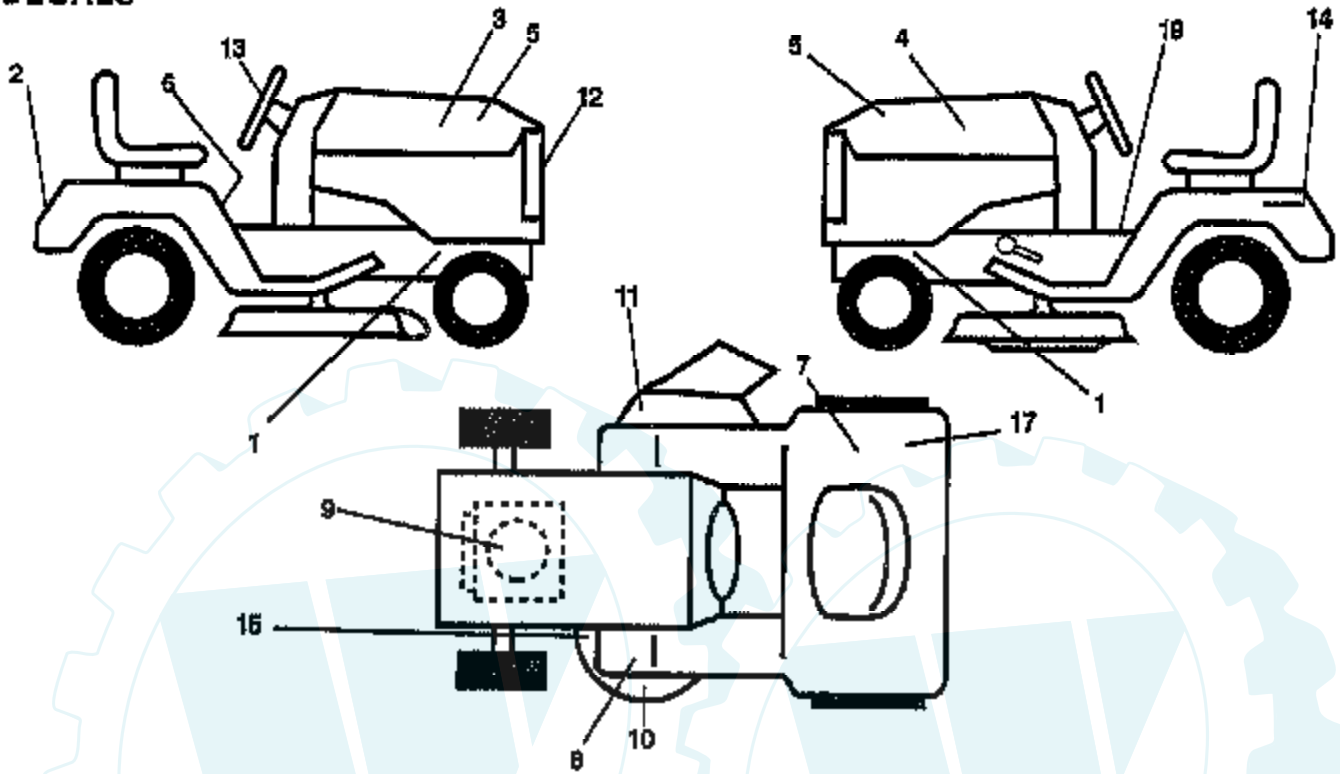

**NOTE:** All component dimensions given in U.S. inches  
1 inch = 25.4 mm

Ref #	Part Number	Qty	Description
1	159736		"DECAL CHASSIS,HOT"
2	171448		DECAL, FENDER
3	163447		DECAL.HOOD.RH
4	163448		DECAL.HOOD.LH
5	163446		DECAL.PANEL.SD
6	145498		DECAL.READ.O.MANU
7	145437		DECAL.EURO.ST.CE.
8	159737		DECAL-BRAKE/CLUTC
9	170832		DECAL, ENGINE
10	162391		DECAL, DECK GRASSEATER
11	145494		DECAL.DANGER.CUTF
12	162392		DECAL, GRILLE LENS
13	162398		DECAL, INS STRG WH
14	145005		DECAL.BATRY.3-3908
15	160396		"DECAL-SCHEM,BELT"
17	126187X		SUB= 532126187
19	140837		DECAL BRAK PARK
	138311		DECAL HANDLE LIFT
	162598		DECAL.DRAWBAR.LDL
	173324		MANUAL OPERATOR'S
	173325		MANUAL OPERATOR'S
	173326		MANUAL REPAIR PARTS
	C42		GRASS CATCHER
	MK420		MULCHING KIT W/BLADES
	C342		3 BIN BAGGER

### TRACTOR - - MODEL NUMBER WEX1242C

#### DRIVE

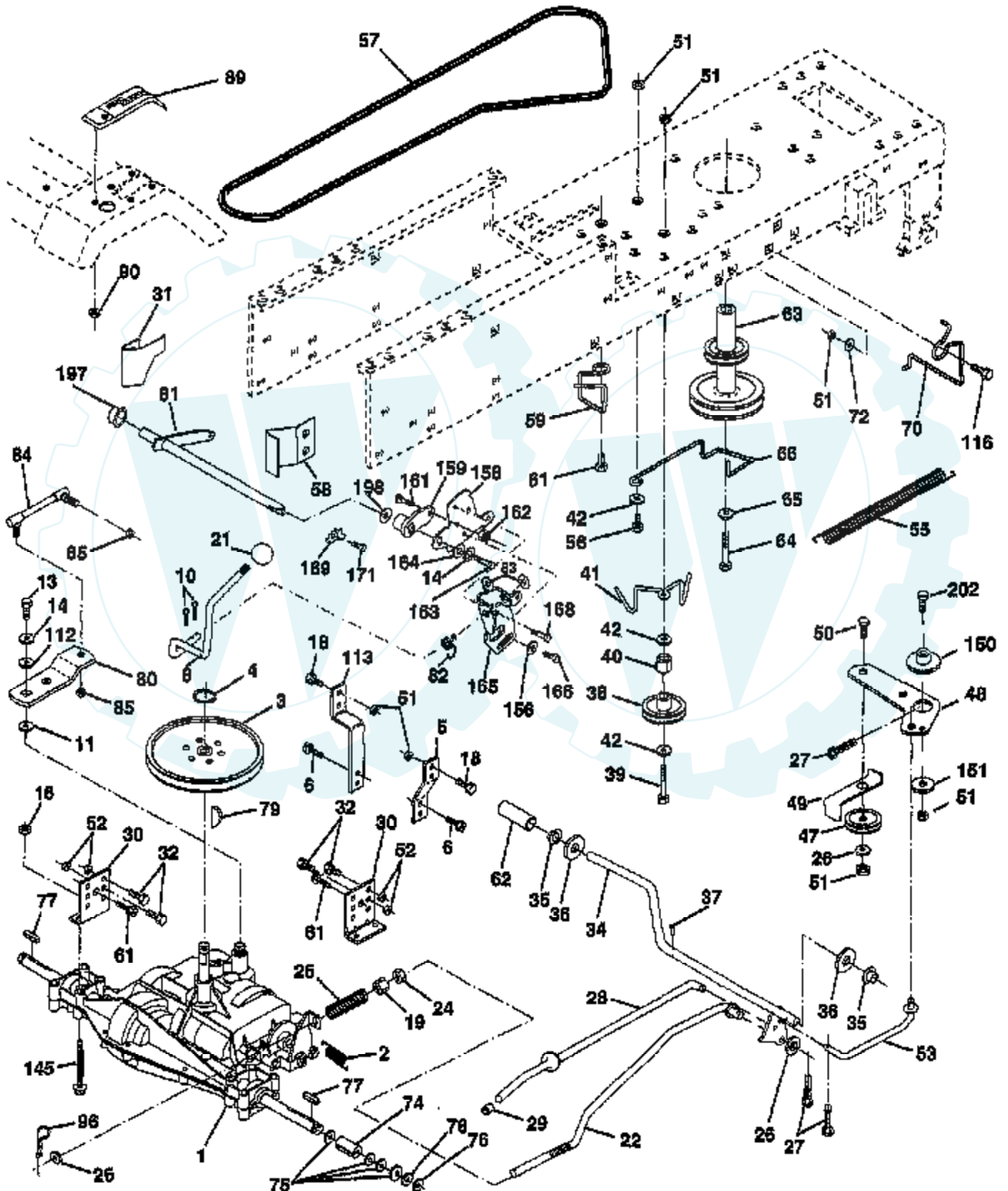

Ref #	Part Number	Qty	Description
1	SUPPLIER		CHECK WITH SUPPLIER
2	146682		SPRING.BRAKE.RETU
3	123666X		PULLEY TRANS
4	12000028		SUB= 2267J
5	121520X		STRAP TORQUE
6	17060512		SCREW
8	165619		ROD.SHIFT.FENDER.ADJ.LT.CRD
10	76020416		PIN COTTER 1/8
11	105701X		WASH-SHFT PLT LT
13	74550412		BOLT.1/4-28.W/PAT
14	10040400		LOCKWASHER
16	73800500		NUT
18	74780616		BOLT
19	73800600		NUT
21	106933X		KNOB T (1/2-HOLE)
22	130804		BRAKE ROD
24	73350600		NUT
25	106888X		SPRING ROD LT
26	19131316		WASHER
27	76020412		COTTER PIN
28	145204		ROD.BRAKE.PARK.LT
29	71673		PLUNGER CAP T
30	130807		TRANSAXLE MTG BKT
31	127275X		"KEEPER,BELT LH T"
32	74760512		BOLT
34	155071		SHAFT ASM-PEDAL F
35	120183X		NYLON BEARING
36	19211616		WASHER LT
37	1572H		SUB= 2882J
38	131494		FLAT IDLER PULLEY
39	72110622		BOLT
40	4470J		SPACER T
41	165838		"KEEPER,BELT.IDLER FLAT"
42	19131312		WASHER
47	127783		SUB= 139245
48	154407		BELLCRANK.CLUTCH
49	123205X		RETAIN BELT
50	74760624		SUB= 74930624
51	73680600		SUB= 73690600
52	73680500		SUB= 73690500
53	105710X		"LINK, CLUTCH T"
55	105710X		"LINK, CLUTCH T"
56	74760620		SUB= 74780620
57	130801		SUB= 138255
58	127274X		"KEEPER,BELT RH T"
59	169691		KEEPER BELT SPAN CTR
61	17060612		SCREW
62	8883R		PEDAL COVER T
63	140186		PULLEY.ENGINE
64	71170764		BOLT
65	10040700		LOCKWASHER
66	154778		KEEPER-BELT
70	134683		KEEPER BELT ENG
72	19132012		WASHER
74	137057		SPACER AXLE
75	121749X		WASHER
76	12000001		E-RING LT
77	123583X		SQUARE KEY

Ref #	Part Number	Qty	Description
78	121748X		WASHER
79	2228M		SUB= 2228M1
80	131486		"ROD,LINK SHIFT"
81	165594		SHAFT.ASM.CROSS
82	123782X		"SPRING,TORSION"
83	19171216		WASHER
84	166228		LINK.TRANSAXLE
85	150360		NUT.CNT.LOCK.1/4
89	169370X428		CONSOLE SHIFT
90	124346X		NUT
96	4497H		RETAINER M
112	19091210		WASHER LT
113	127285X		"STRAP,TORQUE"
116	72110610		BOLT RDHD 3/8-16
145	74490540		BOLT.HEX.FLGH
150	165850		BUSHING.BELLCRANK.GRD.DR
151	19133210		WASHER
156	166002		WASHER.SRRTD.5/16
158	165589		BRKT.SHIFT.MOUNT
159	165494		HUB.SHIFT
161	72140406		BOLT T
162	73680400		SUB= 73690400
163	74780416		NLA
164	19091010		WASHER.5/8X.281X10GA
165	165623		BRKT.PIVOT.LEVER
166	166880		SCREW.5/16-18X5/8
168	165492		BOLT.SHOULDER.5/16-18X.561
169	165581		PLATE.FASTENING
171	17490608		SCREW LT
197	169613		NYLINER SNAP-IN
198	169593		WASHER NYLINER
202	72110612		BOLT.3/8-16X1.50

### TRACTOR - - MODEL NUMBER WEX1242C

### ELECTRICAL

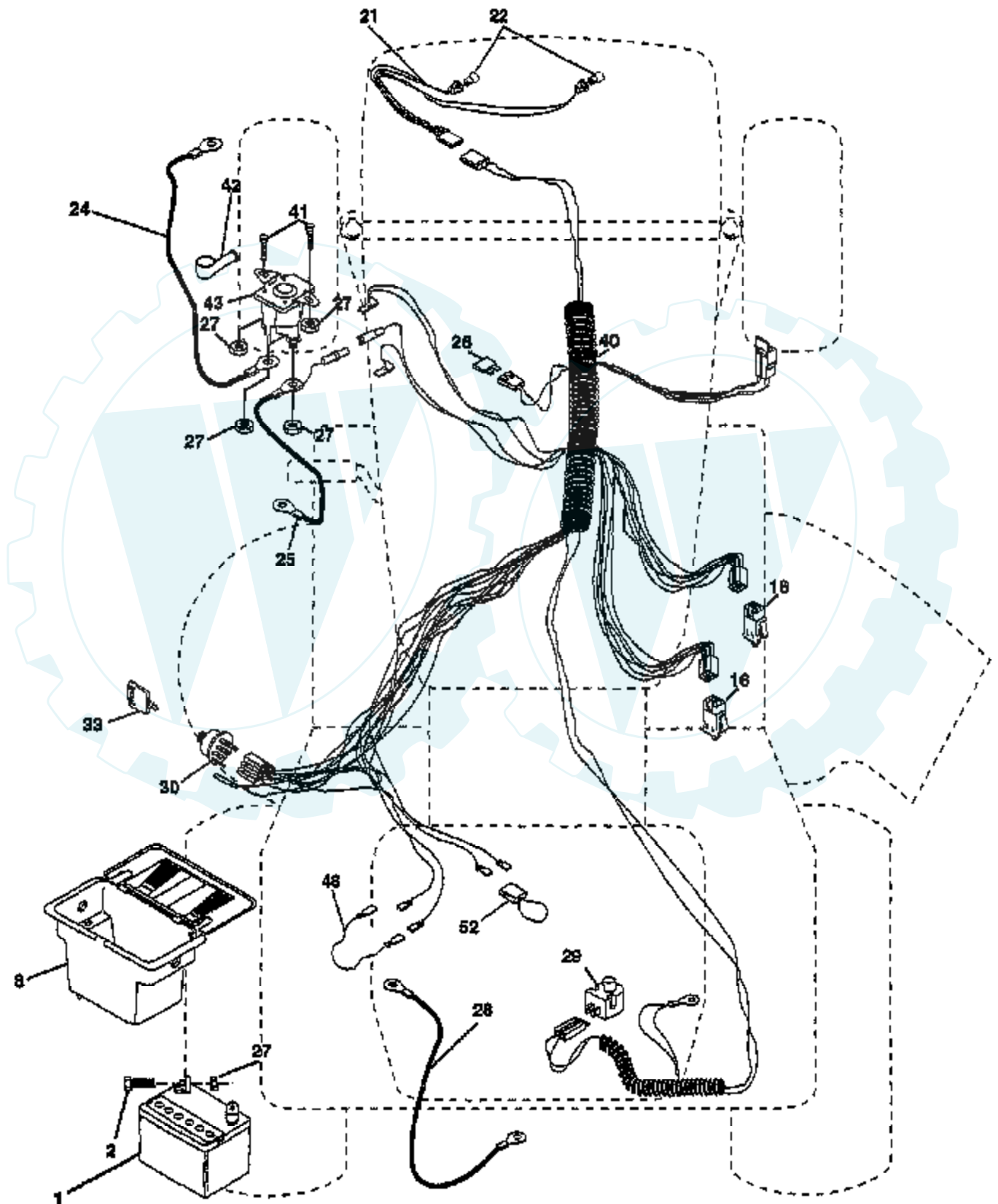



Ref #	Part Number	Qty	Description
1	144925		SUB= 123899X
2	74760412		BOLT LT
8	156417		"CASE,BATTERY.MECH"
16	153664		SWITCH INTERLOCK
21	166181		HARNESS.ASM.LIGHT W/4152J
22	4152J		HEADLAMP BULB
24	4799J		"CABLE T, BATTERY"
25	146147		CABLE.BTRY.6GA.RD
26	166180		FUSE.15 AMP
27	73510400		NUT
28	4207J		CABLE T
29	121305X		SWITCH SEAT
30	163968		SWITCH.IGN.
33	140401		KEY MLD GEN DELTA
40	170217		HARNESS IGN
41	71110408		BOLT HXHD FIN
42	131563		SUB= 154336
43	145673		SUB= 146154
48	140844		ADAPTER AMMETER
52	141940		PROTECTION LOOP

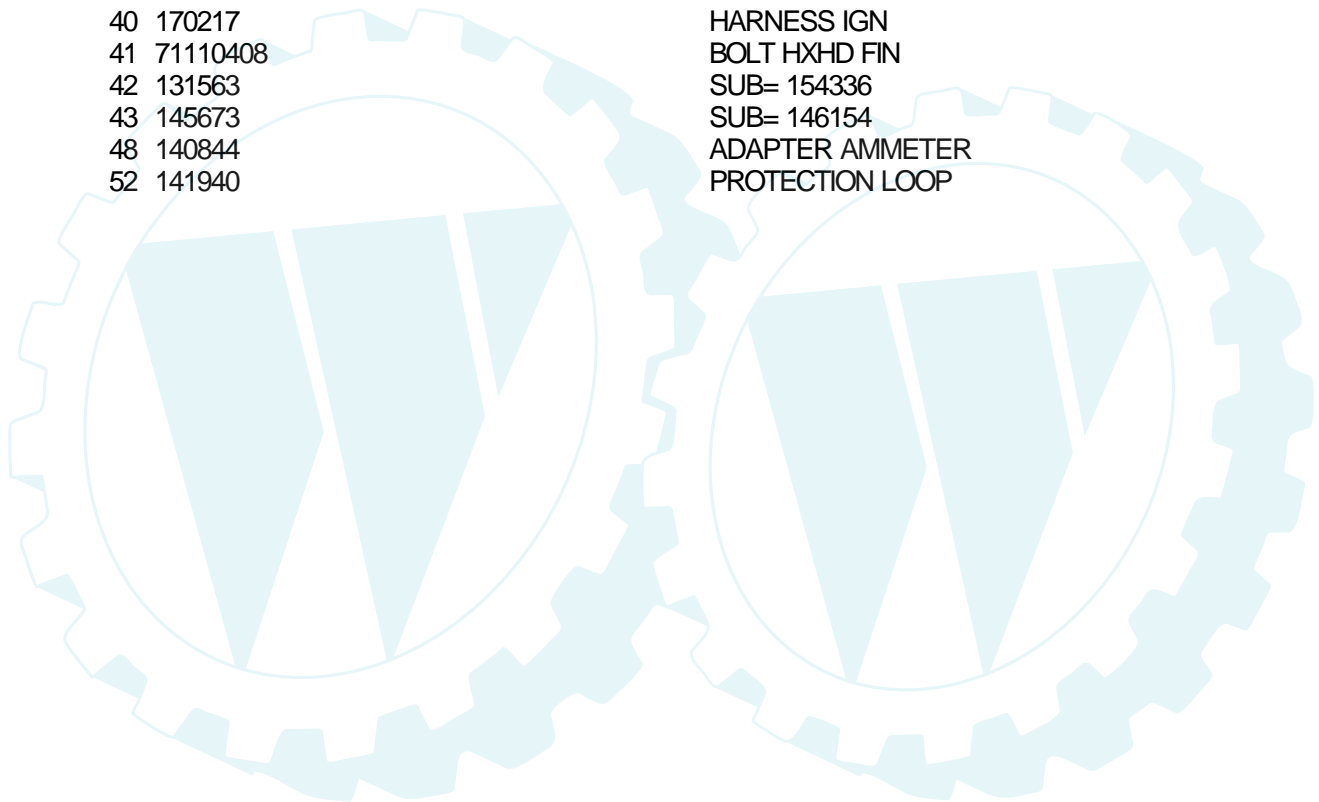

## TRACTOR - - MODEL NUMBER WEX1242C

### ENGINE

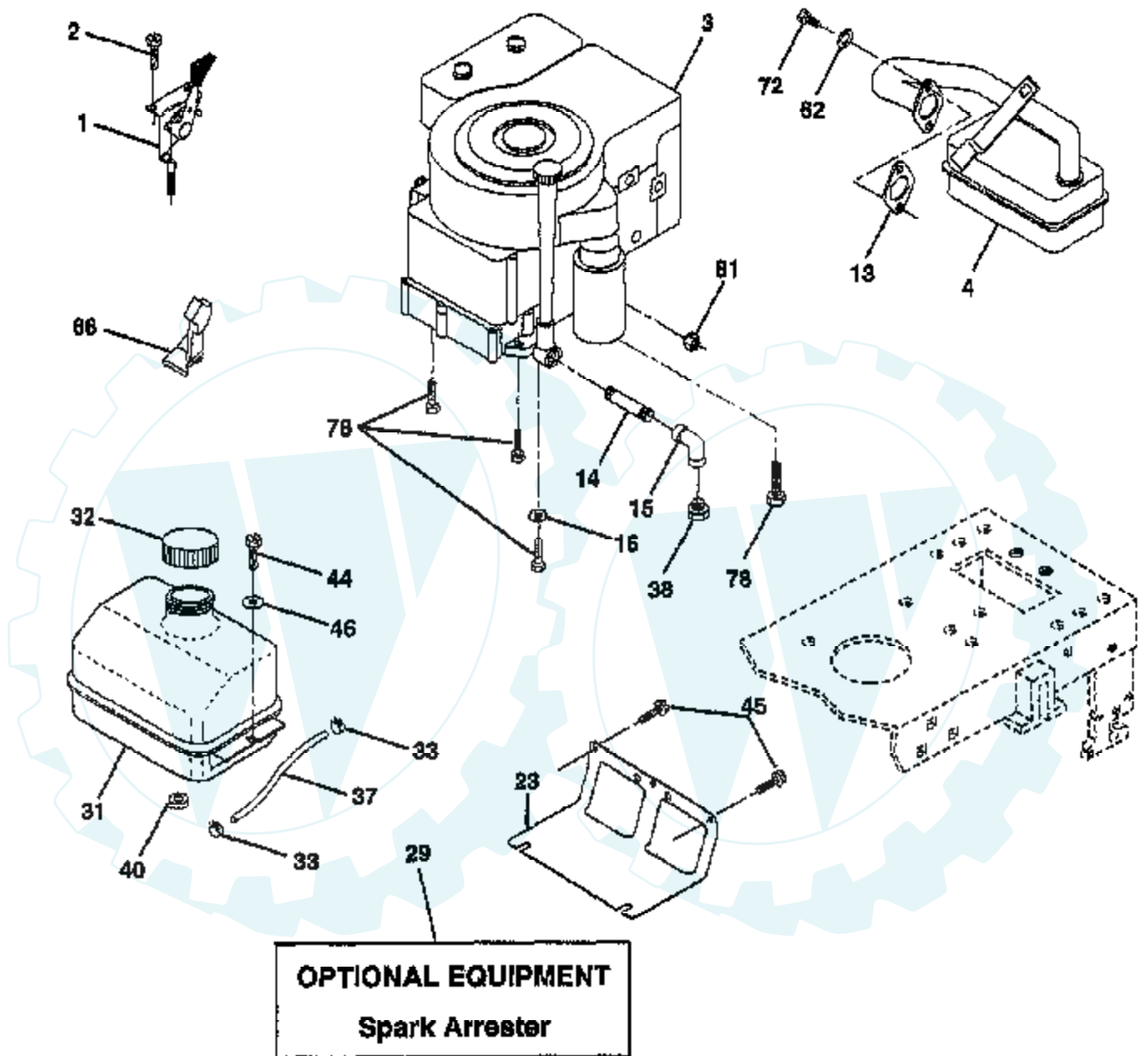

**NOTE:** All component dimensions given in U.S. inches.  
1 inch = 25.4 mm.

Ref #	Part Number	Qty	Description
1	141359		CONTROL.THTL.23.5
2	17720410		SCREW LT
3	SUPPLIER		CHECK WITH SUPPLIER
4	137348		MUFFLER
13	165291		SUB= 272293
14	13280324		PIPE NIPPLE
15	13200300		ELBOW
16	11050600		LOCKWASHER
23	169837		SHIELD BROWNING
29	137180		SUB= 532137180
31	109202X		TANK.FUEL.LT.
32	140527		CAP ASM FUEL
33	123487X		HOSE CLAMP
37	137040		LINE FUEL
38	SUPPLIER		CHECK WITH SUPPLIER
40	124028X		SUB= 532124028
44	17670412		SCREW
45	17000612		SCREW
46	19091416		WASHER
62	10040500		LOCKWASHER
66	127951		"STOP,DASH THROTT"
72	71070512		SCREW
78	17060620		SCREW
81	73510400		NUT

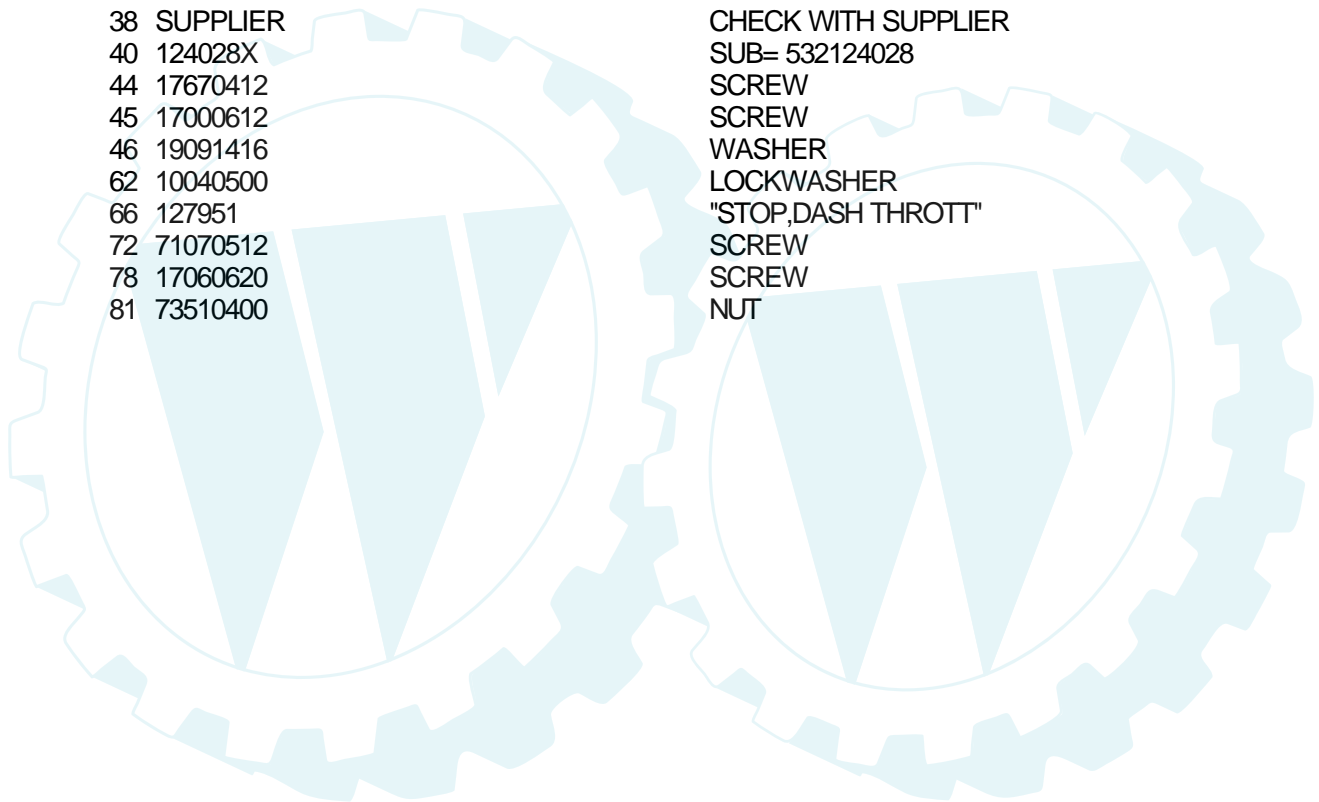



Ref #	Part Number	Qty	Description
1	165892		MOWER DECK ASSY
2	72140506		BOLT
3	138017		BRKT ASM SWAY BAR
4	165460		BRACKET DECK
5	4939M		SUB= 85902
6	130832		SUB= 130833
8	850857		BLADE BOLT
9	10030600		SUB= 10040600
10	140296		WASHER.HARD.BLADE
11	138498		"BLADE.42"" HIPERF"
12	129895		BEARING.BALL
13	137645		SUB= 137646
14	128774		HSG ASM MANDREL
15	110485X		BEARING
16	140329		STRIPPER RND MWR
18	72140505		BOLT
19	132827		BOLT SHD 5/16-18
20	159770		BAFFLE VORTEX 42
21	73680500		SUB= 73690500
22	134753		STIFFENER BRKT
23	131267		DEFLECTOR BRKT
24	105304X		CAP-SLEEVE LT
25	123713X		SPRING TORSION
26	110452X		NUT PUSH M
27	130968X428		SHIELD DEFLECTOR 42"
28	19111016		WASHER
29	131491		HINGE ROD
30	157722		"SCREW-THD ROLL,WA"
31	129963		WASHER
32	153535		PULLEY.MANDREL.42
33	137266		SUB= 139729
34	72110614		BOLT
35	133835		XMAS TREE FASTNER
36	131494		FLAT IDLER PULLEY
37	19131316		WASHER
40	73680600		SUB= 73690600
44	140088		GUARD MAND LH BLK
45	4497H		RETAINER M
46	137729		SCREW.1/4-20X5/8
48	133944		HARD SMALL WASHER
49	155066		ROLLER ASM-CAM
50	131340		SHOULDER BOLT
51	69180		LOCKNUT
52	69180		LOCKNUT
53	131845		BRAKE PAD ARM ASM
54	133943		HARDENED WASHER
55	155046		ARM-IDLER
56	165723		SPACER.RETAINER.MOWER
59	141043		GUARD IDLER TUV
67	106932X		KNOB T(3/8 HOLE)
68	144959		BELT-V.SEC.46.KEL
121	143723		BRACKET.EXTRD.GWL
128	153390		WASHER.FELT.
142	165890		ARM SPRING BRAKE MOWER
143	157109		BRACKET ARM IDLER
144	158634		KEEPER BELT CLUTCH CABLE
145	165888		PULLEY IDLER FLAT
146	165891		BOLT

Ref #	Part Number	Qty	Description
147	131335		SPRING EXTENSION
148	169022		SPRING RETURN IDLER
149	165898		RETAINER SPRING
150	19091216		WASHER PM
151	169670		BRKT CLUTCH CABLE
152	169676		"CABLE.CLUTCH.42""
153	169674		WASHER FLAT
154	169675		SPRING RETAINER
155	169671		SPRING RETENTION LVR CLUTCH CAB
156	169672		SPACER
157	169669		ROD.CLUTCH.CABLE.3/8
158	17720410		SCREW LT
159	72140614		BOLT
	130794		MANDREL ASM
	171639		MOWER DECK COMPLETE

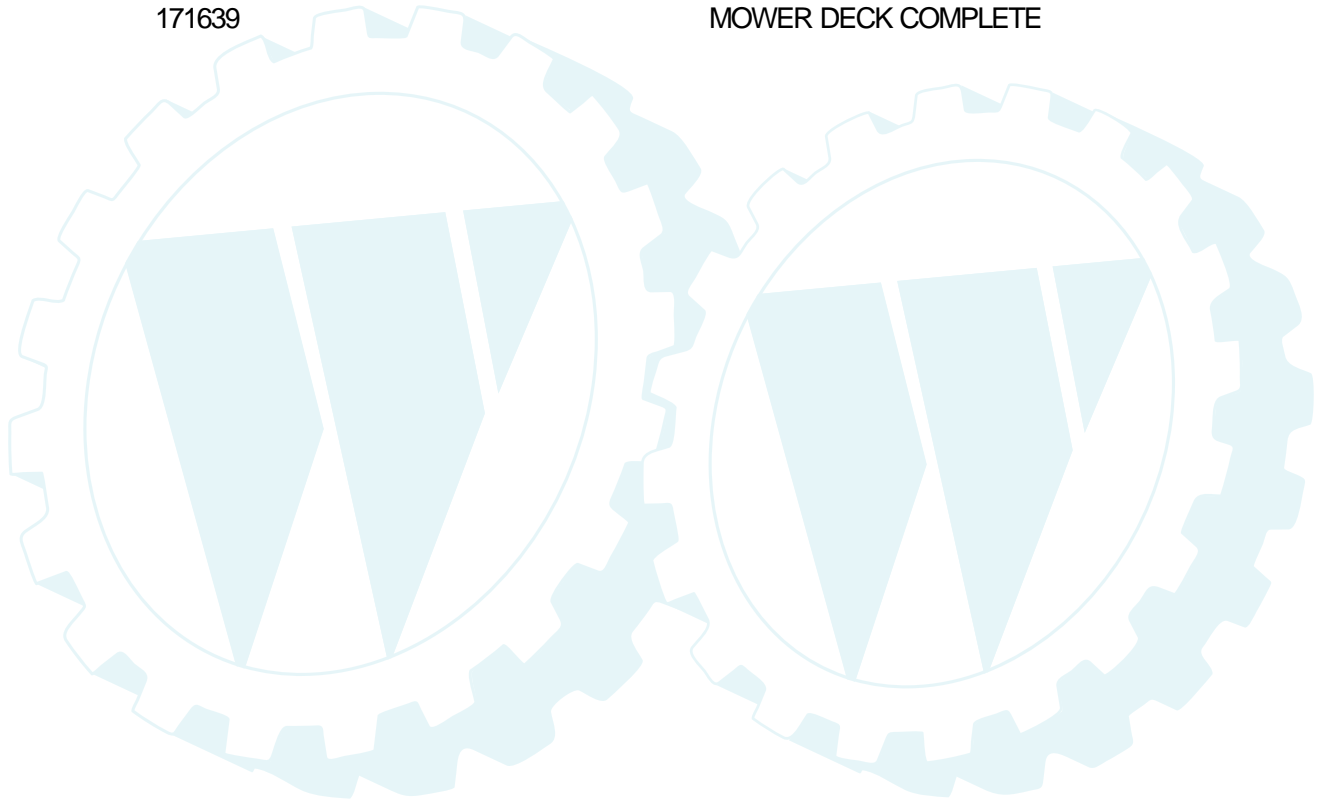

## TRACTOR - - MODEL NUMBER WEX1242C

### MOWER LIFT

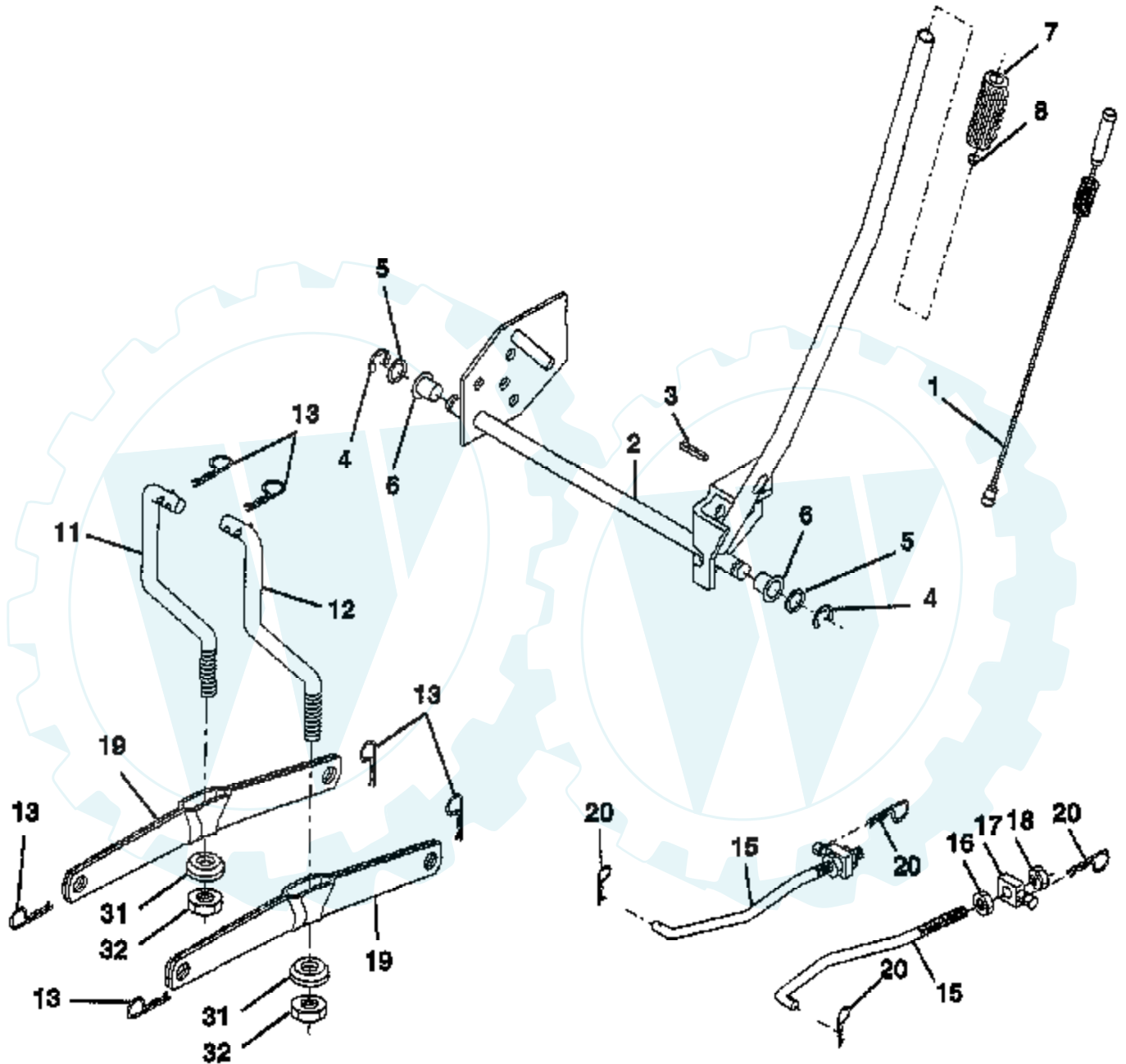

**NOTE:** All component dimensions given in U.S. inches  
1 inch = 25.4 mm

Ref #	Part Number	Qty	Description
1	159460		WIRE ASM W.SPRING
2	159471		"SHAFT ASM LIFT,RH"
3	105767X		PIN-GROOVE LT
4	12000002		SUB= 2225J
5	19211621		WASHER
6	120183X		NYLON BEARING
7	109413X		GRIP
8	124526X		SUB= 125925X
11	139865		SUB= 918139865
12	139866		SUB= 151140
13	4939M		SUB= 85902
15	173288		LINK, FRONT
16	73350800		NUT
17	130171		TRUNION
18	73800800		NUT.LK.W/WSH.1/2.
19	139868		ARM SUSP REAR
20	163552		RETAINER SPRING
31	140302		BEARING PVT LH
32	73540600		NUT.CROWNLOCK.3/8

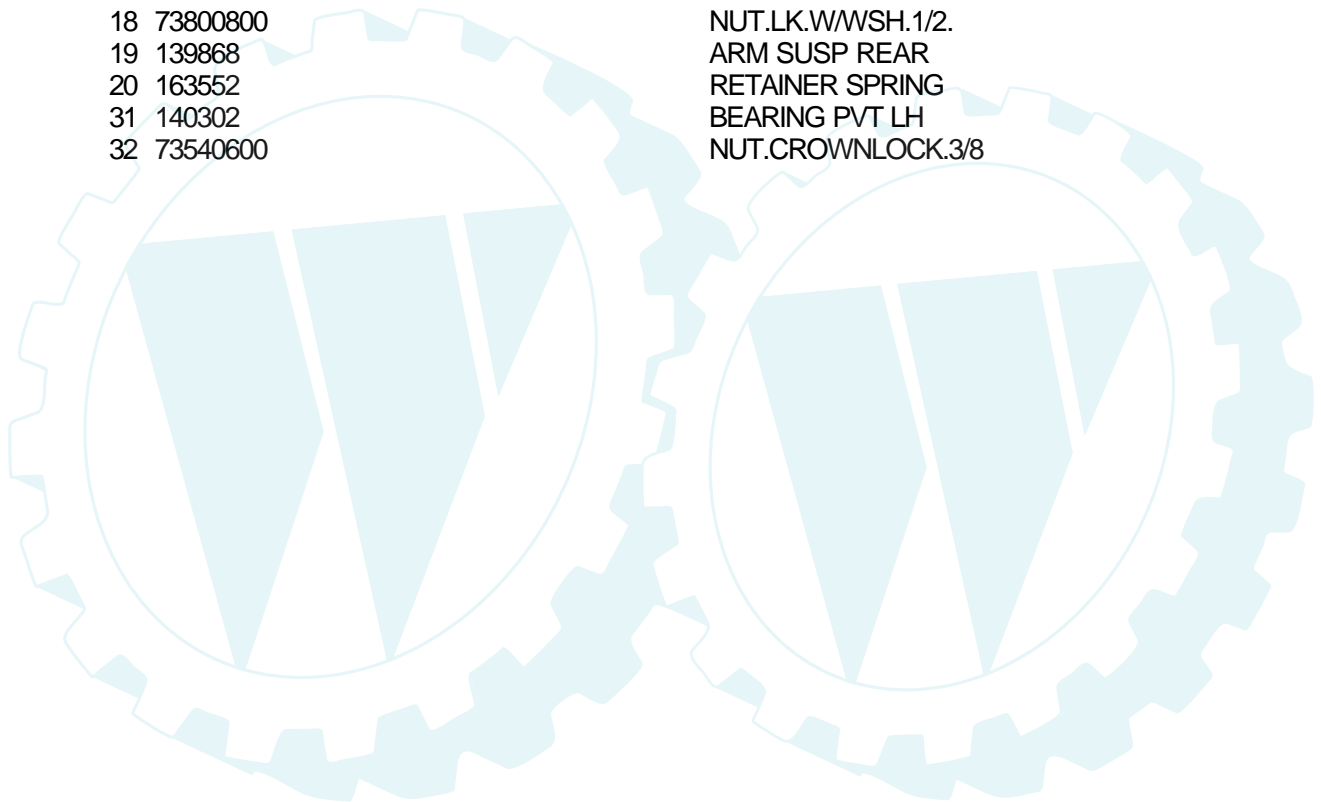



**TRACTOR - - MODEL NUMBER WEX1242C**

**SCHEMATIC**

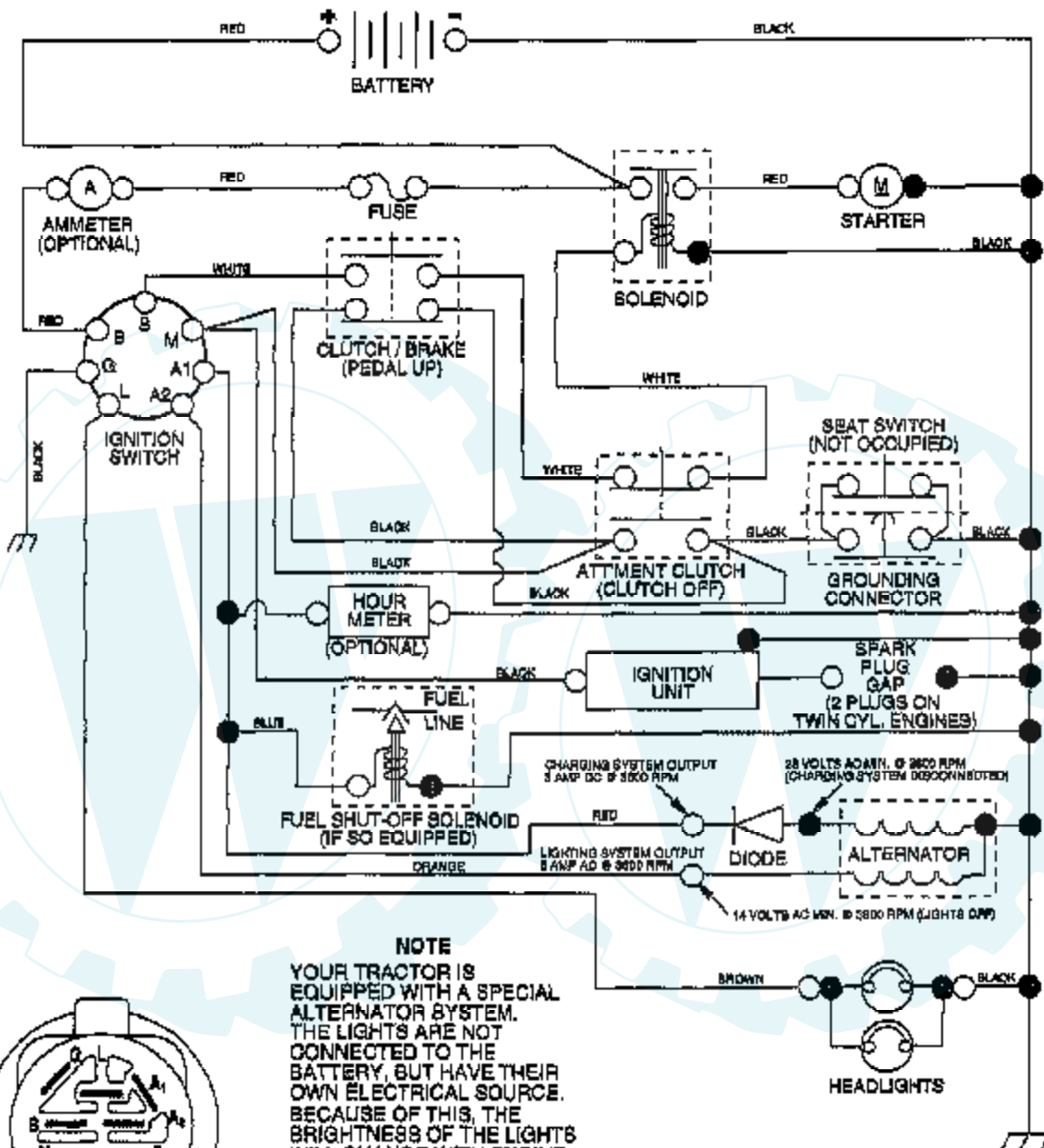

**NOTE**  
YOUR TRACTOR IS EQUIPPED WITH A SPECIAL ALTERNATOR SYSTEM. THE LIGHTS ARE NOT CONNECTED TO THE BATTERY, BUT HAVE THEIR OWN ELECTRICAL SOURCE. BECAUSE OF THIS, THE BRIGHTNESS OF THE LIGHTS WILL CHANGE WITH ENGINE SPEED. AT IDLE THE LIGHTS WILL DIM. AS THE ENGINE IS SPEEDED UP, THE LIGHTS WILL BECOME THEIR BRIGHTEST.

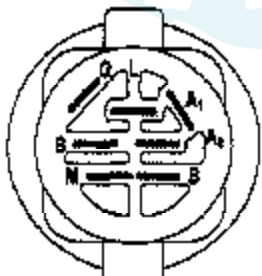

**IGNITION SWITCH**

POSITION	CIRCUIT	"BRAKE"
OFF	M+G+A1	NONE
RUN/LIGHT	B+A1	A2+L
RUN	B+A1	NONE
START	B+G+A1	NONE

**WIRING INSULATED CLIPS**

**NOTE:** IF WIRING INSULATED CLIPS WERE REMOVED FOR SERVICING OF UNIT, THEY SHOULD BE REPLACED TO PROPERLY SECURE YOUR WIRING.

NON-REMOVABLE CONNECTIONS

REMOVABLE CONNECTIONS



Ref #	Part Number	Qty	Description
1	127428		SUB= 140119
2	140551		BRACKET PVT SEAT
3	71110616		BOLT
4	19131610		WASHER PM
5	145006		CLIP.PUSH-IN.HING
6	73800600		NUT
7	124181X		SPRING COMPRESSIO
8	17000616		SCREW
9	19131614		WASHER
10	155925		PAN-SEAT
12	121246X		BRKT SWITCH
13	121248X		BUSHING
14	72050412		BOLT-RD HD SQ NK
15	134300		SPLIT SPACER
16	121250X		SPRING
17	123976X		SUB= 73900400
21	171852		BOLT
22	73800500		NUT
23	74780814		BOLT
24	19171912		WASHER
25	127018X		"BOLT,SHOULDER"
26	10040800		LOCKWASHER

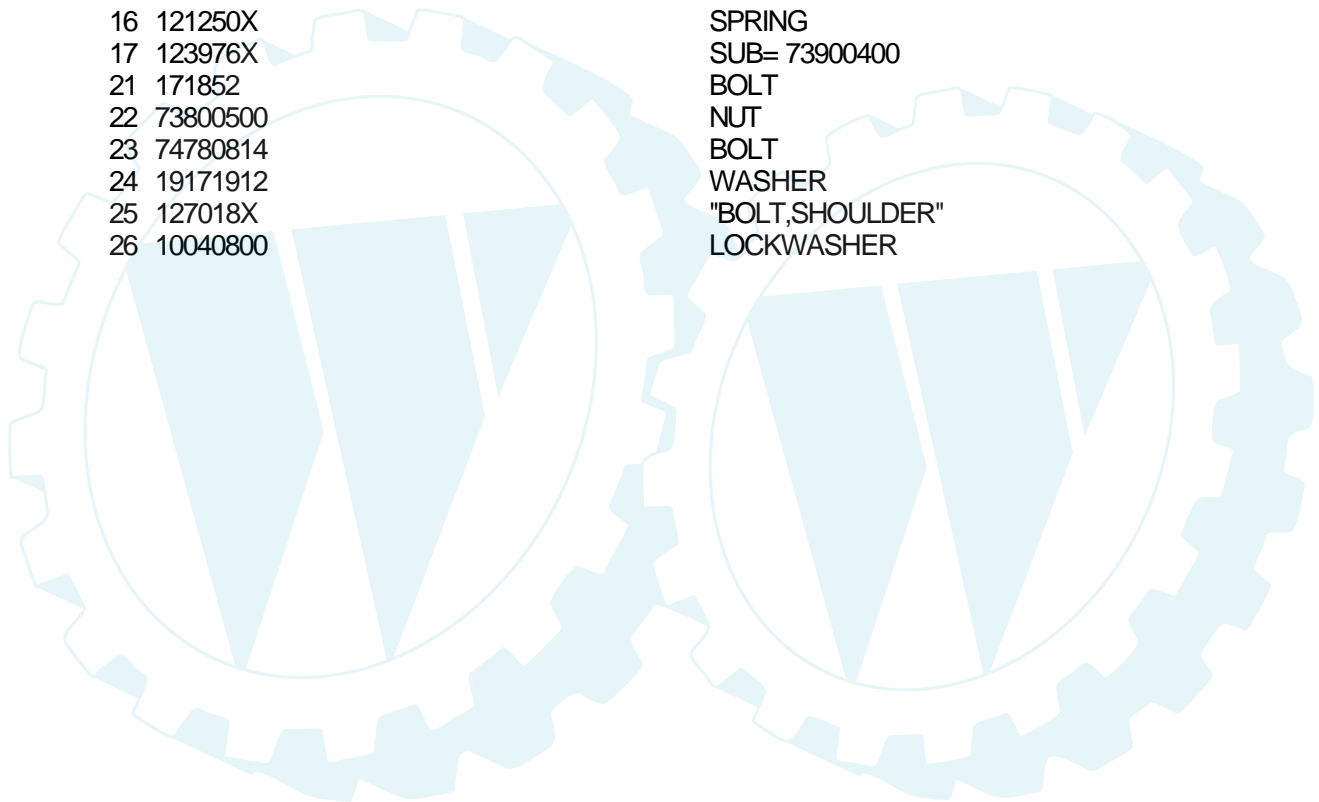



Ref #	Part Number	Qty	Description
1	140044		WHEEL STR AYP BLK
2	154427		AXLE ASM
3	169840		SPINDLE ASM
4	169839		SPINDLE ASM
5	6266H		WASHER .T
6	121748X		WASHER
7	19272016		WASHER
8	12000029		RING
9	3366R		COL. SRTG. BEAR.
10	169832		LINK DRAG
11	10040600		LOCKWASHER
13	136518		SPACER BEARING
15	145212		NUT.HXFLG.LOCK.
17	156546		SHAFT ASM STEERIN
18	57079		THRUST WASHER
19	160395		SUPPORT.SHAFT.STEER
22	165857		SCREW.HX.WSH.HD
23	165851		SHAFT.ASM.PITMAN
25	154406		BRKT-STEERING
26	126847X		BUSHING.DRAGLINK
27	136874		GEAR SECTOR
28	19131416		WASHER
29	17060612		SCREW
30	76020412		COTTER PIN
32	130465		TIE ROD
36	155099		BUSHING.STEERING
37	152927		"SCREW-TT,10-32 FL"
38	140045		CAP STEER AYP
39	19133812		WASHER
40	7810H		GRIPCO NUT
41	100711L		ADAPTER LT
42	145054X428		BOOT.STEERING.DASH.P/L
43	121749X		WASHER
44	153720		EXT SHAFT STEERIN
46	121232X		CAP
47	6855M		ZERK M
51	73800500		NUT
54	74780520		BOLT
62	167902		KIT.STEER.ASM
63	74780616		BOLT
65	160367		"SPACER BRCAE,AXLE"
66	154404		"BEARING-ARM,PITMA"
67	72140618		BOLT RDHD 3/8-16
68	169827		BRACE AXLE
79	19132012		WASHER
80	74950612		BOLT.HX.NYLON3/8-16X3/
82	169835		BRKT SUSP CHASSIS FRT
85	133835		XMAS TREE FASTNER

## TRACTOR - - MODEL NUMBER WEX1242C

### TIRES AND WHEELS

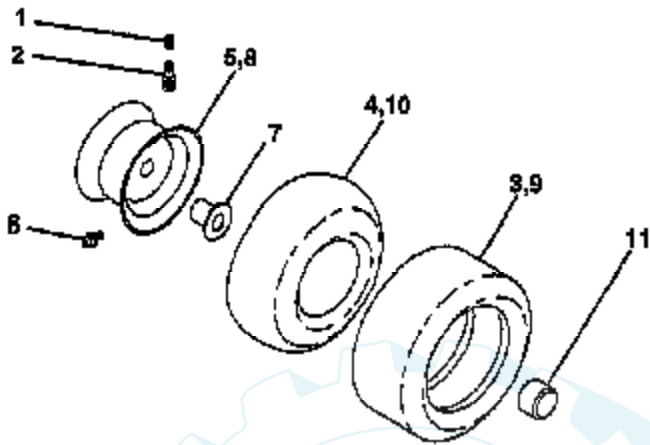

**NOTE:** All component dimensions given in U.S. inches  
1 Inch = 25.4 mm

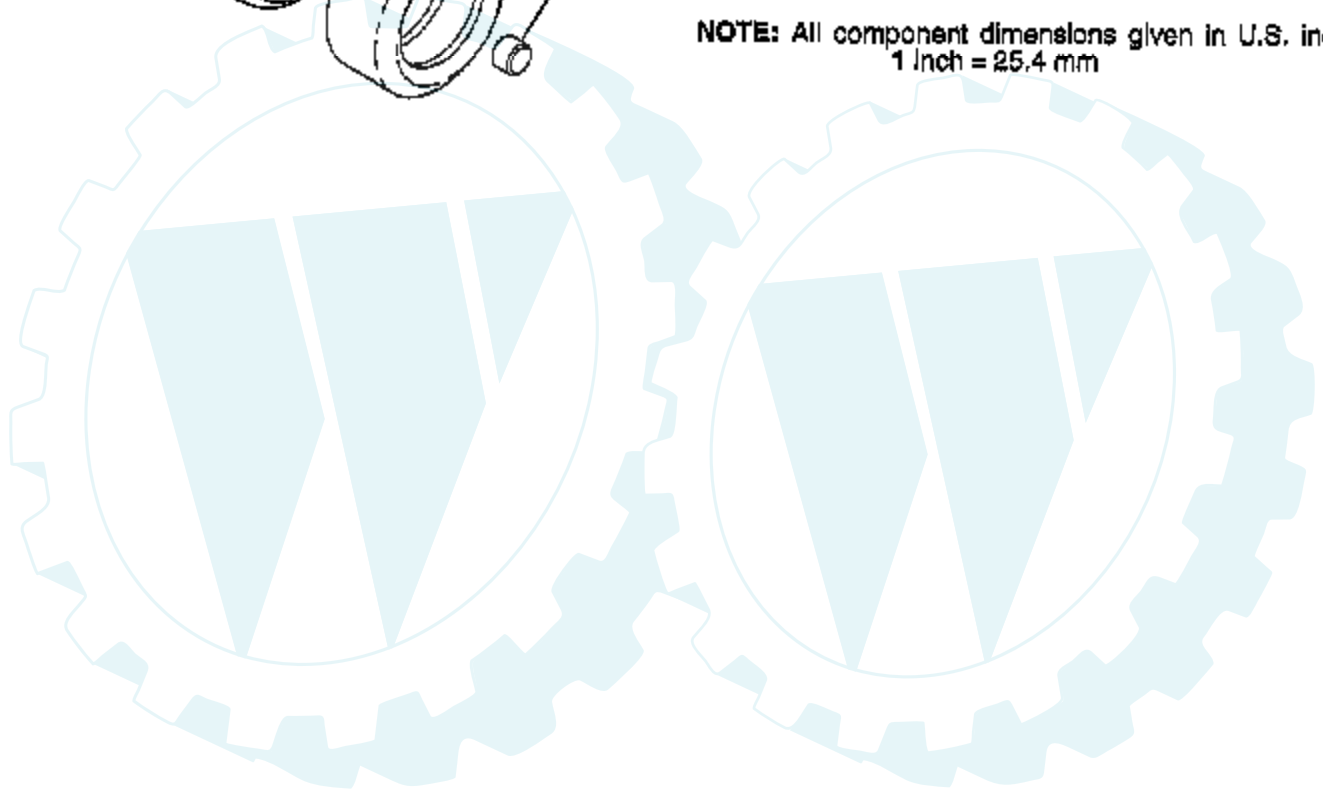

Ref #	Part Number	Qty	Description
1	59192		VALVE CAP
2	65139		VALVE STEM LT
3	106222X		SUB= 122073X
4	59904		TUBE.5.3/4.5/6
5	106732X427		"RIM ASM 6"" FRT"
6	278H		FITTING LT
7	9040H		"FLANGE, BEARING"
8	106108X427		"RIM AS 8"" REAR"
9	124635X		SUB= 126957X
10	7152J		TUBE.18X9.5-8
11	104757X		HUB CAP
	144334		SEALANT.TIRE 10 OZ. TUBE

