

**TRACTOR - - MODEL NUMBER WA17H42STA PRODUCT NO. 954 56 94-31 SCHEMATIC**

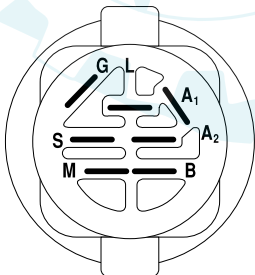
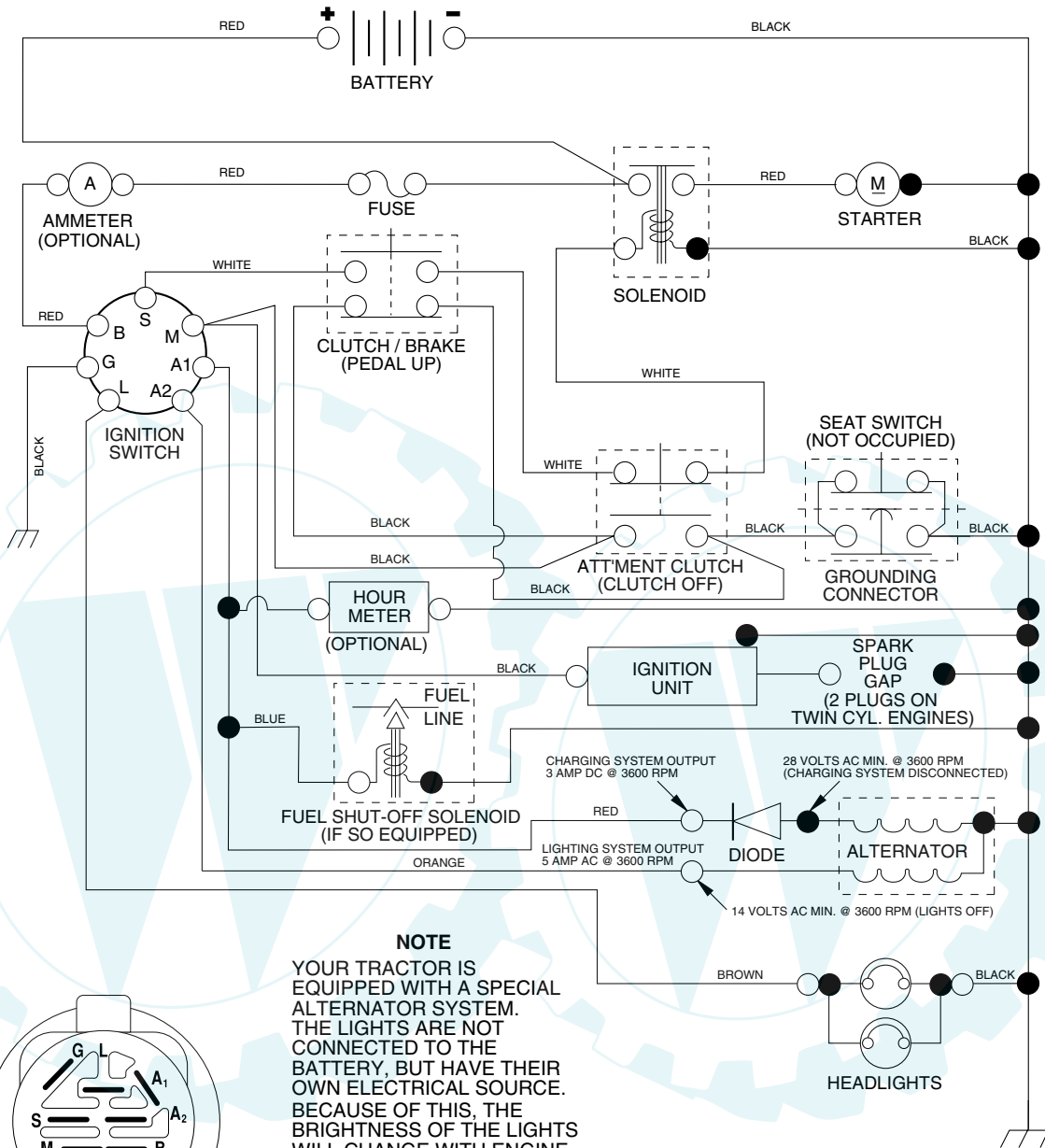

**IGNITION SWITCH**

POSITION	CIRCUIT	"MAKE"
OFF	M+G+A1	NONE
RUN/LIGHT	B+A1	A2+L
RUN	B+A1	NONE
START	B + S + A1	NONE

**NOTE**  
 YOUR TRACTOR IS EQUIPPED WITH A SPECIAL ALTERNATOR SYSTEM. THE LIGHTS ARE NOT CONNECTED TO THE BATTERY, BUT HAVE THEIR OWN ELECTRICAL SOURCE. BECAUSE OF THIS, THE BRIGHTNESS OF THE LIGHTS WILL CHANGE WITH ENGINE SPEED. AT IDLE THE LIGHTS WILL DIM. AS THE ENGINE IS SPEEDED UP, THE LIGHTS WILL BECOME THEIR BRIGHTEST.

**WIRING INSULATED CLIPS**

**NOTE:** IF WIRING INSULATED CLIPS WERE REMOVED FOR SERVICING OF UNIT, THEY SHOULD BE REPLACED TO PROPERLY SECURE YOUR WIRING.

# REPAIR PARTS

TRACTOR - - MODEL NUMBER WA17H42STA PRODUCT NO. 954 56 94-31  
ELECTRICAL

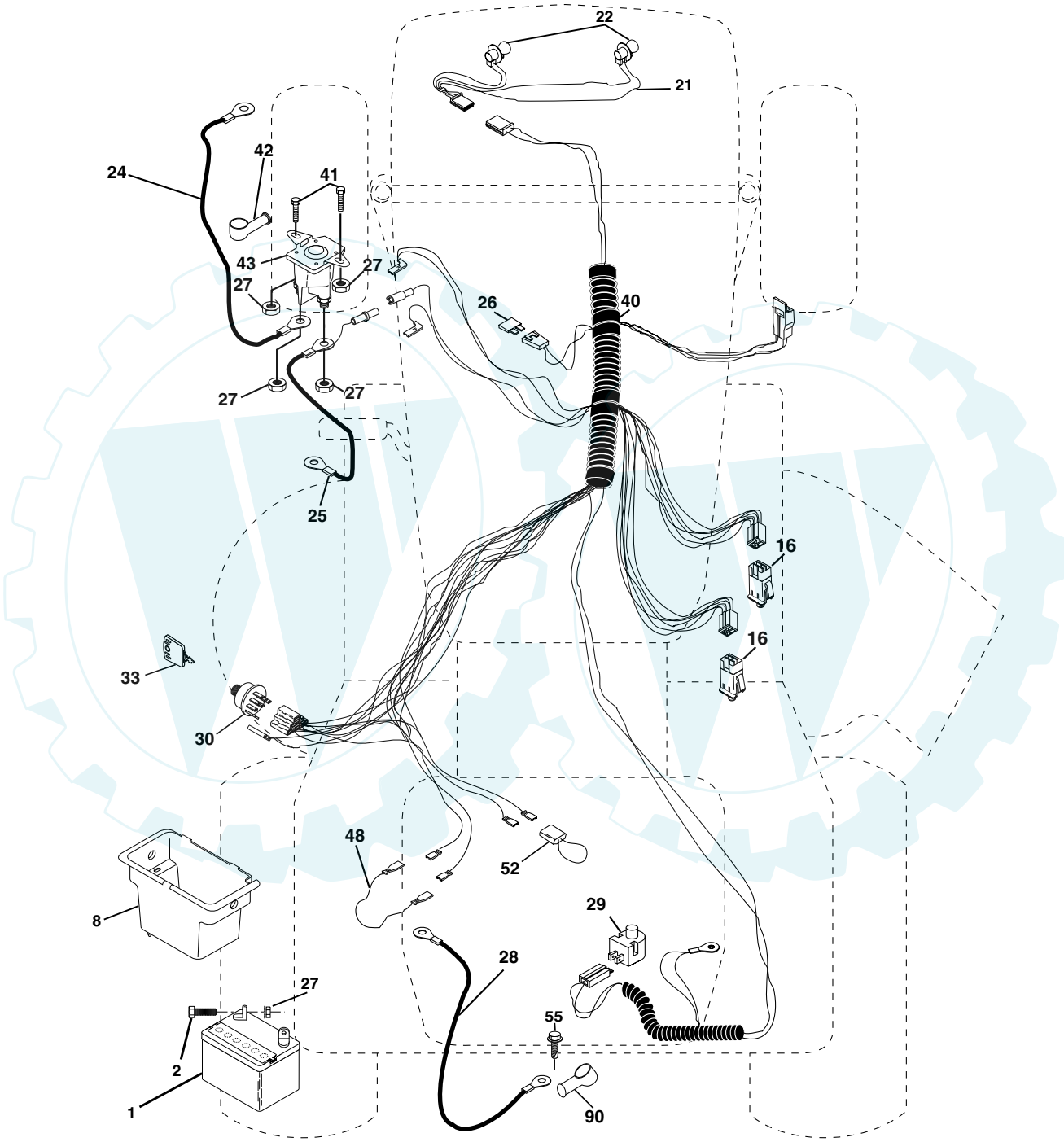

**TRACTOR - - MODEL NUMBER WA17H42STA PRODUCT NO. 954 56 94-31  
ELECTRICAL**

<b>KEY NO.</b>	<b>PART NO.</b>	<b>DESCRIPTION</b>
1	163465	Battery
2	74760412	Bolt Hex Hd 1/4-20unc X 3/4
8	176689	Battery Box
16	176138	Switch Interlock Push-In
21	175688	Harness Socket Light
22	4152J	Bulb, Light # 1156
24	4799J	Cable Battery
25	146147	Cable Battery 6 Ga Red w/16 wire
26	175158	Fuse
27	73510400	Nut Keps Hex 1/4-20 Unc
28	4207J	Cable Ground 6ga 12 black
29	121305X	Switch Plunger Nc Gray
30	175566	Switch Ign
33	140401	Key Ign Molded Generic
40	179720	Harness Ign
41	71110408	Bolt Fin Hex 1/4-20uncx 1/2
42	131563	Cover Terminal Red
43	178861	Solenoid
48	140844	Adapter Ammeter
52	141940	Protection Loop
90	180449	Cover Terminal

**NOTE:** All component dimensions given in U.S. inches  
1 inch = 25.4 mm

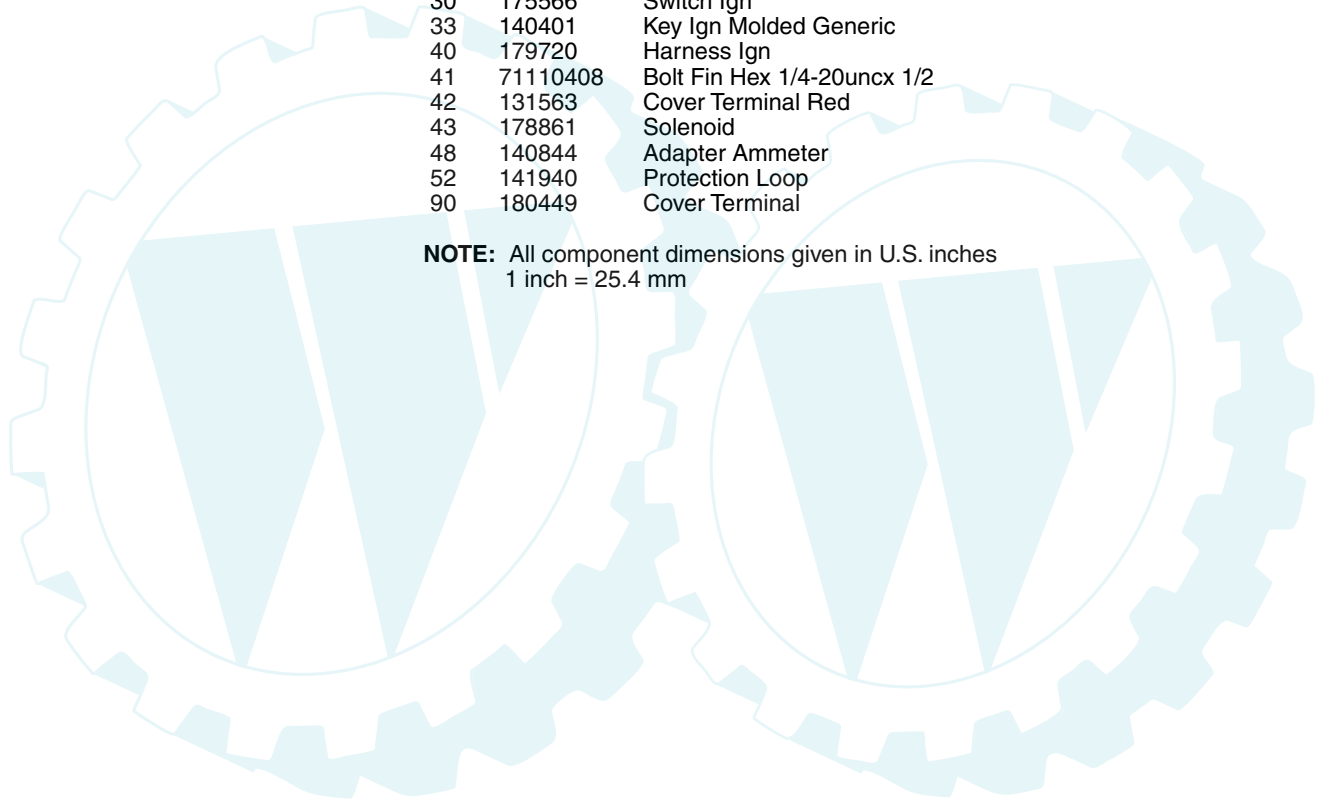

**TRACTOR - - MODEL NUMBER WA17H42STA PRODUCT NO. 954 56 94-31  
CHASSIS AND ENCLOSURES**

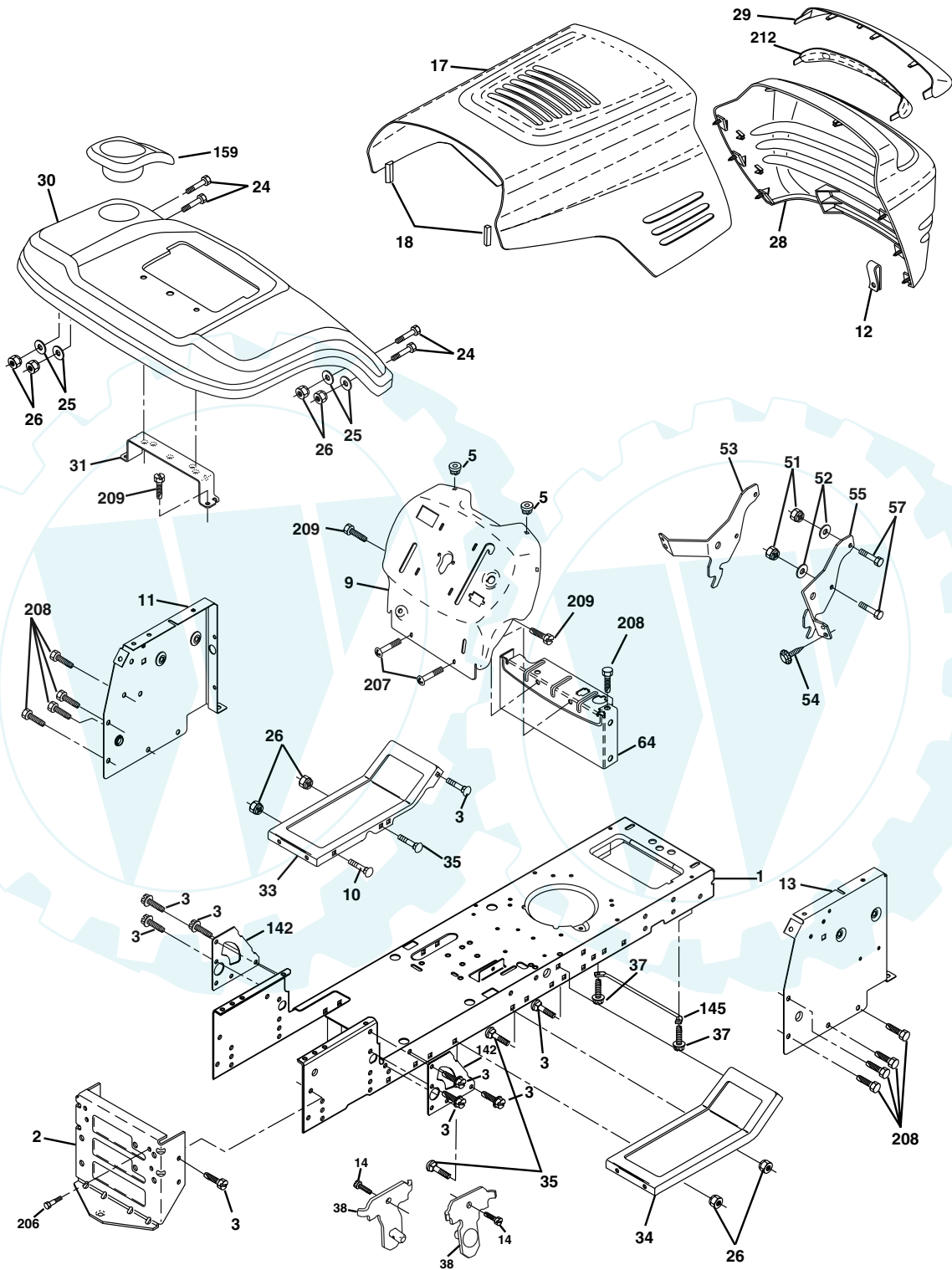

**TRACTOR - - MODEL NUMBER WA17H42STA PRODUCT NO. 954 56 94-31  
CHASSIS AND ENCLOSURES**



<b>KEY NO.</b>	<b>PART NO.</b>	<b>DESCRIPTION</b>
1	174619	Chassis
2	176554	Drawbar
3	17060612	Screw 3/8-16x.75
5	155272	Bumper Hood/Dash
9	168336X010	Dash P/L
10	72140608	Bolt Carriage 3/8-16 x 1
11	174996	Panel Dash Lh
12	145660	Clip Tinnerman
13	172106	Panel Dash Rh
14	17490608	Screw Thdrol 3/8-16 x 1-1/4
17	144983X603	Hood W/Side Louvers
18	184921	Bumper Hood Large
24	74780616	Bolt Fin Hex 3/8-16 x 1 Gr 5
25	19131312	Washer 13/32 X 13/16 X 12 Ga
26	73800600	Nut Lock Hex W/Ins 3/8-16 Unc
28	178987X428	Grille LT/PL
29	155217X599	Lens
30	169470X603	Fender Footrest STLT Pnt
31	136619	Bracket Support Fender
33	179716X603	Footrest Pnt Lh
34	179717X603	Footrest Pnt Rh
35	72110606	Bolt Rdhd Sht Sqnk 3/8-16 x 3/4
37	17490508	Screw Thdrol 6/16-18 x 1/2 TYT
38	175710	Bracket Asm. Pivot Mower Rear
51	73800400	Nut Lock Hex W/Ins 1/4-20
52	19091416	Washer 9/32 x 7/8 x 16 Ga.
53	145201	Bracket Grille Lh
54	161464	Screw Hex Wshd 8-18 x 7/8
55	145202	Bracket Grille Rh
57	74780412	Bolt Hex 1/4-20 x 3/4
64	154798	Dash Lower STLT
142	175702	Plate Reinforcement STLT
145	156524	Rod Pivot Chassis/Hood
159	169473X428	Cupholder
206	170165	Bolt Shoulder 5/16-18
207	17670508	Screw Thdrol 5/16-18 x 1/2
208	17670608	Screw Thdrol 3/8-16 x 1/2
212	165919	Insert Lens Reflect
--	5479J	Plug

**NOTE:** All component dimensions given in U.S. inches  
1 inch = 25.4 mm



**TRACTOR - - MODEL NUMBER WA17H42STA PRODUCT NO. 954 56 94-31  
GROUND DRIVE**

KEY NO.	PART NO.	DESCRIPTION	KEY NO.	PART NO.	DESCRIPTION
1	-----	Transaxle Hydro Gear 322-0510 (Order Parts From Transaxle Manufacturer)	70	134683	Guide Belt
8	165619	Rod Shift Hydro LT	71	169183	Strap Torque Lh Hydro
10	76020416	Pin Cotter 1/8 x 1 CAD	73	169182	Strap Torque Rh Hydro
14	10040400	Washer Lock Hvy Helical	74	137057	Spacer, Axle
15	74490544	Bolt, Hex FLGHD 5/16-18 Gr. 5	75	121749X	Washer 25/32 x 1-1/4 x 16 Gauge
16	73800500	Nut Lock Hex W/Ins 5/16-18unc P	76	12000001	E-Ring
19	73800600	Nut Lock Hex W/Wsh 3/8-16 Unc	77	123583X	Key, Square
21	140845	Knob, Round 1/2-13	78	121748X	Washer 25/32 x 1-5/8 x 16 Gauge
22	169498	Rod, Brake Hydro	81	165596	Shaft Asm. Cross Hydro
24	73350600	Nut	82	123782X	Spring Torsion T/A
25	106888X	Spring, Brake Rod	83	19171216	Washer 17/32 x 3/4 x 16 Ga.
26	19131316	Washer	84	169843	Link Transaxle
27	76020412	Pin Cotter 1/8 x 3/4 CAD.	89	169373X428	Console, Hydro
28	175765	Rod, Parking Brake	95	170201	Control Asm Bypass Hydro
29	71673	Cap, Parking Brake	96	4497H	Retainer Spring 1" Zinc/Cad
30	174973	Bracket, Transaxle	103	73940800	Nut Hex Jam Toplock 1/2-20 Unf
32	74760512	Bolt Hex Hd 5/16-18 Unc x 3/4	105	19171616	Washer 17/32 x 1 x 16 Ga.
34	175578	Shaft, Foot Pedal	116	72140608	Bolt Rdhd Sq Neck 3/8-16 x 1
35	120183X	Bearing, Nylon	120	73900600	Nut Lock Flg 3/8-16
36	19211616	Washer	150	175456	Spacer Retainer
37	1572H	Pin, Roll	151	19133210	Washer 13/32 x 2 x 10 Ga.
38	179114	Pulley, Flat Composite	156	166002	Washer Srrted 5/16 ID x 1.125
39	74760648	Bolt Fin Hex 3/8-16 x 3	158	165589	Bracket Shift Mount
41	175556	Keeper, Belt Idler	159	165494	Hub Tapered Flange Shift Lt
47	127783	Pulley, Idler, V-Groove	161	72140406	Bolt Rdhd Sqnk 1/4-20 x 3/4 Gr 5
48	154407	Bellcrank Clutch Grnd Drv STL	162	73680400	Nut Crownlock 1/4-20 Unc
49	123205X	Retainer, Belt	163	74780416	Bolt Hex Fin 1/4-20 Unc x 1 Gr 5
50	72110612	Bolt Carr. SH 3/8-16 x 1-1/2 Gr. 5	164	19091010	Washer 5/8 x .281 x 10 Ga
51	73680600	Nut Crownlock 3/8-16 UNC	165	165623	Bracket Pivot Lever
52	73680500	Nut Crownlock 5/16-18 UNC	166	166880	Screw 5/16-18 x 5/8
53	105710X	Link, Clutch	168	165492	Bolt Shoulder 5/16-18 x .561
55	105709X	Spring, Return, Clutch	169	165580	Plate Fastening Lt
56	17060620	Screw 3/8-16 x 1-1/4	197	169613	Nyliner Snap-In 5/8" ID
57	140294	V-Belt, Ground Drive	198	169593	Washer Nyl 7/8 ID x .105
59	169691	Keeper, Center Span	199	169612	Bolt Shoulder 5/16-18 Unc
61	17120614	Screw 3/8-16 x .875	200	72140508	Bolt Rdhd Sqnk 5/16-18 Unc x 1
62	8883R	Cover, Pedal	202	72110614	Bolt RDHD 3/8-16 x 1-3/4 Gr 5
63	175410	Pulley, Engine	212	145212	Nut Hex Flg Lock
64	71170764	Bolt, Hex	250	17060612	Screw Thdrol. 3/8-16 x .75
65	10040700	Washer			
66	154778	Keeper Belt Engine			
69	142432	Screw			

**NOTE:** All component dimensions given in U.S.  
inches 1 inch = 25.4 mm



**TRACTOR - - MODEL NUMBER WA17H42STA PRODUCT NO. 954 56 94-31  
STEERING ASSEMBLY**

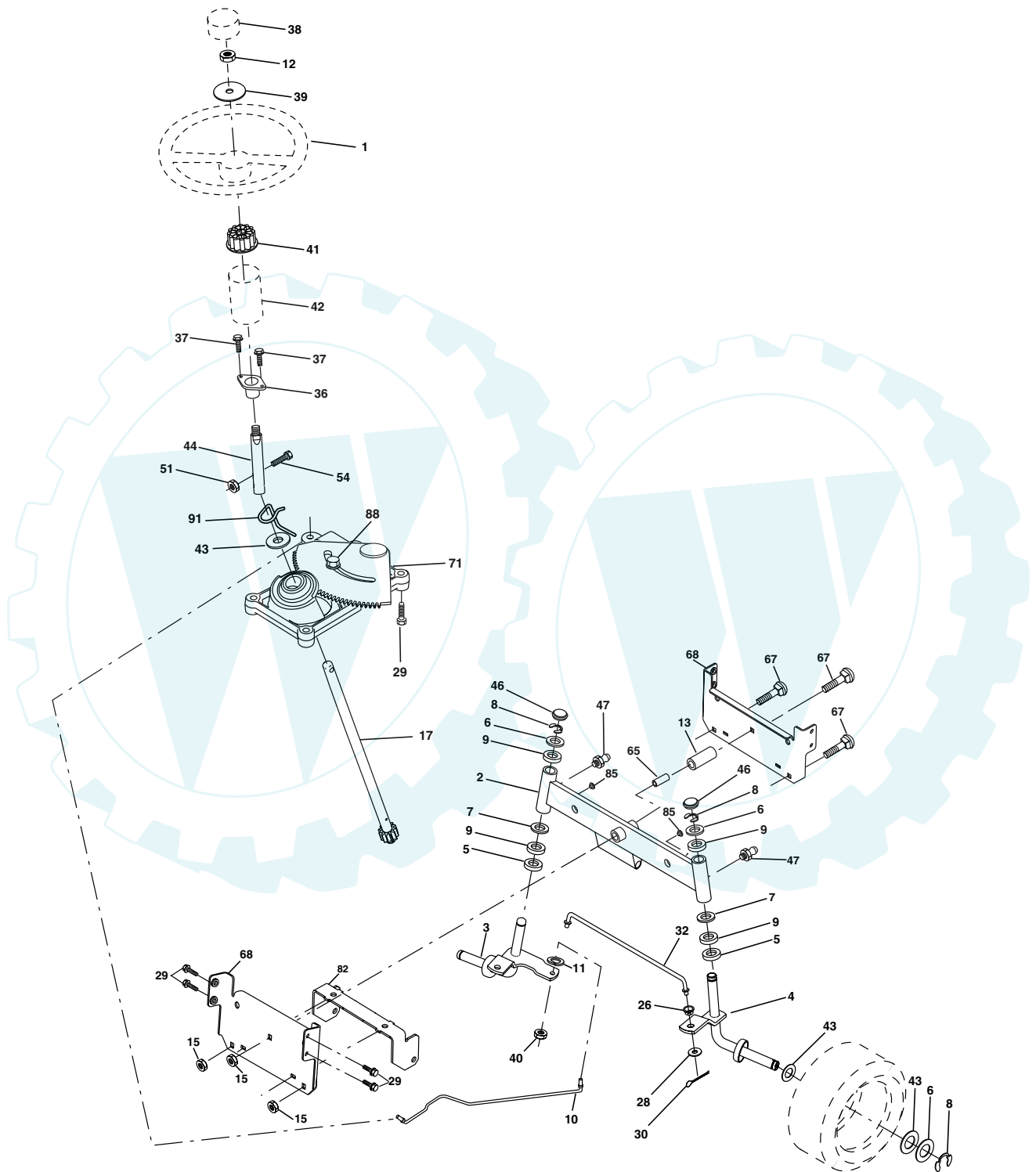



**TRACTOR - - MODEL NUMBER WA17H42STA PRODUCT NO. 954 56 94-31  
STEERING ASSEMBLY**

<b>KEY NO.</b>	<b>PART NO.</b>	<b>DESCRIPTION</b>
1	184704X428	Wheel Steering
2	175131	Axle Asm Cast Iron LT
3	169840	Spindle Asm LH
4	169839	Spindle Asm RH
5	6266H	Bearing Race Thrust Harden
6	121748X	Washer 25/32 X 1-5/8 X 16 Ga
7	19272016	Washer 27/32 x 1-1/4 x 16 Ga
8	12000029	Ring Klip #t5304-75
9	3366R	Bearing Col. Strg.
10	175121	Link Drag
11	10040600	Washer Lock Hvy Hlcl Spr 3/8
12	73940800	Nut Hex Jam Toplock 1/2-20 Unf
13	136518	Spacer Brg. Axle Front
15	145212	Nut Hex Flange Lock
17	180641	Shaft Asm. Steering
26	126847X	Bushing Link Drag
28	19131416	Washer 13/32 x 7/8 x 16 Ga.
29	17060612	Screw 3/8-16 x .75
30	76020412	Pin Cotter 1/8 x 3/4
32	130465	Rod Tie
36	155099	Bushing Strg
37	152927	Screw
38	159946X428	Insert Cap Strg Wh Au
39	19182411	Washer
40	7810H	Lock nut
41	159945	Adaptor Wheel Strg
42	145054X428	Boot Steering Dash
43	121749X	Washer 25/32 X 1 1/4 X 16 Ga
44	180640	Extension Steering Shaft
46	121232X	Cap Spindle Fr Top Blk
47	183226	Fitting Grease
51	73540400	Nut Crownlock 1/4-28
54	71130420	Bolt Hex 1/4-28 Unf x 1-1/4 Gr. 8
65	160367	Brace Axle
67	72140618	Bolt Rdhd Sq 3/8-16 Unc x 2-1/4
68	169827	Axle, Brace
71	175146	Steering Asm.
82	169835	Bracket Susp. Chassis Front
85	133835	Fastner Christmas Tree
88	175118	Bolt Shoulder 7/16-20 Unc
91	175553	Clip Steering

**NOTE:** All component dimensions given in U.S. inches  
1 inch = 25.4 mm

**TRACTOR - - MODEL NUMBER WA17H42STA PRODUCT NO. 954 56 94-31  
ENGINE**

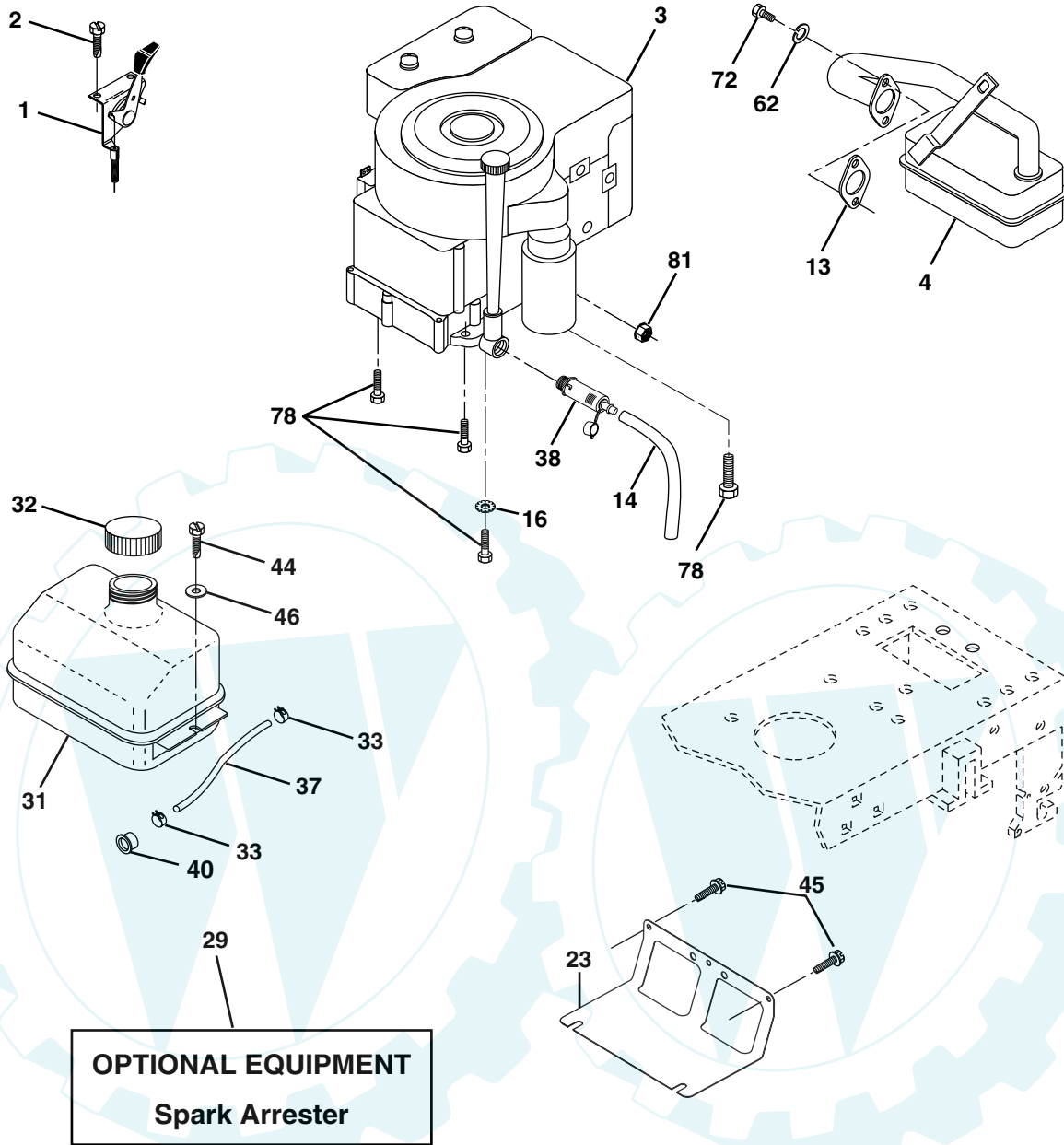

KEY NO.	PART NO.	DESCRIPTION
1	170551	Control Th/ch Flag
2	17720408	Screw Hex Thd Cut 1/4-20 x 1/2
3	-----	Engine, Briggs Model 31G777 (Order Parts From Engine Manufacturer)
4	137352	Muffler
13	165291	Gasket Eng
14	148456	Tube Drain Oil Easy
16	11050600	Washer Lock Ext Tooth 3/8
23	169837	Shield Brn/Dbr Guard
29	137180	Kit Spark Arrestor (Flat Scrn)
31	109202X	Tank Fuel Front
32	140527	Cap Asm Fuel W/sym Vented

KEY NO.	PART NO.	DESCRIPTION
33	123487X	Clamp Hose Black
37	137040	Line Fuel 20"
38	181654	Plug Drain Oil Easy
40	124028X	Bushing Snap Nyl Blk Fuel Line
44	17670412	Screw Hexwsh Thdrol 1/4-20x3/4
45	17000612	Screw Hexwsh Thdr 3/8-16 x 3/4
46	19091416	Washer 9/32 X 7/8 X 16 Ga
62	10040500	Washer Lock Hvy Hlcl Spr 5/16
72	71070512	Screw Hex Hd Cap 5/16-18 x 3/4
78	17060620	Screw 3/8-16x1-1/4
81	73510400	Nut Keps Hex 1/4-20 UNC

**NOTE:** All component dimensions given in U.S. inches  
1 inch = 25.4 mm

**TRACTOR - - MODEL NUMBER WA17H42STA PRODUCT NO. 954 56 94-31  
SEAT ASSEMBLY**

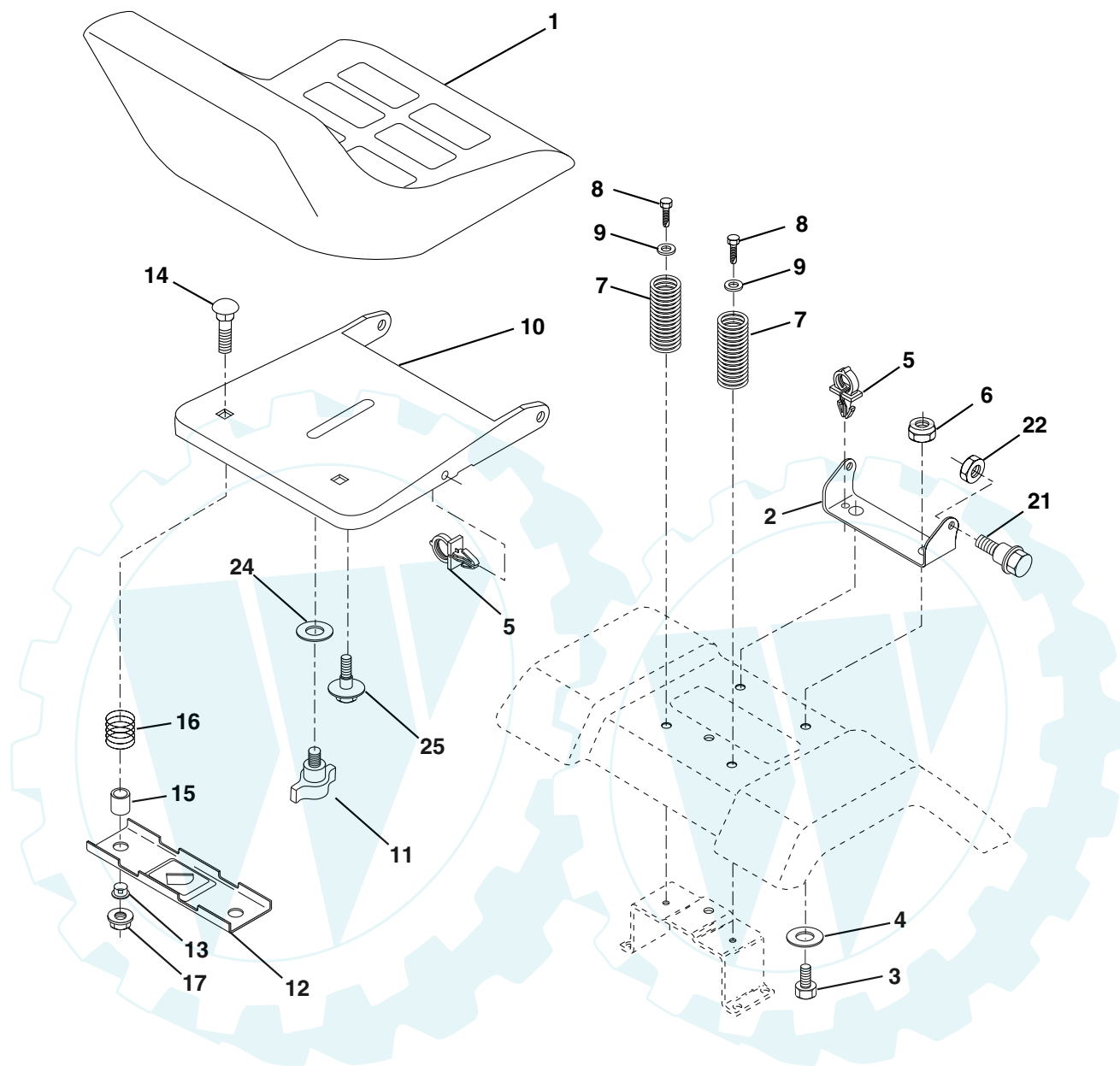

KEY PART NO.	PART NO.	DESCRIPTION
1	140117	Seat
2	140551	Bracket Pivot Seat 8 720
3	71110616	Bolt Fin Hex 3/8-16 Unc X 1
4	19131610	Washer 13/32 X 1 X 10 Ga
5	145006	Clip Push-In
6	73800600	Nut Hex w/Ins. 3/8-16 Unc
7	124181X	Spring Seat Cprsn 2 250 Blk Zi
8	17000616	Screw 3/8-16 X 1.5
9	19131614	Washer 13/32 X 1 X 14 Ga.
10	182493	Pan Seat
11	166369	Knob Seat
12	121246X	Bracket Mounting Switch

KEY PART NO.	PART NO.	DESCRIPTION
13	121248X	Bushing Snap Blk Nyl 50 Id
14	72050412	Bolt Rdhd Sqnk 1/4-20x1-1/2
15	134300	Spacer Split 28x 88
16	121250X	Spring Cprsn
17	123976X	Nut Lock 1/4 Lge Flg Gr 5 Zinc
21	171852	Bolt Shoulder 5/16-18 Unc
22	73800500	Nut Hex Lock W/Ins 5/16-18
24	19171912	Washer 17/32 X 1-3/16 X 12 Ga.
25	127018X	Bolt Shoulder 5/16-18 X 62

**NOTE:** All component dimensions given in U.S. inches  
1 inch = 25.4 mm

**TRACTOR - - MODEL NUMBER WA17H42STA PRODUCT NO. 954 56 94-31  
DECALS**

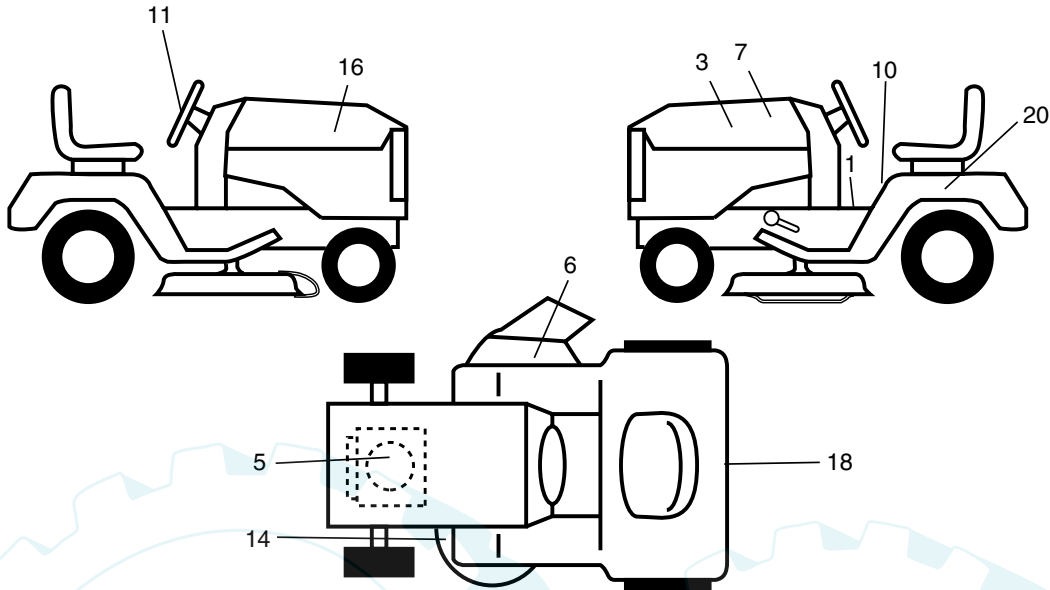

KEY PART NO.	PART NO.	DESCRIPTION
1	156811	Decal Oper
3	184954	Decal Hood LH
5	180703	Decal HP Engine
6	179128	Decal Deck "B" 42"
7	185412	Decal Repl. Parts
10	156439	Decal Fender Danger E/F
11	184943	Decal Ins Strg Whl
14	160396	Decal V-Belt Schematic
16	184953	Decal Hood Rh

KEY PART NO.	PART NO.	DESCRIPTION
18	184944	Decal Fender
20	145005	Decal Bat Dan/Psn
--	184961	Decal Chassis
--	179768X428	Pad Footrest LH
--	179769X428	Pad Footrest RH
--	138311	Decal Handle Lft Height Adjust
--	169210	Decal By Pass
--	181249	Decal Footrest
--	184544	Manual Owner's (English)
--	184545	Manual Owner's (Spanish)

**WHEELS & TIRES**

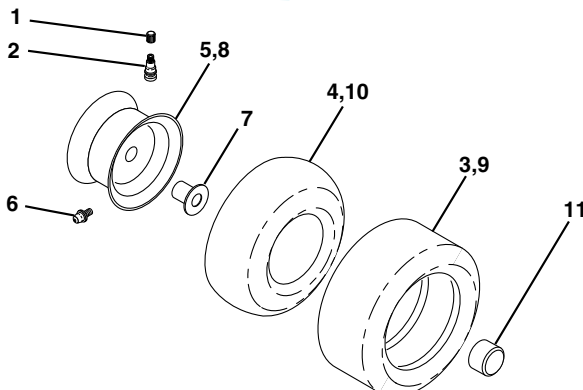

KEY PART NO.	PART NO.	DESCRIPTION
1	59192	Cap Valve Tire
2	65139	Stem Valve
3	106222X	Tire F T 15 X 6 0 - 6 Service
4	59904	Tube Front (Service Item Only)
5	106732X417	Rim Asm 6"front Service
6	278H	Fitting Grease (Front Wheel Only)
7	9040H	Bearing Flange (Front Wheel nly)
8	106108X417	Rim Asm 8"rear Service
9	106268X	Tire R T 20x10-8 Service
10	7152J	Tube Rear (Service Item Only)
11	104757X421	Cap Axle Blk 1 50 X 1 00
--	144334	Sealant, Tire ( 10 oz. Tube)

**NOTE:** All component dimensions given in U.S. inches  
1 inch = 25.4 mm

**TRACTOR - - MODEL NUMBER WA17H42STA PRODUCT NO. 954 56 94-31  
LIFT ASSEMBLY**

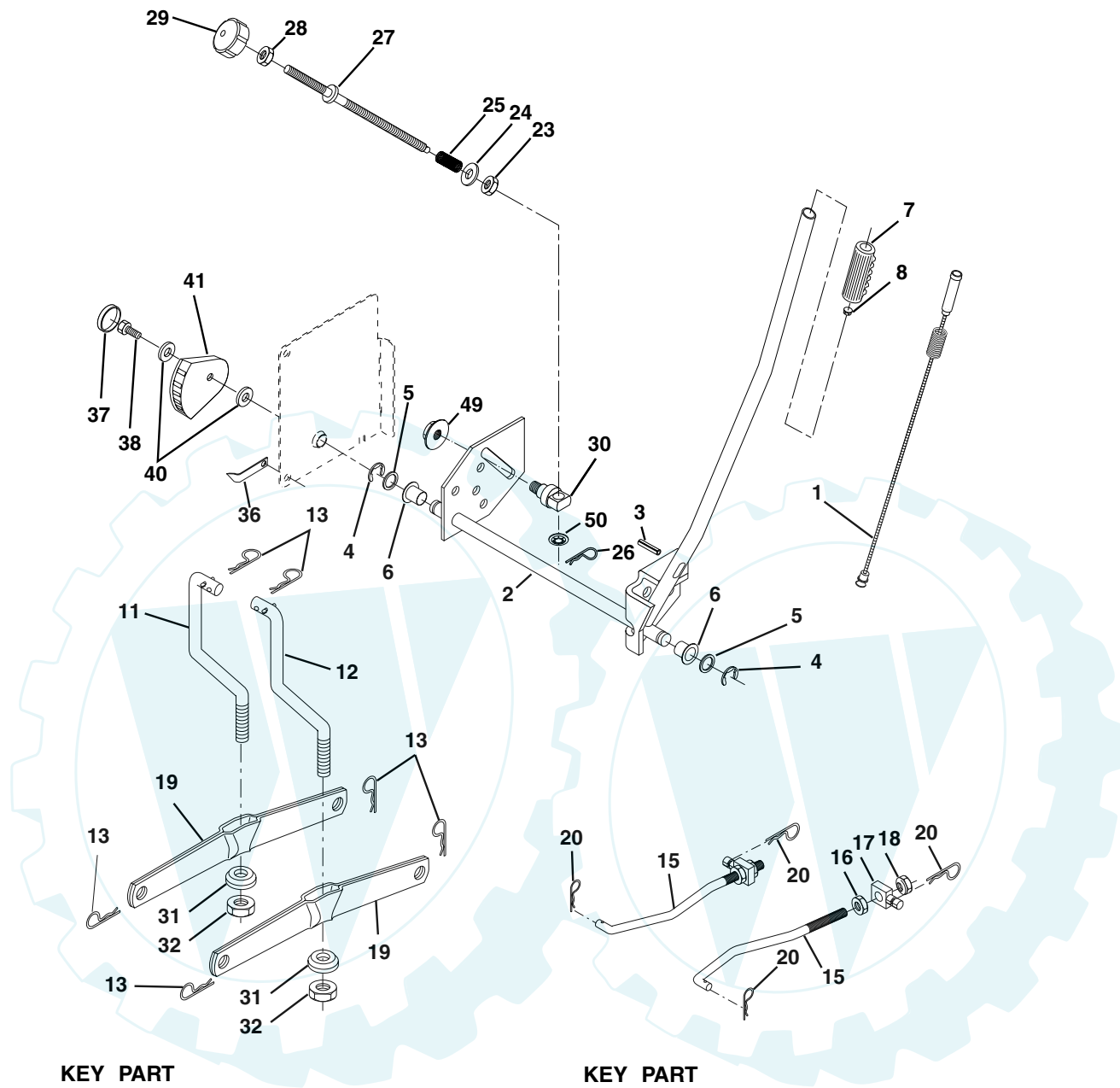

KEY NO.	PART NO.	DESCRIPTION
1	159460	Wire Asm Inner/Sprg W/plunger LT
2	159471	Shaft Asm Lift RH w/Inf
3	105767X	Pin Groove 1 500 Zinc
4	12000002	E Ring #5133-62
5	19211621	Washer 21/32 X 1 X 21 Ga
6	120183X	Bearing Nylon Blk 629 Id
7	109413X	Grip Handle
8	124526X	Button Plunger
11	139865	Link Lift LH Fixed Length
12	139866	Link Lift RH Fixed Length
13	4939M	Retainer Spring
15	173288	Link Front
16	73350800	Nut Jam Hex 1/2-13 Unc
17	175689	Trunnion
18	73800800	Nut Lock W/Wsh 1/2-13 Unc
19	139868	Arm Suspension Rear
20	163552	Retainer Spring
23	110807X	Nut Special

KEY NO.	PART NO.	DESCRIPTION
24	19131016	Washer 13/32 X 5/8 X 16 Ga
25	2876H	Spring 2-1/8"
26	169484	Retainer Clip
27	126971X	Rod Adj Lift Zinc 7.49 Wrk Lg
28	73350600	Nut Hex Jam 3/8-16 Unc
29	138057	Knob Inf 3/8-16 Unc Blk W/sym
30	150233	Trunnion Infin Height
31	169865	Bearing Pvt Lift
32	73540600	Nut Crownlock 3/8 - 24
36	155097	Pointer Height Indicator
37	123935X	Plug Hole Blk 1.485/1.515 Dia.
38	17060516	Screw 5/16-18 x 1
40	19112410	Washer 11/32 x 1-1/2 10 Ga.
41	155098	Indicator Height STLT
49	145212	Nut Hex Flange Lock
50	110452X	Nut PUSh Phos & Oi

**NOTE:** All component dimensions given in U.S. inches  
1 inch = 25.4 mm

TRACTOR - - MODEL NUMBER WA17H42STA PRODUCT NO. 954 56 94-31  
MOWER DECK

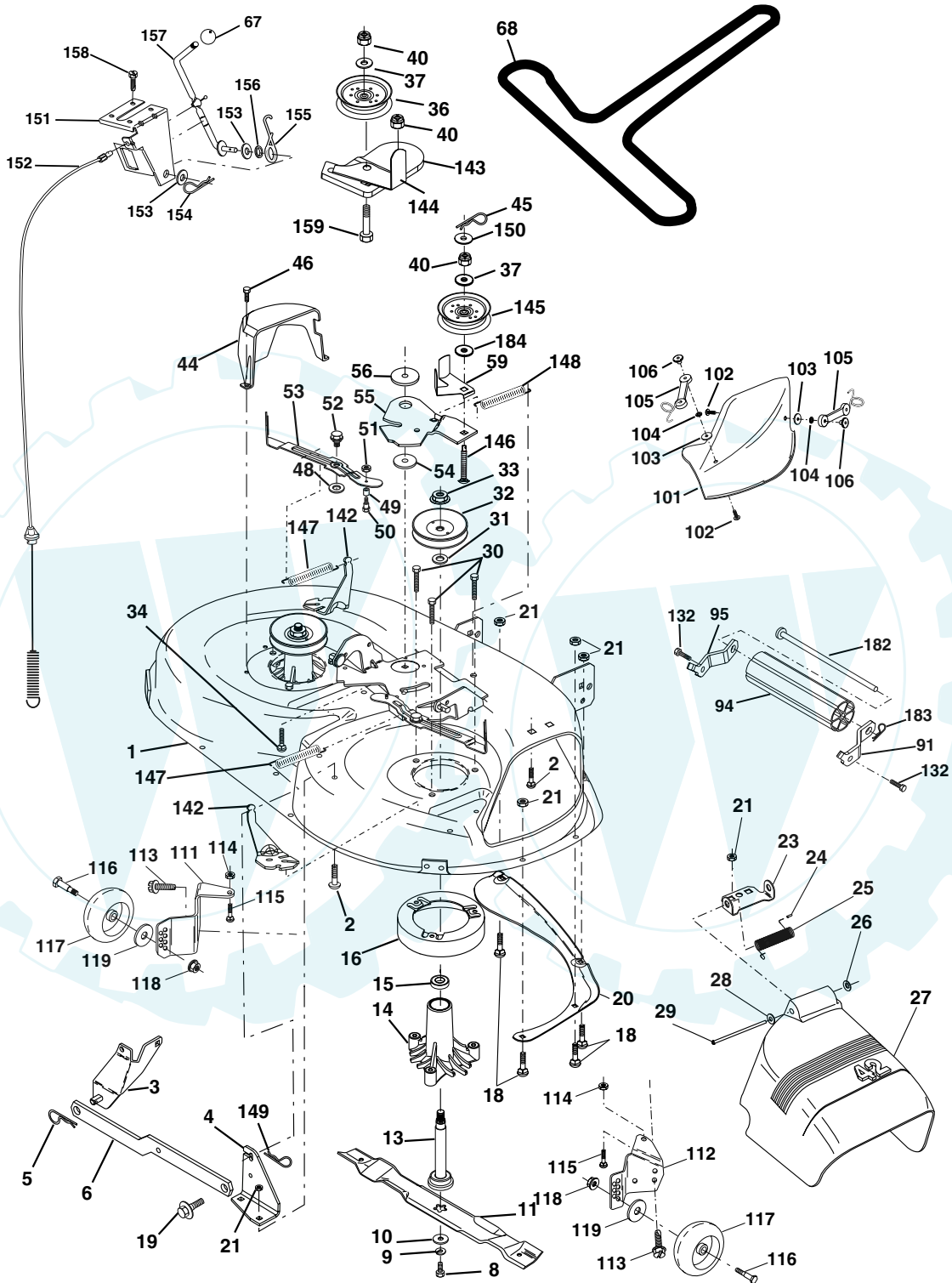



**TRACTOR - - MODEL NUMBER WA17H42STA PRODUCT NO. 954 56 94-31  
MOWER DECK**

KEY NO.	PART NO.	DESCRIPTION	KEY NO.	PART NO.	DESCRIPTION
1	165892	Mower Deck Assembly, 42"	67	106932X	Knob
2	72140506	Bolt	68	144959	V-Belt, 42" Mower
3	138017	Bracket Asm Fr. Sway Bar 3/42	101	136420	Mulcher Cover
4	165460	Bracket Asm Deck 42" Sway Bar	102	71081010	Screw
5	4939M	Retainer Spring	103	19061216	Washer, Flat
6	178024	Bar Sway Deck	104	10071000	Washer, Lock
8	850857	Bolt 3/8-24 x 25 Grade 8 patched	105	160793	Latch Assembly
9	10030600	Washer, Lock	106	2029J	Nut, Weld
10	140296	Washer, Hardened	111	179292	Bracket, Gauge, Wheel LH
11	134149	Blade, Mulching 42"	112	179293	Bracket, Gauge, Wheel RH
	138498	Blade Mower 42" Hi-Lift	113	17060510	Screw 3/8-16 x .625
13	137645	Shaft Assembly, Mandrel, Vented	114	73510500	Nut, Keps 5/16 - 18 UNC
14	128774	Housing, Mandrel, Vented	115	72110505	Bolt, Carriage 5/16-18 x 5/8
15	110485X	Bearing, Ball, Mandrel	116	4898H	Bolt, Shoulder
16	174493	Stripper, Mandrel Deck	117	165746	Wheel, Gauge
18	72140505	Bolt, Carriage 5/16-18 x 5/8	118	73930600	Nut Centerlock 3/8-16
19	132827	Bolt, Shoulder	119	19121414	Washer 3/8 x 7/8 x 14 Ga.
20	159770	Baffle, Vortex	142	165890	Arm Spring Brake Mower
21	73680500	Nut	143	157109	Bracket Arm Idler 42"
23	177563	Bracket, Deflector Mower 42"	144	158634	Keeper Belt 42" Clutch Cable
24	105304X	Cap, Sleeve 80 x 112 Blk Mower	145	165888	Pulley Idler Flat
25	123713X	Spring, Torsion, Deflector 2 52	146	171977	Bolt Carriage Idler
26	110452X	Nut, Push Phos & Oil	147	131335	Spring Extension
27	130968X428	Shield, Deflector 42" Blk	148	169022	Spring Return Idler
28	19111016	Washer 11/32 x 5/8 x 16 Gauge	149	165898	Retainer Spring Yellow
29	131491	Rod, Hinge 42" 6 75 W/G	150	19091216	Washer 9/32 x 3/4 x 16 Ga.
30	173984	Screw Thdrol Washer Head	151	169670	Bracket Clutch Cable
31	129963	Washer, Spacer Mower Vented	152	169676	Clutch Cable 42"
32	153535	Pulley, Mandrel	153	169674	Washer Flat 3/8" Type B
33	178342	Nut, Toplock 9/16 Flange	154	169675	Spring Retainer
34	72110614	Bolt	155	169671	Spring Retention LVR CLTCH CAB
36	131494	Pulley, Idler, Flat	156	169672	Spacer Clutch Cable
37	19131316	Washer 13/32 x 13/16 x 16 Gauge	157	169669	Rod Clutch Cable 3/8"
40	73680600	Nut	158	17720408	Screw Hex Thd Cut 1/4-20 x 5/8
44	140088	Guard, Mandrel, LH	159	72140614	Bolt Rdhd Sqn 3/8-16 UNC x 1- 3/4
45	4497H	Retainer	184	19131410	Washer 13/32 x 7/8 x 10 Ga.
46	137729	Screw, Thdrol 1/4-20 x 5/8 T	--	130794	Mandrel Assembly (Includes Housing, Shaft and Shaft Hard ware Only-Pulley Not Included)
48	133944	Washer, Hardened	--	171491	Replacement Mower, Complete
49	174284	Roller Assembly, Cam Follower			
50	131340	Bolt, Shoulder #10-24 Grade 5			
51	69180	Locknut			
52	139888	Bolt, Shoulder 5/16-18 UNC			
53	131845	Arm Assembly, Pad, Brake			
54	178515	Washer, Hardened			
55	155046	Arm, Idler			
56	165723	Spacer, Retainer			
59	141043	Guard TUV Idler			

**NOTE:** All component dimensions given in U.S.inches  
1 inch = 25.4 mm