

REPAIR PARTS

www.ersatzteil-service.de

TRACTOR -- MODEL NUMBER UM1236E

ELECTRICAL

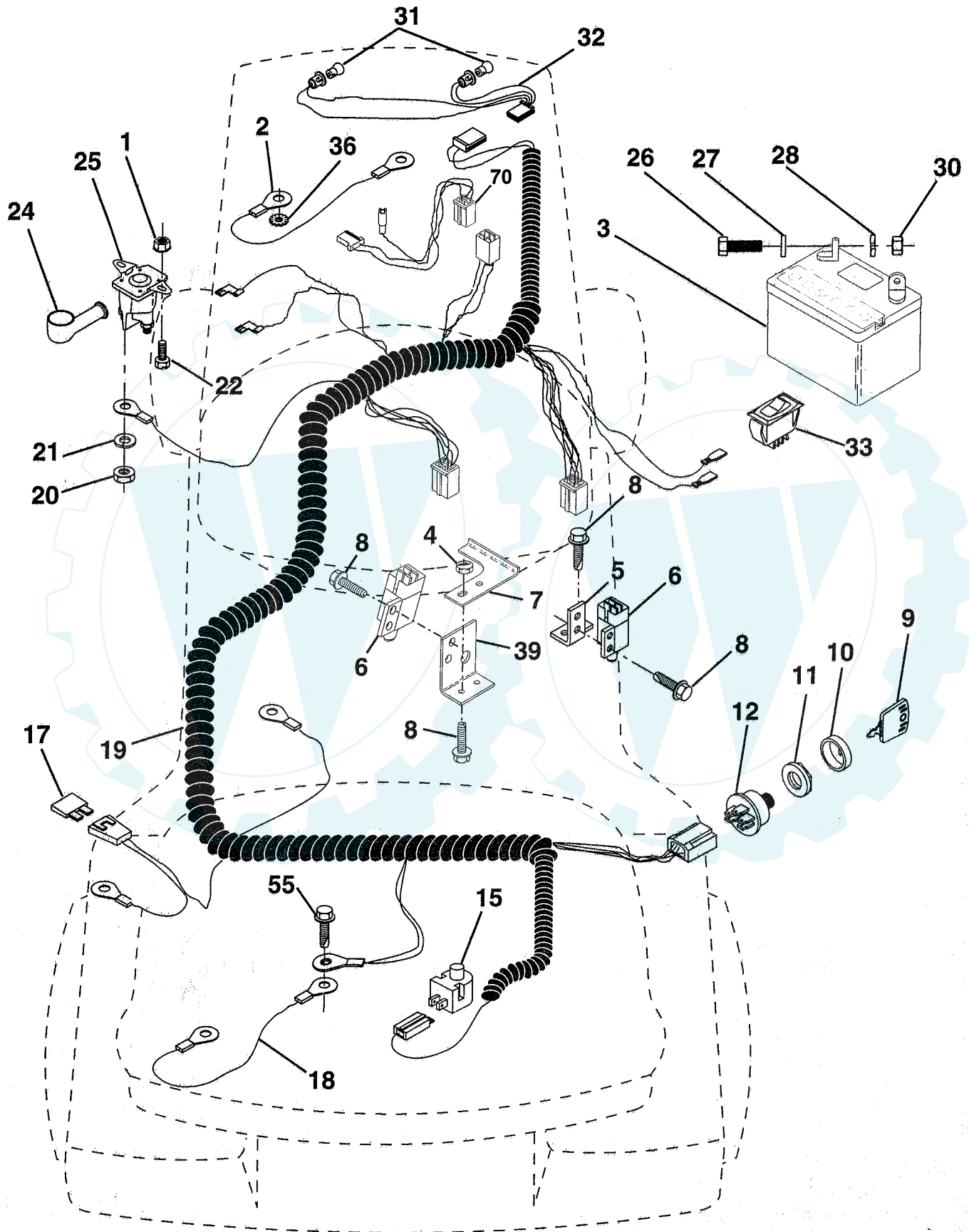

REPAIR PARTS

TRACTOR - - MODEL NUMBER UM1236E

ELECTRICAL

KEY NO.	PART NO.	DESCRIPTION
1	73640400	Nut, Hex, Keps 1/4-20 UNC
2	108423X	Assembly, Cable
3	146138	Battery
4	69180	Nut, Lock #10-24 UNC
5	108236X	Bracket, Switch
6	109553X	Switch, Interlock (4 Terminal)
7	146374	Keeper, Actuator
8	17021008	Screw, Hex Head, Tapping #10-24 x 1/2
9	140401	Key, Molded
10	141226	Cover, Key, Ignition
11	140400	Nut, Ignition
12	144921	Switch, Ignition
15	121305X	Switch, Plunger
17	108824X	Fuse
18	128353	Assembly, Cable
19	146064	Harness, Ignition
20	73350400	Nut, Hex, Jam 1/4-20
21	10090400	Washer, Lock 1/4
22	71110408	Bolt, Hex 1/4-20 x 12 Grade 5
24	131563	Cover, Terminal
25	145673	Solenoid
26	74760412	Bolt, Hex Head 1/4-20 UNC x 3/4
27	19091016	Washer 9/32 x 5/8 x 16 Gauge
28	10040400	Washer, Lock, Hvy. Hel. Spring 1/4
30	73220400	Nut, Hex, Fin 1/4-20
31	4152J	Bulb Light #1156
32	136850	Harness Asm Light w/4152J
33	110712X	Switch, Light, Blk, Blk, Red
36	11150400	Washer, Lock Int. Tooth 1/4
39	141735	Bracket Switch, Clutch
55	17490508	Screw Thdrol 5/16-18 x 1/2
70	140413	Harness, Engine

NOTE: All component dimensions given in U.S. inches
1 inch = 25.4 mm

REPAIR PARTS

TRACTOR -- MODEL NUMBER UM1236E

HOOD

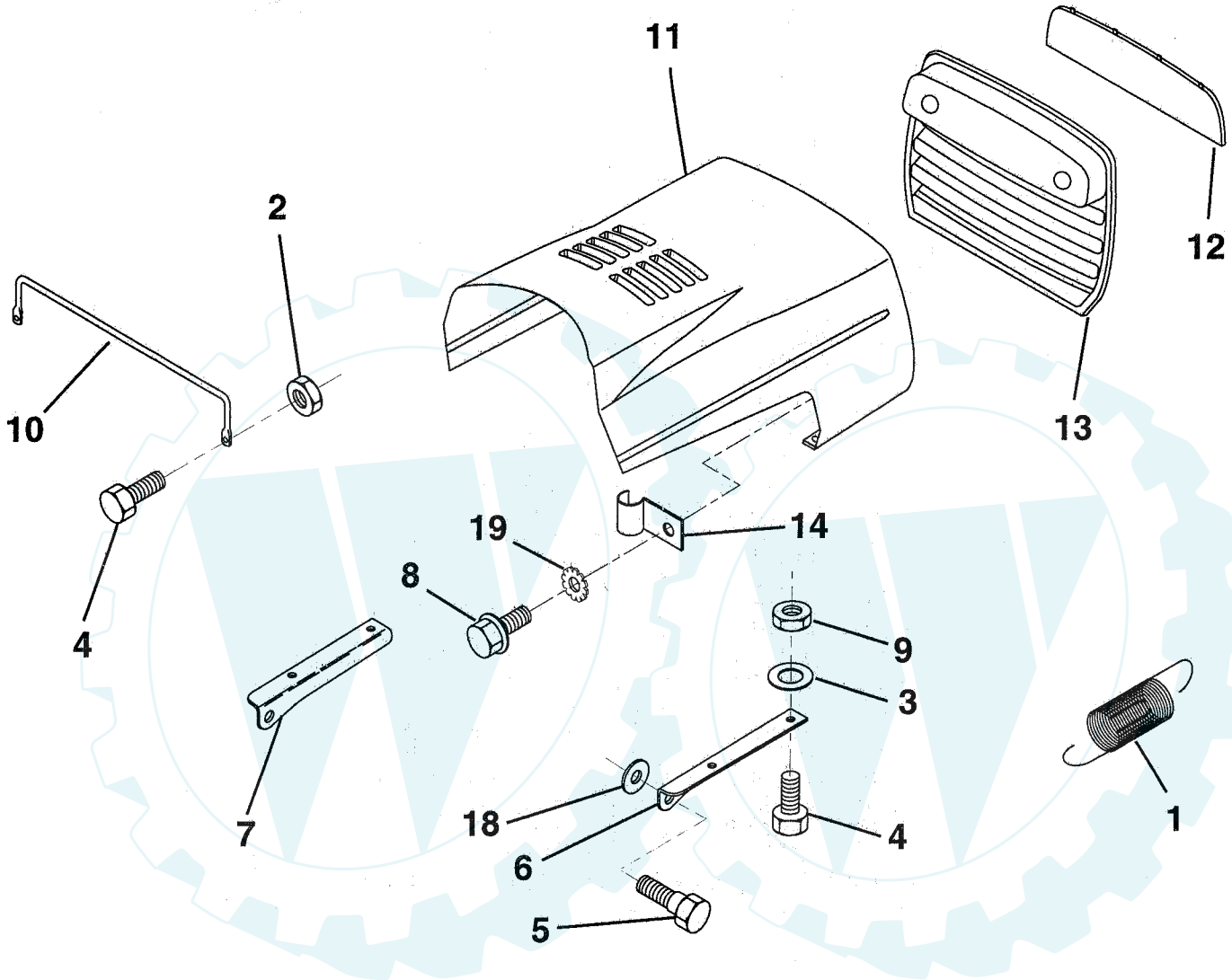

KEY NO.	PART NO.	DESCRIPTION
1	124657X	Spring, Extension
2	73640400	Nut, Hex, Keps 1/4-20 UNC
3	19091416	Washer 9/32 x 7/8 x 16 Gauge
4	74780412	Bolt, Hex, Fin 1/4-20 x .75
5	139888	Bolt, Shoulder
6	122549X	Bracket, Hood, R.H.
7	122548X	Bracket, Hood, L.H.
8	17521310	Screw, Sltd Hex Hd w/Pl Washer
9	73800400	Nut, Lock w/Insert 1/4-20

KEY NO.	PART NO.	DESCRIPTION
10	123693X	Brace, Hood
11	132918X505	Hood
12	122035X	Lens
13	127029X	Grill
14	2751R	Clip Fuel Line 13/32 Mtg Hole
18	19111116	Washer 11/32 x 11/16 x 16 Ga.
19	11030400	Washer, Lock Ext/Int Tooth 1/4

NOTE: All component dimensions given in U.S. inches.
1 inch = 25.4 mm.

HARDWARE SHOWN LARGER FOR EASIER IDENTIFICATION

Der Ersatzteilspezialist im Internet.

REPAIR PARTS

www.ersatzteil-service.de

TRACTOR -- MODEL NUMBER UM1236E

FENDER / CHASSIS

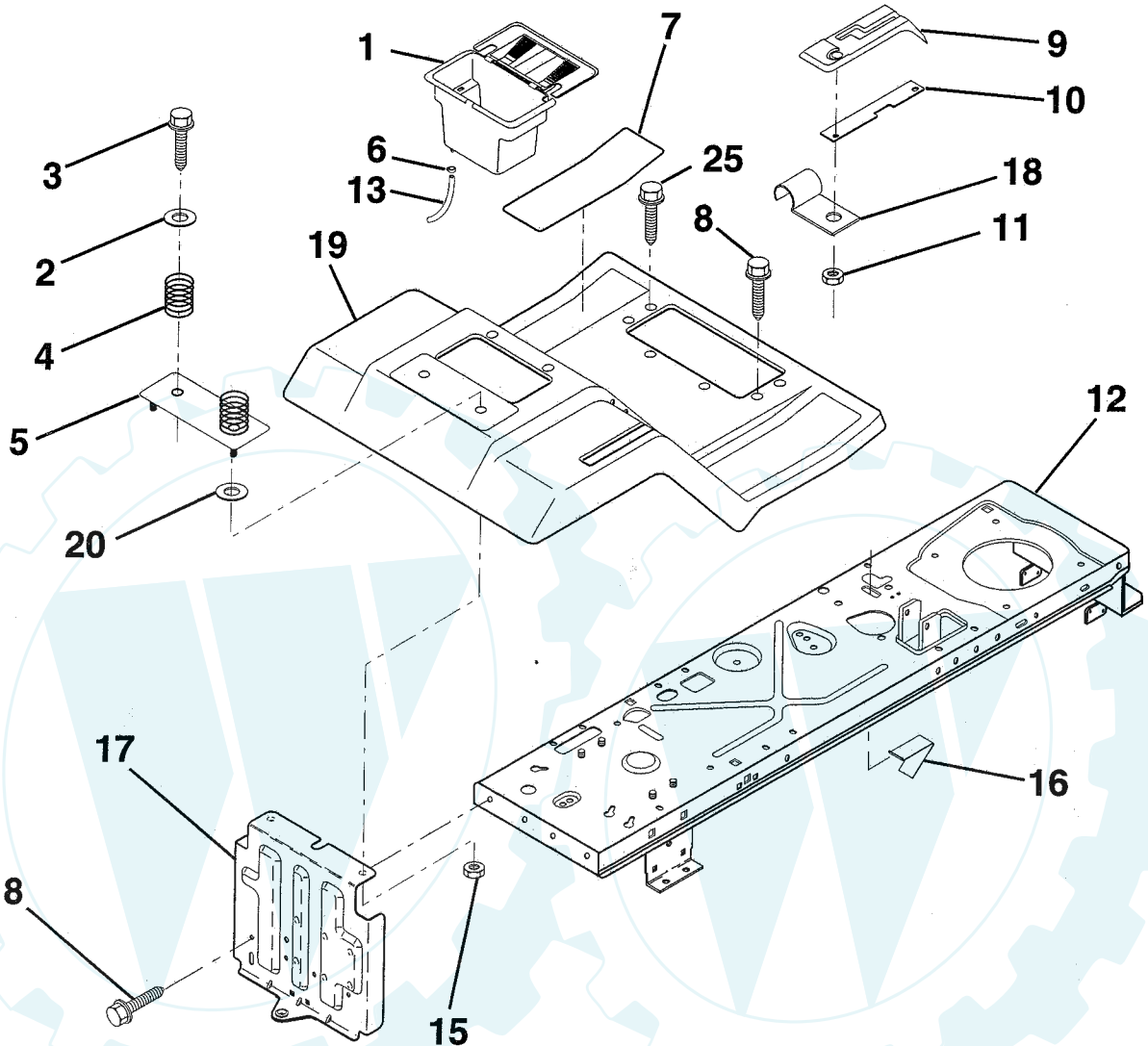

KEY NO.	PART NO.	DESCRIPTION
1	144940	Case, Battery
2	19132012	Washer 13/32 x 1-1/4 x 12 Gauge
3	17490612	Screw, Hex Washer Head, Thd. Roll. 3/8-16 x 3/4
4	124181X	Spring, Compression, Seat
5	127115X505	Plate, Battery
6	109596X	Clamp, Hose
7	124144X	Pad, Footrest
8	17490512	Screw, Hex Washer Head, Thd. Roll. 5/16-18 x 3/4
9	126995X	Console, Shift Control
10	139783	Bar, Shift Lock

KEY NO.	PART NO.	DESCRIPTION
11	124346X	Nut, Self-Threading 3/16
12	145190	Assembly, Frame
13	109238X	Tube, Battery Drain
15	73640400	Nut, Hex, Keps 1/4-20
16	141736	Switch Actuator
17	140782	Drawbar
18	126470X	Clip, Insulated
19	140955X505	Fender/Footrest
20	19091413	Washer 9/32 x 7/8 x 13 Gauge
25	17190516	Scr. - Hx Wsh Thd Rol 5/16-18 x 1T

NOTE: All component dimensions given in U.S. inches.
1 inch = 25.4 mm.

HARDWARE SHOWN LARGER FOR EASIER IDENTIFICATION

Der Ersatzteilspezialist im Internet.

REPAIR PARTS

TRACTOR - - MODEL NUMBER UM1236E

SEAT

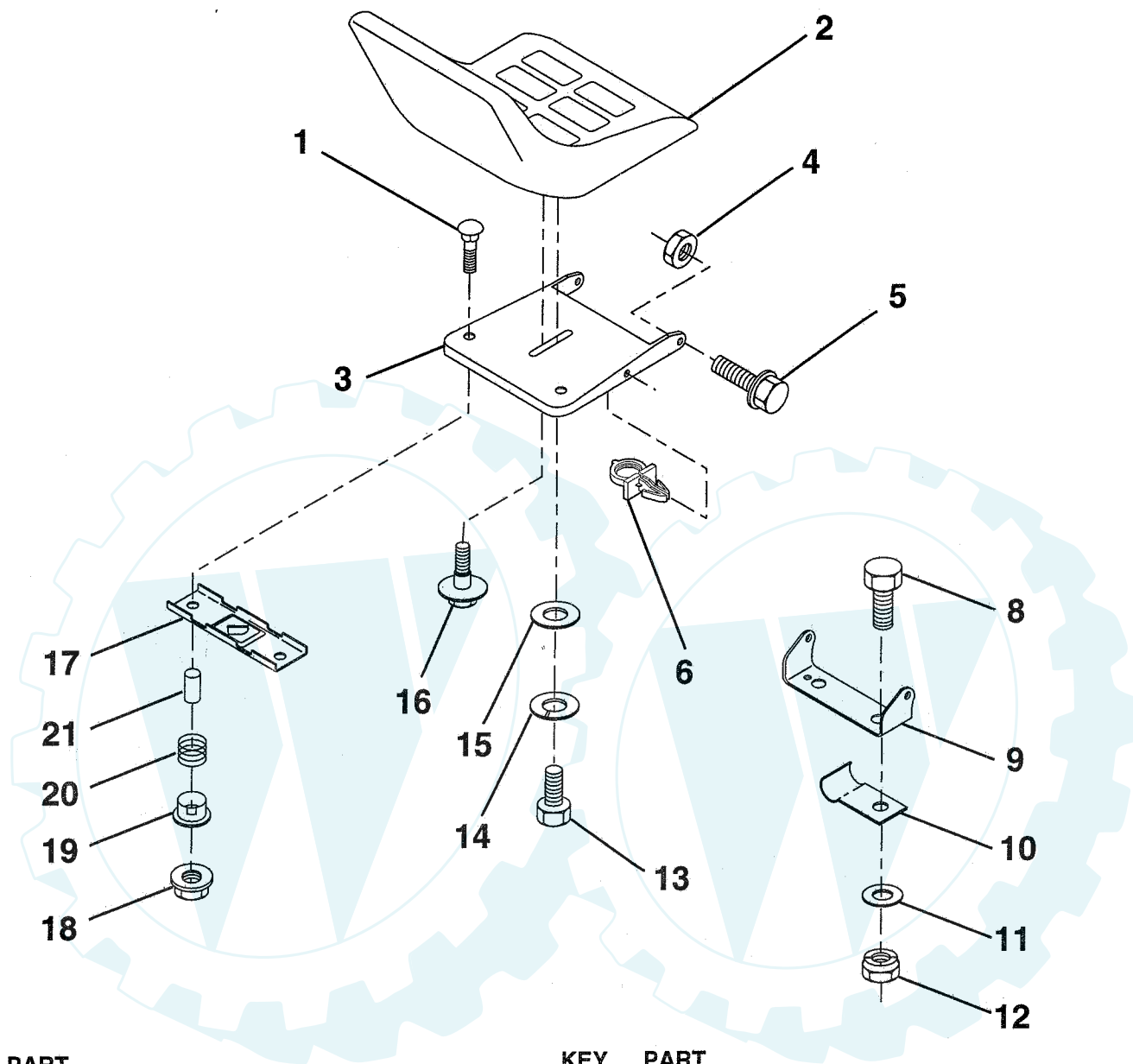

KEY NO.	PART NO.	DESCRIPTION
1	72050411	Bolt, Carriage 1/4-20 x 1-3/8
2	127429X	Seat
3	140552	Pan, Seat
4	73680500	Nut, Crownlock 5/16-18
5	139888	Bolt, Shoulder 5/16-18
6	145006	Clip, Push-In
8	74760616	Bolt, Hex, Fin 3/8-16 UNC x 3/4
9	140551	Bracket, Pivot, Seat
10	126471X	Clip, Insulated
11	19133210	Washer 13/32 x 2 x 10 Gauge
12	73800600	Nut, Lock Hex w/Wsh 3/8-16

KEY NO.	PART NO.	DESCRIPTION
13	74780814	Bolt, Fin Hex 1/2 - 13 x 7/8 Gr. 5
14	10040800	Washer Lock Hvy HLCL Spr. 1/2
15	19171912	Washer 17/32 x 13/16 x 12 Gauge
16	127018X	Bolt, Shoulder
17	121246X	Bracket, Switch, Mounting
18	123976X	Locknut, Hex, Large, Flange
19	121248X	Bushing, Snap
20	123740X	Spring, Compression
21	121249X	Spacer, Split, Large .28 Id. x .88

NOTE: All component dimensions given in U.S. inches.
1 inch = 25.4 mm.

HARDWARE SHOWN LARGER FOR EASIER IDENTIFICATION

Der Ersatzteil-spezialist im Internet.

REPAIR PARTS

www.ersatzteil-service.de

TRACTOR -- MODEL NUMBER UM1236E

DASH

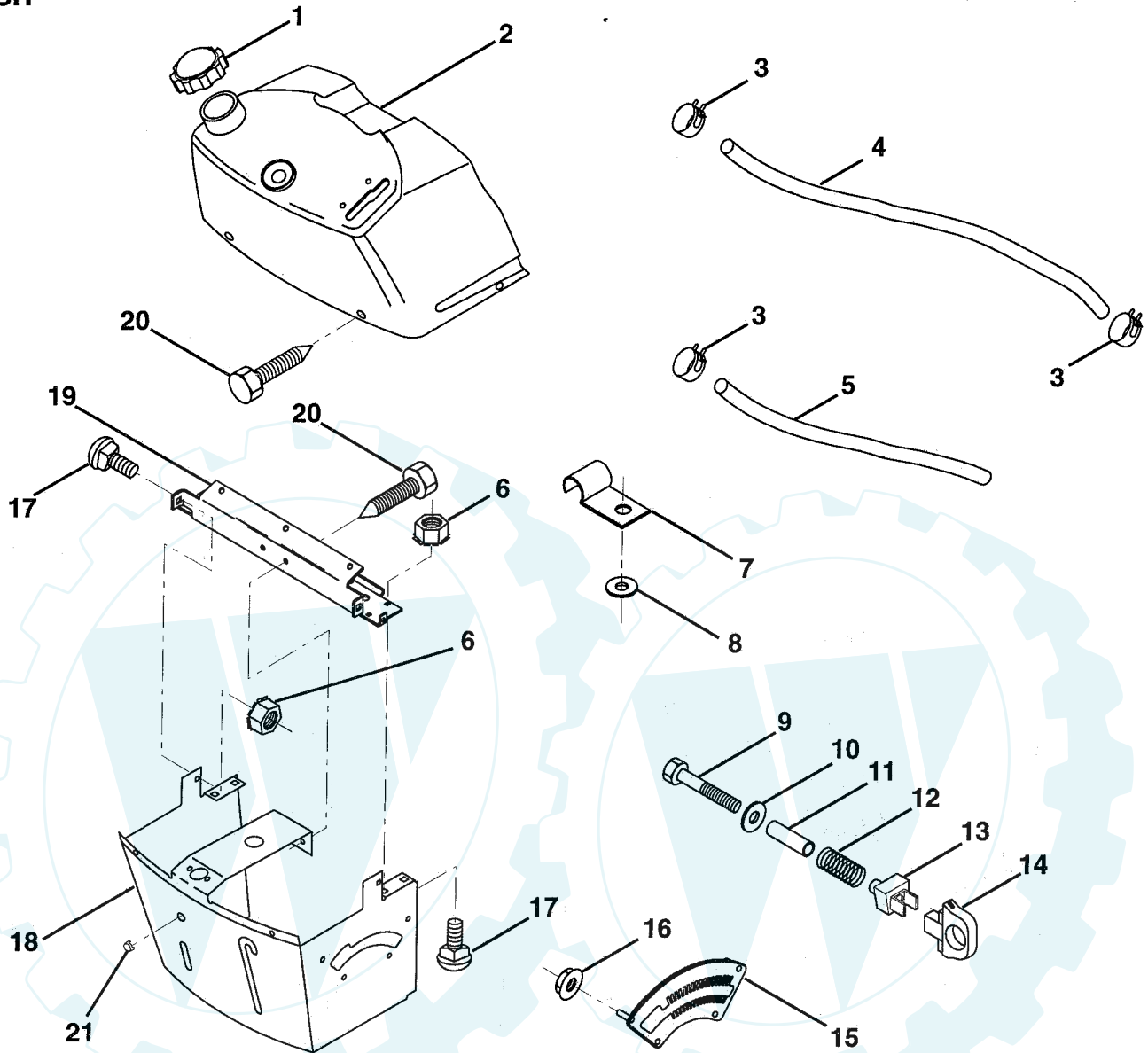

KEY NO.	PART NO.	DESCRIPTION
1	141523	Cap, Fuel
2	138392	Assembly, Dash & Fuel Tank
3	123487X	Clamp, Hose
4	8544R	Line, Fuel
5	8548R	Line, Fuel
6	73640400	Nut, Hex, Keps 1/4-20
7	2751R	Clip, Fuel Line
8	19091216	Washer 9/32 x 3/4 x 16 Gauge
9	74760428	Bolt, Hex, Fin. 1/4-20 x 1-3/4
10	19091413	Washer 11/32 x 11/16 x 16 Gauge
11	121249X	Spacer, Split
12	3720R	Spring

KEY NO.	PART NO.	DESCRIPTION
13	126450X	Clip, Height Adjustment
14	126115X	Knob, Height Stop
15	122023X	Adjustment, Quadrant Height
16	124346X	Nut, Self-Threading 3/16-18
17	72110404	Bolt, Carriage 1/4-20 x 1/2 Grade 5
18	130745	Support Assembly, Dash
19	134744	Brace, Cross
20	17060408	Screw, Tap 1/4-20 x 1/2
21	134014	Plug, Dome

NOTE: All component dimensions given in U.S. inches.
1 inch = 25.4 mm.

HARDWARE SHOWN LARGER FOR EASIER IDENTIFICATION

REPAIR PARTS

www.ersatzteil-service.de

TRACTOR -- MODEL NUMBER UM1236E

STEERING WHEEL

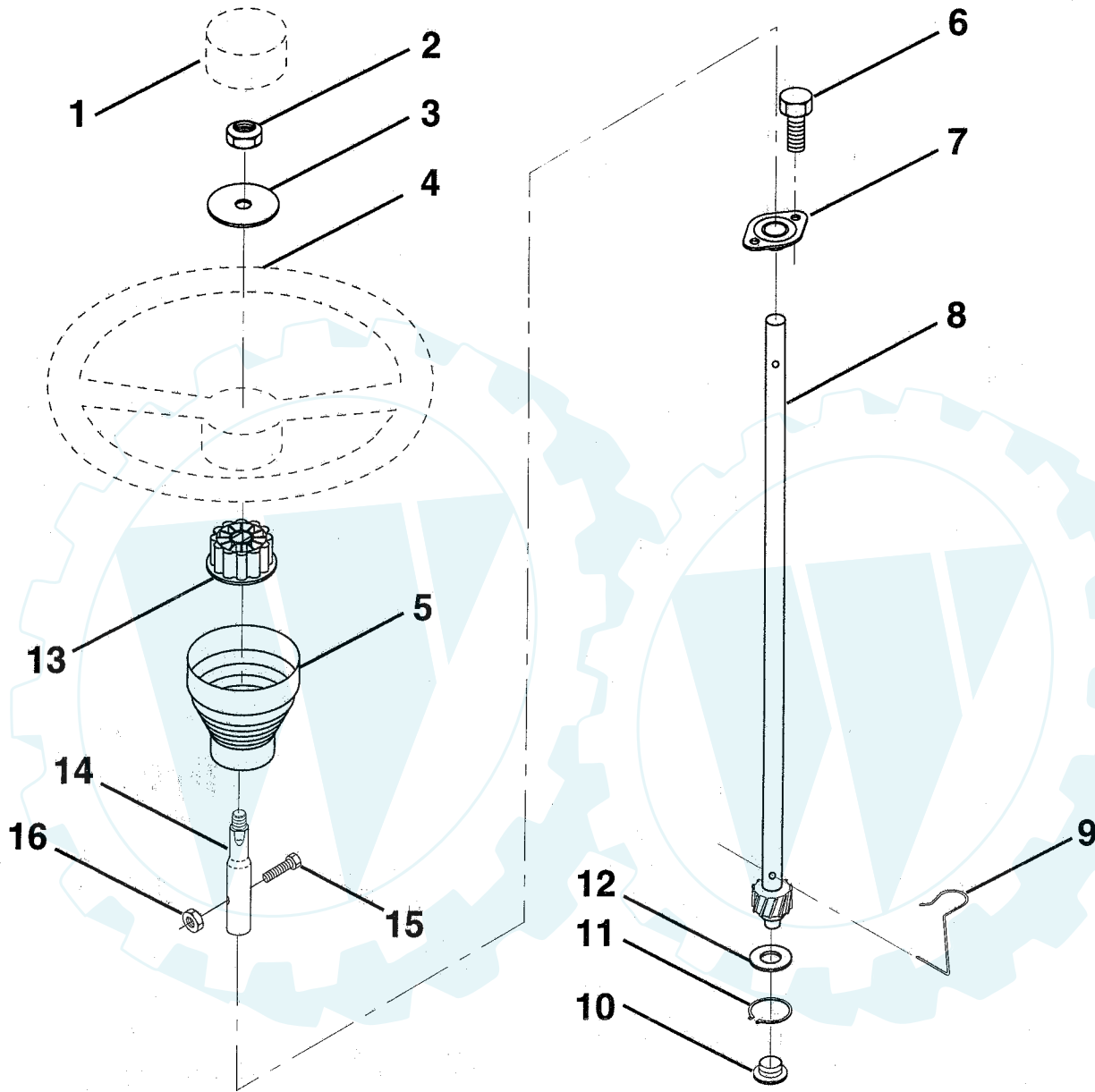

KEY NO.	PART NO.	DESCRIPTION
1	133742	Insert, Steering Wheel
2	7810H	Locknut 3/8-24 UNF
3	19133808	Washer 13/32 x 2-3/8 x 8 Ga.
4	133741	Wheel, Steering
5	121897X	Sleeve, Steering
6	17431008	Screw, Hex Self-Tapping #10-16 x 1/2
7	102803X	Bushing, Steering
8	147391	Shaft, Steering

KEY NO.	PART NO.	DESCRIPTION
9	124210X	Clip, Steering
10	123438X	Bushing, Lower, Steering
11	12000045	Ring, Retaining
12	19211616	Washer 21/32 x 1 x 16 Ga.
13	104820X	Adaptor, Steering Wheel
14	147392	Extension Shaft Steering
15	74780520	Bolt Fin Hex 5/16-18 UNC x 1-1/4
16	73800500	Nut Lock Hex W/Ins 5/16-18 UNC

NOTE: All component dimensions given in U.S. inches.
1 inch = 25.4 mm.

HARDWARE SHOWN LARGER FOR EASIER IDENTIFICATION

REPAIR PARTS

www.ersatzteil-service.de

TRACTOR - - MODEL NUMBER UM1236E

SECTOR GEAR / AXLE SUPPORT

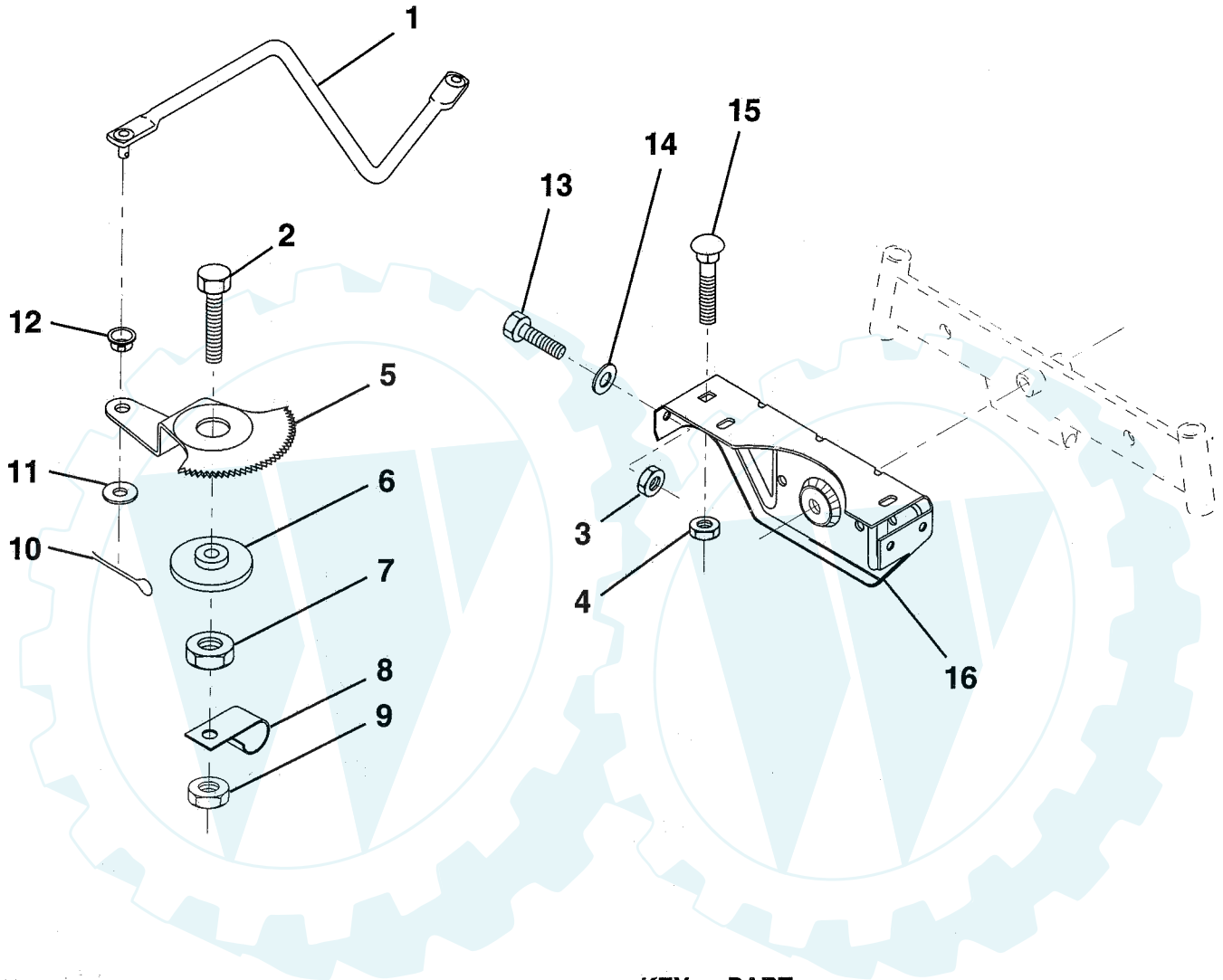

KEY NO.	PART NO.	DESCRIPTION
1	132566	Link, Drag
2	74780828	Bolt, Hex, Fin 1/2-13 x 1-3/4
3	73680500	Nut, Crownlock 5/16-18
4	73680600	Nut, Crownlock 3/8-16
5	121926X	Gear, Sector
6	121927X	Bushing
7	73030800	Nut, Heavy, Hex, Toplock 1/2-13 UNC
8	126472X	Clip, Wire
9	73680800	Nut, Crownlock 1/2-13

KEY NO.	PART NO.	DESCRIPTION
10	76020412	Pin, Cotter 1/8 x 3/4
11	19131316	Washer 13/32 x 13/16 x 16 Ga.
12	126847X	Bushing
13	74760512	Bolt, Hex 5/16-18 x 3/4
14	19111416	Washer 11/32 x 7/8 x 16 Ga.
15	72110606	Bolt, Carriage 3/8-16 UNC x 3/4
16	137096	Support, Front Axle

NOTE: All component dimensions given in U.S. inches.
1 inch = 25.4 mm.

HARDWARE SHOWN LARGER FOR EASIER IDENTIFICATION

TRACTOR - - MODEL NUMBER UM1236E

FRONT AXLE

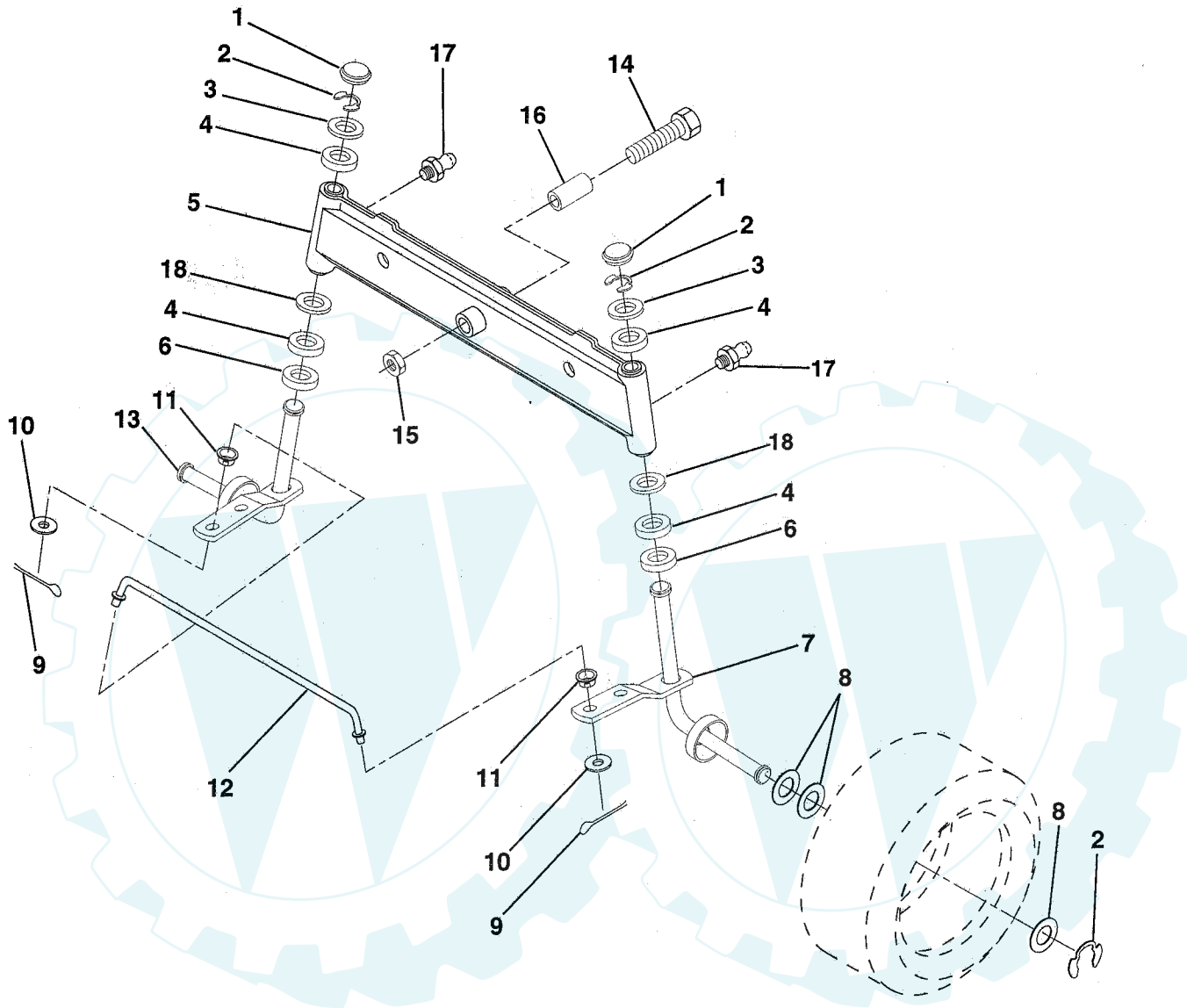

KEY NO.	PART NO.	DESCRIPTION
1	121232X	Cap, Spindle
2	12000029	Ring, Klip
3	121748X	Washer 25/32 x 1-5/8 x 16 Gauge
4	3366R	Bearing
5	142033	Axle, Front
6	6266H	Bearing, Thrust
7	137062	Spindle Assembly, R.H.
8	121749X	Washer 25/32 x 1-1/4 x 16 Gauge
9	76020412	Pin, Cotter 1/8 x 3/4
10	19131316	Washer 13/32 x 13/16 x 16 Gauge
11	126847X	Bushing

KEY NO.	PART NO.	DESCRIPTION
12	130465	Rod, Tie
13	137061	Spindle Assembly, L.H.
14	74011056	Bolt, Hex 5/8-11 x 3-1/2
15	73901000	Nut, Lock Flange 5/8-11
16	110438X	Spacer, Bearing Axle
17	6855M	Fitting, Grease
18	19272016	Washer 27/32 x 1-1/4 x 16 Ga.

NOTE: All component dimensions given in U.S. inches.
1 inch = 25.4 mm.

HARDWARE SHOWN LARGER FOR EASIER IDENTIFICATION

REPAIR PARTS

www.ersatzteil-service.de

TRACTOR -- MODEL NUMBER UM1236E

ENGINE / THROTTLE

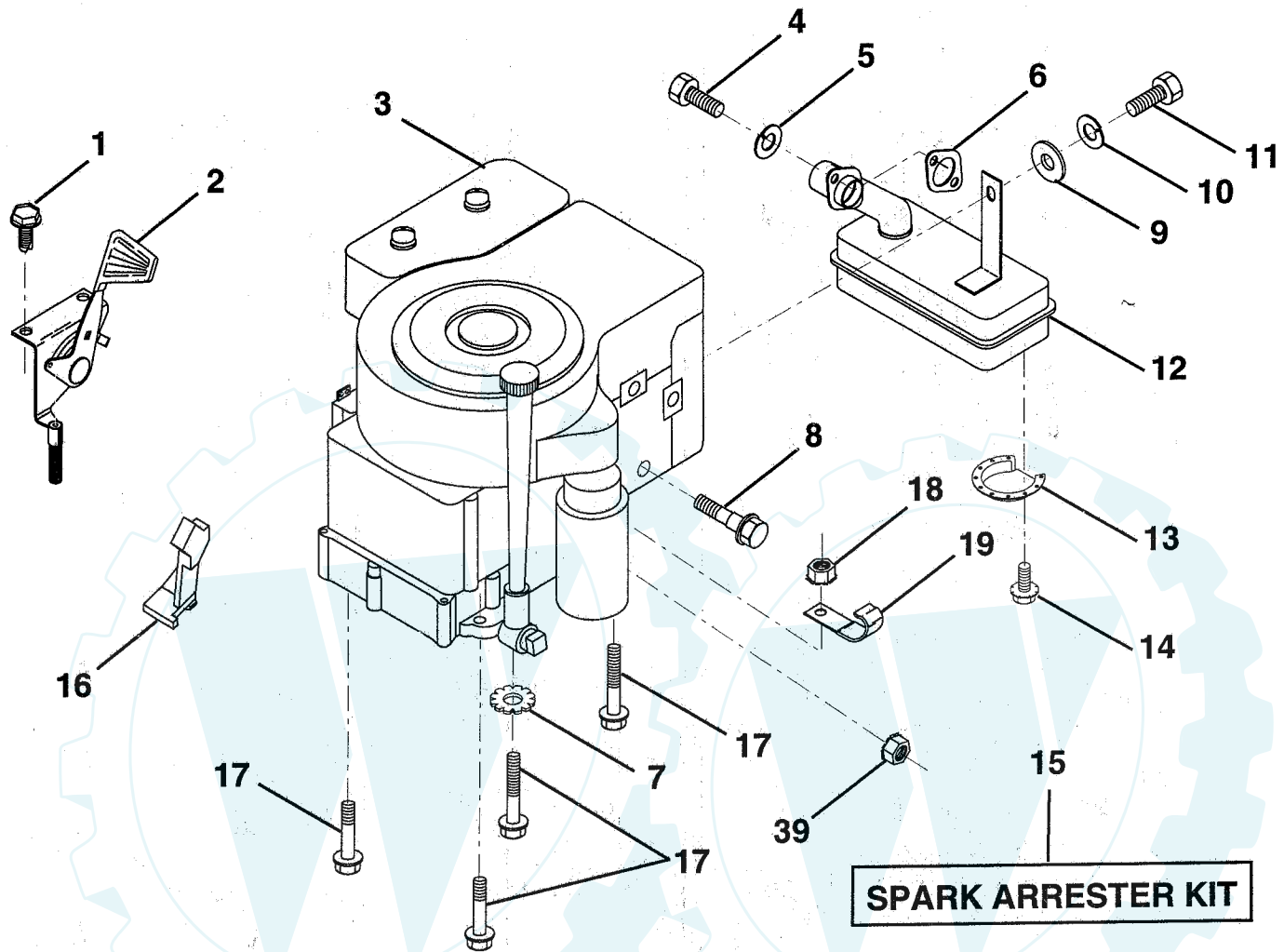

KEY NO.	PART NO.	DESCRIPTION
1	17060408	Screw, Hex, Thread Cutting 1/4-20 x 1/2
2	133025	Control, Throttle
3	-----	Engine, B&S, 12 HP, Model #289707
4	71070512	Screw, Hex Hd
5	10040500	Washer, Lock Heavy Helical Spring 5/16
6	272293	Gasket, Exhaust
7	11050600	Washer Lock, Ext. tooth 3/8
8	121094X	Bolt, Shoulder 5/16 UNC
9	19101216	Washer 5/16 x 3/4 x 16 Gauge
10	10040400	Washer, Lock Hvy Hcl Spring 1/4

KEY NO.	PART NO.	DESCRIPTION
11	-----	Bolt, Hex, Fin (Order From Engine Mfg.)
12	137437	Muffler
13	101326L	Deflector, Muffler
14	17030808	Screw, Spiderlock Hex Hd 8 x 1/2
15	137180	Kit, Spark Arrester (Optional)
17	17490624	Screw, Hex Washer Head, Thd. Roll. 3/8-16 x 1-1/2
16	127951	Stop, Choke
18	73510600	Nut, Keps Hex 3/8-16 UNC
19	2751R	Clip Line Fuel 13/32 Mtg Hole
39	128861	Nut, Flange 1/4-20

NOTE: All component dimensions given in U.S. inches.
1 inch = 25.4 mm

HARDWARE SHOWN LARGER FOR EASIER IDENTIFICATION

TRACTOR - - MODEL NUMBER UM1236E

GROUND DRIVE

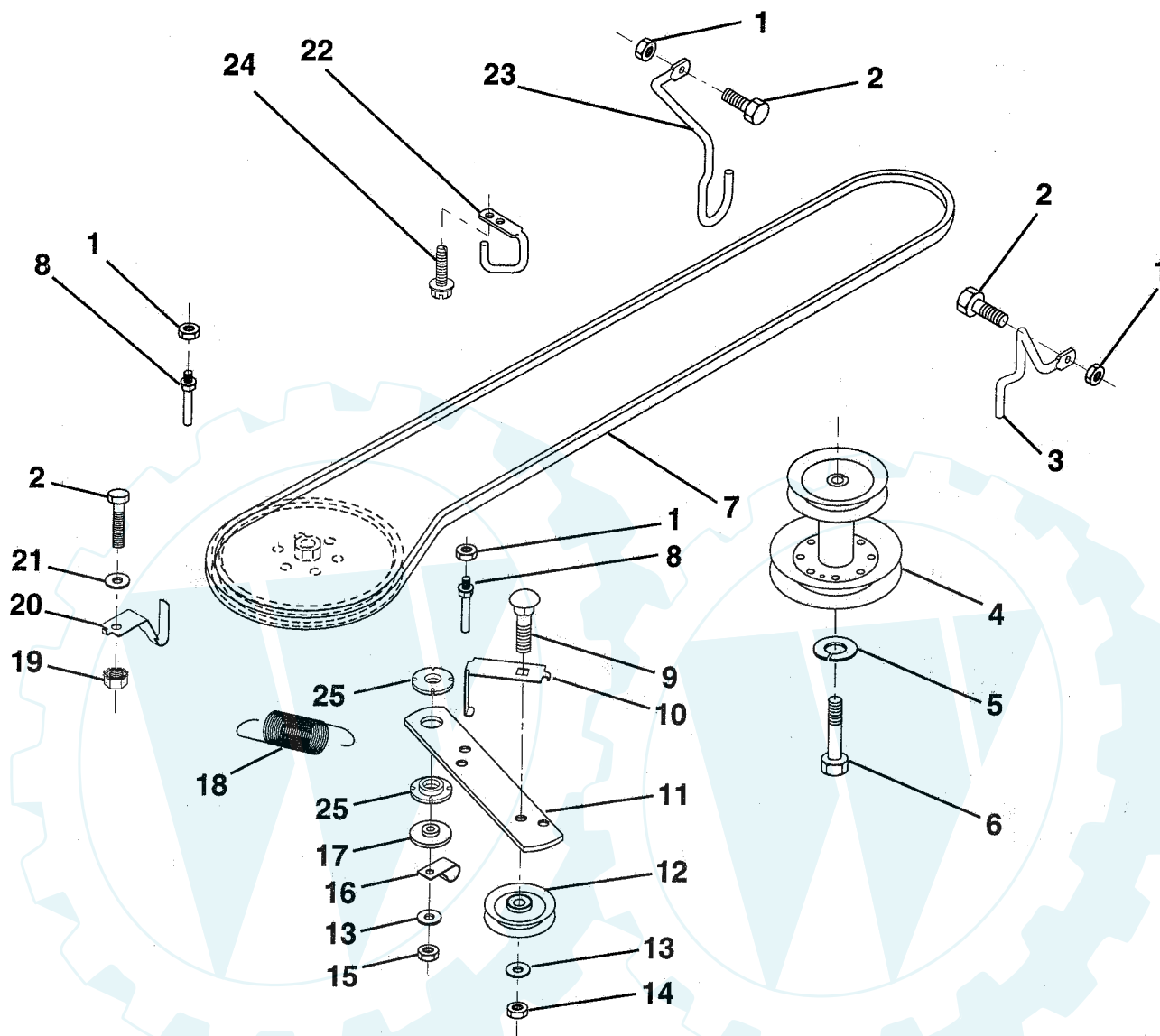

KEY NO.	PART NO.	DESCRIPTION
1	73680500	Nut, Crownlock 5/16-18
2	74760512	Bolt, Hex 5/16-18 UNC x 3/4
3	141342	Keeper, Mower Drive Belt, Engine, R.H.
4	138029	Pulley, Engine
5	10040700	Washer, Lock, Heavy Helical Spring 7/16
6	71170744	Bolt, Hex, 7/16-20 x 2-3/4 Grade 5
7	124525X	Traction, V-Belt Drive
8	123405X	Keeper, T/A Ground Drive Belt
9	72140612	Bolt, Carriage 3/8-16 UNC x 1-1/2
10	123396X	Keeper, Ground Drive Belt, Idler
11	150926	Arm, Ground Drive Clutch
12	123674X	Idler, Flat

KEY NO.	PART NO.	DESCRIPTION
13	19131316	Washer 13/32 x 13/16 x 16 Gauge
14	73930600	Nut, Centerlock 3/8-16 UNC
15	73800600	Nut, Lock Hex w/Wsh 3/8-16
16	126471X	Clip, Insulated
17	150932	Spacer, Retainer
18	131459	Spring, Extension
19	73510500	Nut, Keps 5/16-18 UNC
20	139919	Keeper, T/A Ground Drive Belt
21	19111016	Washer 11/32 x 5/8 x 16 Gauge
22	123404X	Keeper, Ground Drive Belt, Frame
23	140916	Keeper, Belt Eng
24	17720408	Screw, Thd. Cut 1/4-20 x 1/2
25	150935	Bushing, Nylon

NOTE: All component dimensions given in U.S. inches.
1 inch = 25.4 mm

HARDWARE SHOWN LARGER FOR EASIER IDENTIFICATION

REPAIR PARTS

www.ersatzteil-service.de

TRACTOR -- MODEL NUMBER UM1236E

TRANSAXLE

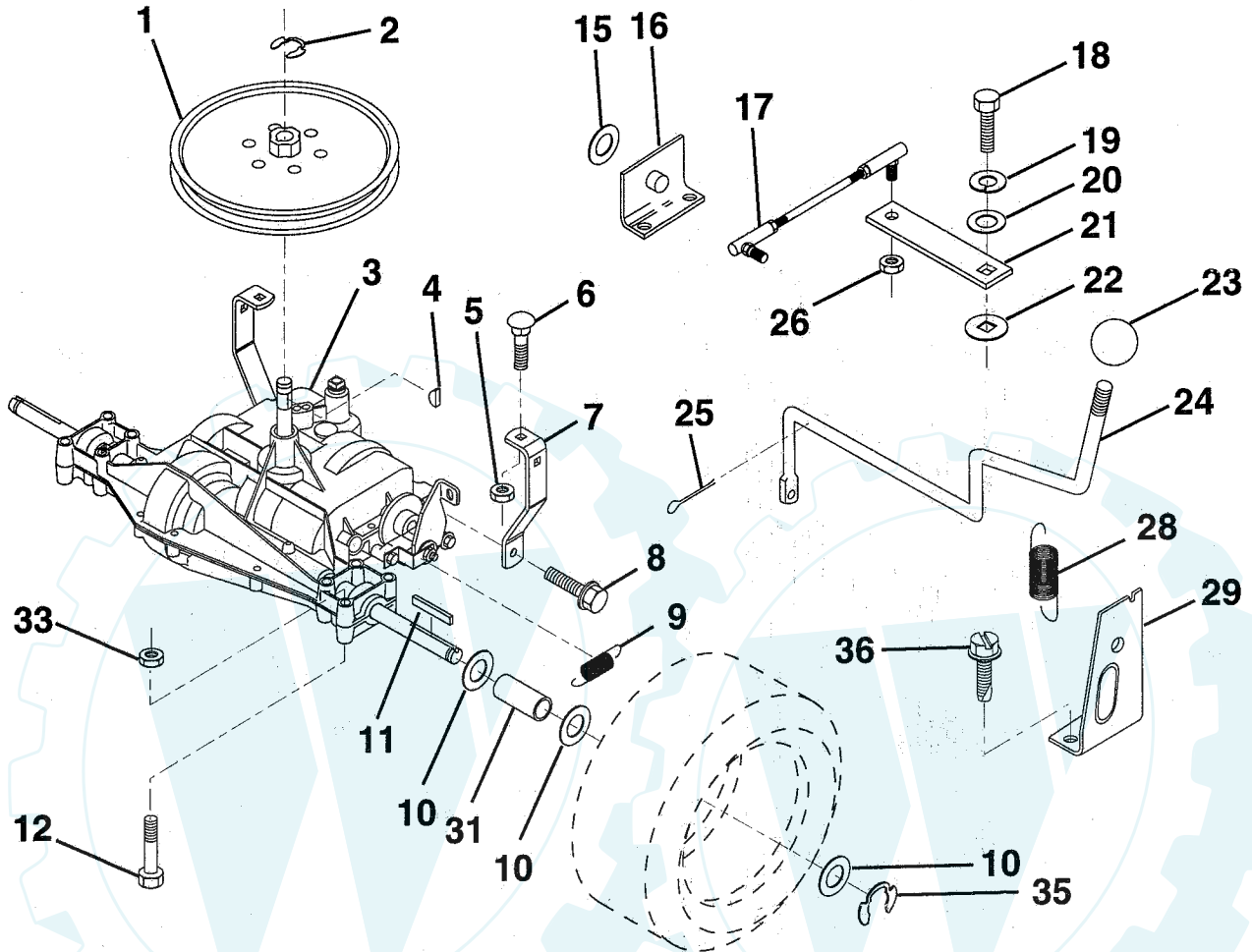

KEY NO.	PART NO.	DESCRIPTION
1	123385X	Pulley
2	1200028	Ring, Retainer
3	142603	Transaxle Model Number 4360-79
4	2228M	Key, Woodruff #9
5	73680500	Nut, Crownlock 5/16-18
6	72140506	Bolt, Carriage 5/16-18 UNC x 3/4
7	123378X	Strap, Torque
8	17490512	Screw 5/16-18 x 3/4
9	146682	Spring, Brake
10	121749X	Washer 25/32 x 1-1/4 x 16 Gauge
11	123583X	Key, Square
12	74760644	Bolt Fin Hex 5/16-18 x 2-1/2
15	19171616	Washer 17/32 x 16 Ga.
16	124600X	Support, Handle Shift LH
17	123632X	Link, Shift
18	74550412	Bolt, Hex, Fin. 1/4-28 UNF x 3/4 Grade 8

KEY NO.	PART NO.	DESCRIPTION
19	10040400	Washer, Lock 1/4
20	19091210	Washer 9/32 x 3/4 x 10 Gauge
21	123539X	Arm, Shift
22	105701X	Washer, Shift Plate
23	106933X	Knob, Rd
24	128215	Rod, Shift
25	76020416	Pin, Cotter 1/8 x 1
26	73810500	Nut, Hex, Nylon 5/16-24 UNF
28	128085	Spring, Extension
29	128084	Support, Handle Shift RH
31	109502X	Spacer, Split
33	73680600	Nut, Crownlock 3/8 - 16
35	12000001	E-Ring
36	17720408	Screw, Thd Cut 1/4-20 x 1/2

NOTE: All component dimensions given in U.S. inches.
1 inch = 25.4 mm.

HARDWARE SHOWN LARGER FOR EASIER IDENTIFICATION

Der Ersatzteilspesialist im Internet.

REPAIR PARTS

www.ersatzteil-service.de

TRACTOR -- MODEL NUMBER UM1236E

BRAKE / REAR MOWER LIFT ASSEMBLY

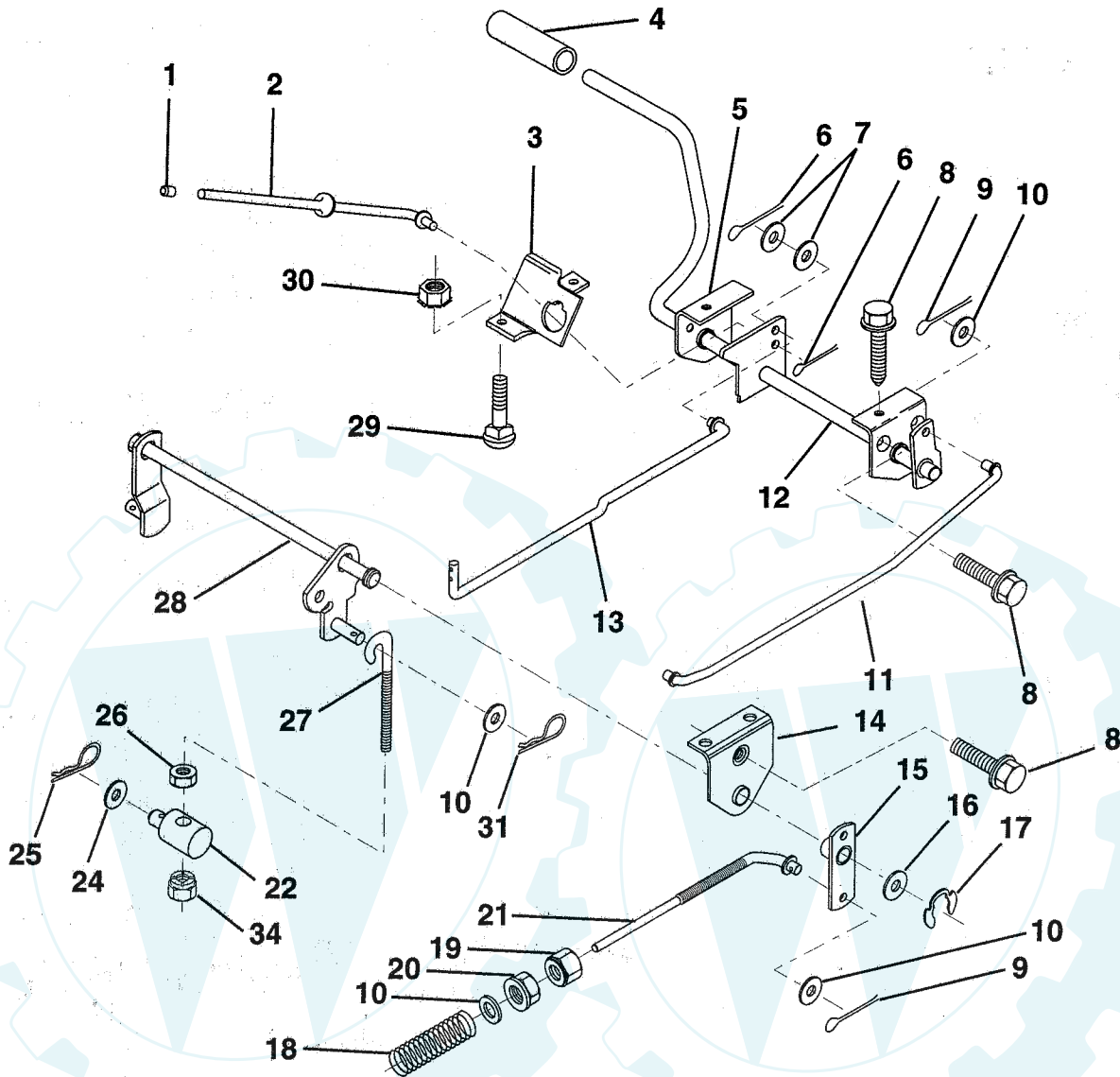

KEY PART
NO. NO.

KEY NO.	PART NO.	DESCRIPTION
1	71673	Cap, Parking Brake
2	123436X	Rod, Parking Brake
3	123437X	Bracket, Parking Brake
4	8156H	Cover, Pedal
5	122504X	Bracket, Pedal, Clutch LH
6	76020312	Pin, Cotter 3/32 x 3/4
7	19131016	Washer 13/32 x 5/8 x 16 Gauge
8	17490508	Screw, Hex, Thd. Roll. 5/16-18 x 1/2
9	76020412	Pin, Cotter 1/8 x 3/4
10	19131316	Washer 13/32 x 13/16 x 16 Gauge
11	123543X	Rod, Front Brake
12	139933	Assembly, Clutch/Brake Pedal
13	123394X	Rod, Clutch
14	121978X	Bracket, Lift, Shaft
15	133332	Assembly, Brake, Pivot, Arm
16	19251816	Washer 25/32 x 1-1/8 x 16 Gauge

KEY PART
NO. NO.

KEY NO.	PART NO.	DESCRIPTION
17	12000034	Ring, Klip
18	151332	Spring, Brake Rod
19	73350600	Nut, Hex, Jam 3/8-16 UNC
20	73800600	Nut, Lock hex w/Wsh 3/8-16
21	131460	Rod, Rear Brake
22	144585	Trunnion, Lift
24	19132012	Washer 13/32 x 1-1/4 x 12 Gauge
25	4921H	Spring, Retainer
26	73930600	Nut, Centerlock 3/8-16 UNC
27	127369	Link, Threaded
28	140776	Assembly, Rear Mower Lift
29	72110506	Bolt, Carriage 5/16-18 UNC x 3/4
30	73510500	Nut, Keps 5/16-18 UNC
31	3141R	Retainer, Spring
34	73680600	Nut, Crownlock 3/8-16

NOTE: All component dimensions given in U.S. inches.
1 inch = 25.4 mm.

HARDWARE SHOWN LARGER FOR EASIER IDENTIFICATION

REPAIR PARTS

TRACTOR -- MODEL NUMBER UM1236E

MOWER LIFT LEVER

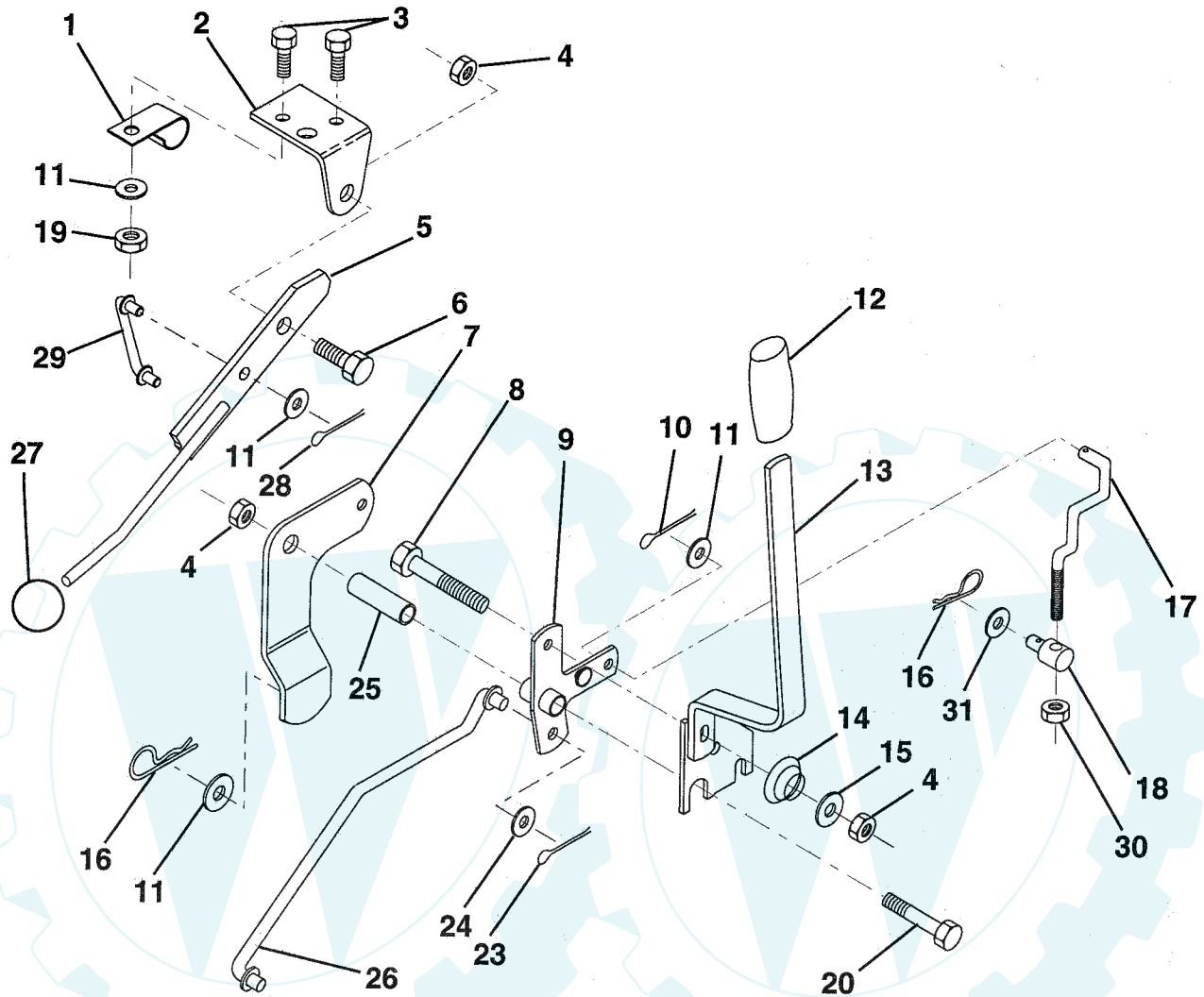

KEY NO.	PART NO.	DESCRIPTION
1	126470X	Clip, Insulated
2	122018X	Bracket, Mower Clutch
3	71110408	Bolt, Hex, Fin 1/4-20 UNC x 1/2 Grade 5
4	73680600	Nut, Crownlock 3/8-16
5	145187	Assembly, Clutch Lever
6	106451X	Bolt, Shoulder
7	135371	Assembly, Mower Clutch Arm
8	74760636	Bolt, Hex 3/8-16 UNC x 2-1/4
9	121930X	Assembly, Bellcrank, Lift
10	76020412	Pin, Cotter 1/8 x 3/4
11	19131316	Washer 13/32 x 13/16 x 16 Gauge
12	131861	Sleeve, Handle
13	139352	Assembly, Lift Handle
14	123496X	Spring, Compression
15	19131212	Washer 13/32 x 3/4 x 12 Gauge

KEY NO.	PART NO.	DESCRIPTION
16	4921H	Retainer, Spring
17	127359	Link, Front Lift
18	142028	Trunnion, Threaded 3/8-16
19	73680400	Nut, Crownlock 1/4-20
20	74760644	Bolt, Hex, Fin. 3/8-16 UNC x 2-3/4
23	76020416	Pin, Cotter 1/8 x 1
24	19171612	Washer 17/32 x 1 x 12 Gauge
25	121933X	Tube, Spacer
26	141470	Rod, Mower Lift
27	106932X	Knob, Rd
28	76020312	Pin, Cotter 3/32 x 3/4
29	131655	Link, Mower Clutch
30	73350600	Nut Hex Jam 3/8-16
31	19132012	Washer 13/32 x 1-1/4 x 12 Gauge

NOTE: All component dimensions given in U.S. inches.
1 inch = 25.4 mm.

REPAIR PARTS

TRACTOR -- MODEL NUMBER UM1236E

MOWER DECK

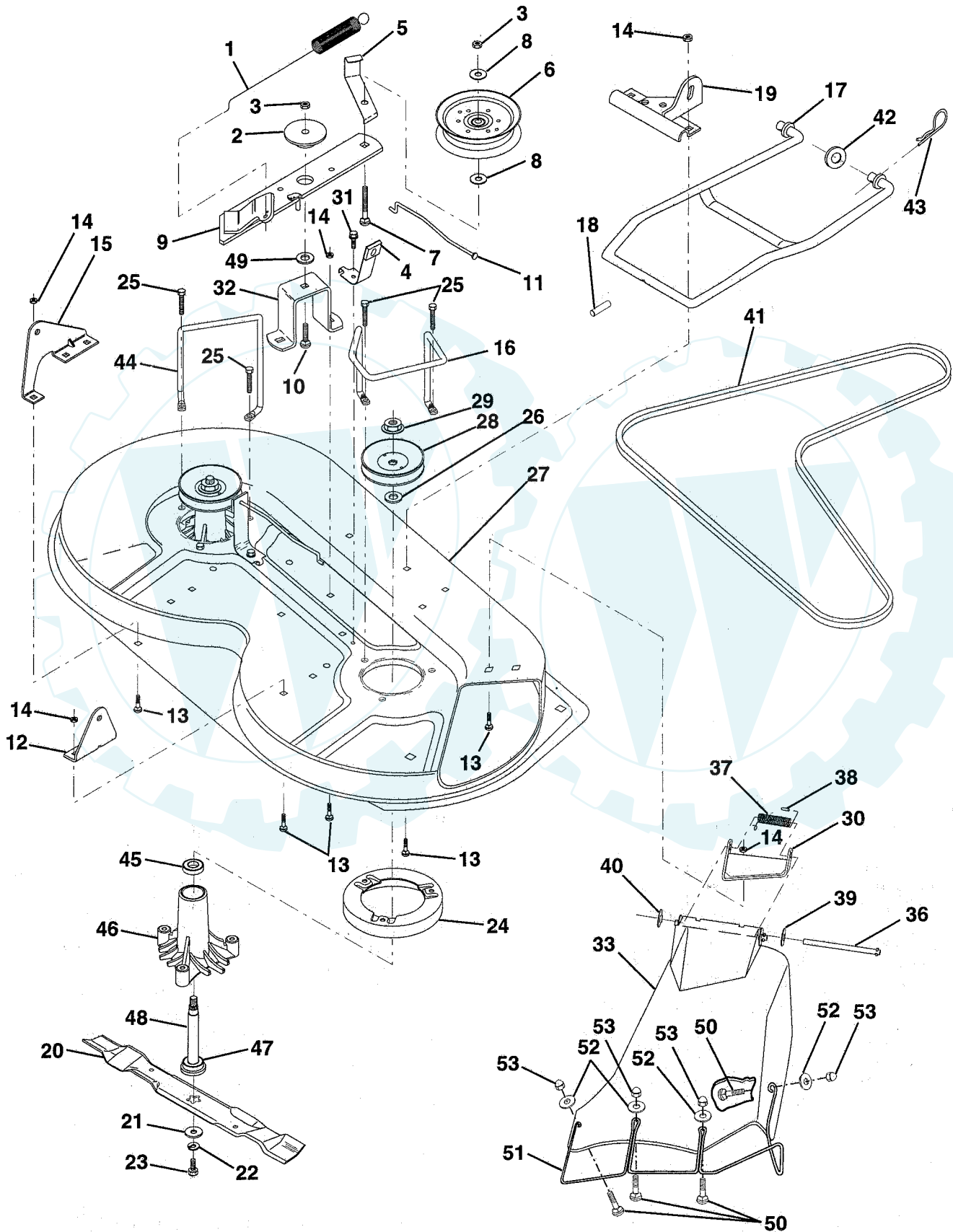

REPAIR PARTS

TRACTOR - - MODEL NUMBER UM1236E

MOWER DECK

KEY NO.	PART NO.	DESCRIPTION	KEY NO.	PART NO.	DESCRIPTION
1	140064	Spring, Mower Clutch	31	17490508	Screw, Hex Washer Head, Thd. Roll. 5/16-18 x 1/2
2	122052X	Spacer, Retainer	32	122051X	Arm, Support Idler, Mower
3	73680600	Nut, Crownlock 3/8-16	33	139083	Shield, Deflector
4	130840	Assembly, Brake	36	121980X	Rod, Hinge
5	131251	Guide, Belt Idler	37	123713X	Spring, Torsion Deflector
6	121316X	Idler, Flat	38	105304X	Cap, Sleeve
7	72110616	Bolt, Carriage 3/8-16 x 2-1/4	39	19111016	Washer 11/32 x 5/8 x 16 Gauge
8	19131410	Washer 13/32 x 7/8 x 10 Gauge	40	110452X	Nut, Push
9	127744	Assembly, Mower Idler Arm	41	131264	V-Belt
10	72140610	Bolt, Carriage 3/8-16 1-1/4	42	19171616	Washer 11/32 x 5/8 x 16 Gauge
11	130841	Rod, Brake	43	3146R	Clip, Hairpin
12	127356	Bracket, Rear Lift, R.H.	44	140608	Keeper, L.H.
13	72140506	Bolt, Carriage 5/16-18 UNC x 5/8	45	110485X	Bearing
14	73680500	Nut, Crownlock 5/16-18	46	128774	Housing, Mandrel, Vented
15	127357	Bracket, Rear Lift, L.H.	47	129895	Bearing
16	140609	Keeper, R.H.	48	137645	Shaft, Mandrel (Includes Key Number 47)
17	128508	Stabilizer, Mower Link	49	133943	Washer, Hardened
18	128511	Pin, Drive	50	71161010	Screw Truss hd Phil 10-24 x 5/8
19	127380	Bracket, Stabilizer Link	51	136383	Guard, Dftr Mwr 36" TUV
20	138496	Blade, High Performance	52	19070718	Washer 7/32 x 7/16 x 18 Gauge
21	140296	Washer, Hard	53	60867	Nut, Acorn Hex #10-24
22	10030600	Washer, Lock, Heavy 3/8	--	130794	Mandrel Assembly (Includes Key Numbers 21-23, 26, 29 and 45-48)
23	850857	Bolt 3/8-24 x 1-1/4 Grade 8	--	144973	Deck, Mower Complete
24	140329	Stripper			
25	138776	Screw, Thdrol Hex Head			
26	129963	Washer .150 Thick			
27	129983	Housing, Mower			
28	129207	Pulley, Mandrel			
29	137266	Nut, Flangelock 9/16			
30	136631	Bracket, Deflector			

NOTE: All component dimensions given in U.S. inches.
1 inch = 25.4 mm.

REPAIR PARTS

TRACTOR -- MODEL NUMBER UM1236E

DECALS

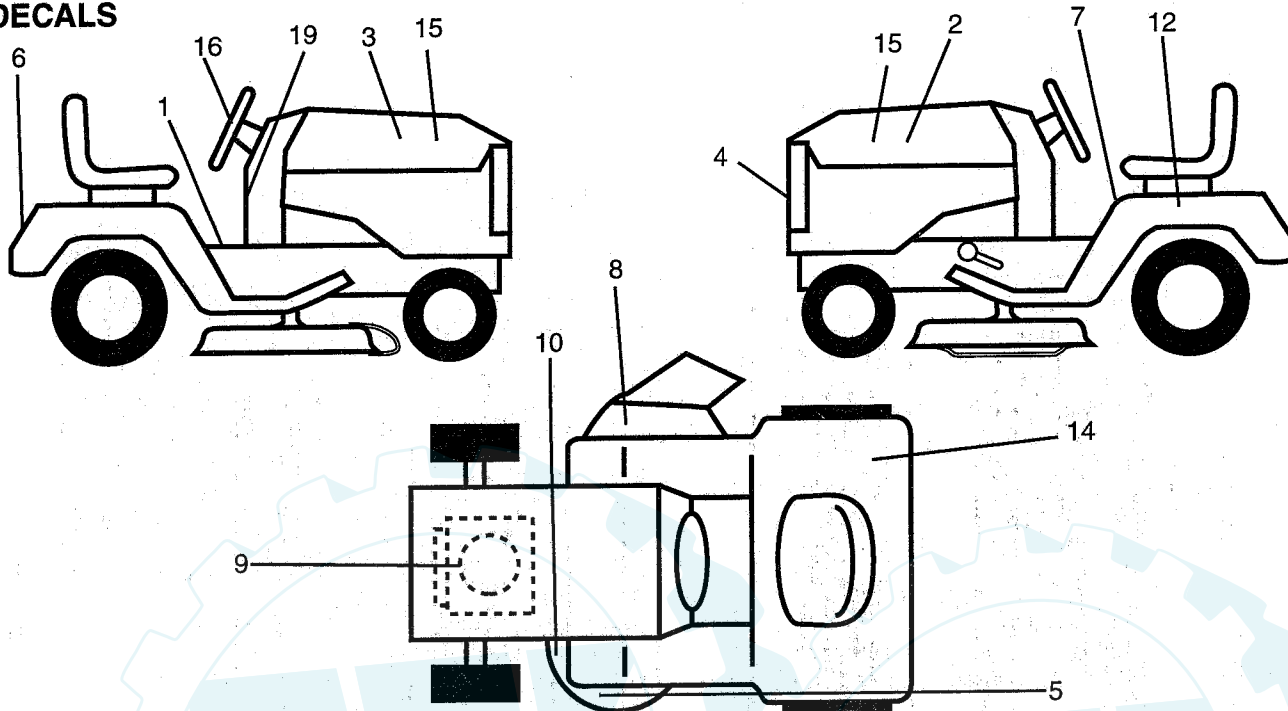

KEY NO.	PART NO.	DESCRIPTION
1	145545	Decal, Inst. Warn. Sym.
2	141744	Decal, Stripe, Hood, L.H.
3	141743	Decal, Stripe, Hood, R.H.
4	132627	Decal, Grill
5	135013	Decal, Enviro
6	132628	Decal, Fender
7	145498	Decal, Red, Owners, Manual, Sym.
8	145494	Decal, Cutfinger, Sym.
9	271967	Decal, Engine HP
10	136830	Decal, V-Belt Schematic

KEY NO.	PART NO.	DESCRIPTION
12	146451	Decal, Caution, Battery
14	125690X	Decal, 100 DbA
15	137460	Decal, Hood Insert 12 HP
16	127075	Decal, Wheel Steering
19	145437	Decal, Europe, Stand Ce
--	138311	Decal, Handle Lift
--	152633	Manual, Operator's (Euro)
--	152597	Manual, Repair Parts
Available accessories are not included with your tractor:		
--	C36	Grass Bagger
--	MK36	Mulcher Kit

TIRES & WHEELS

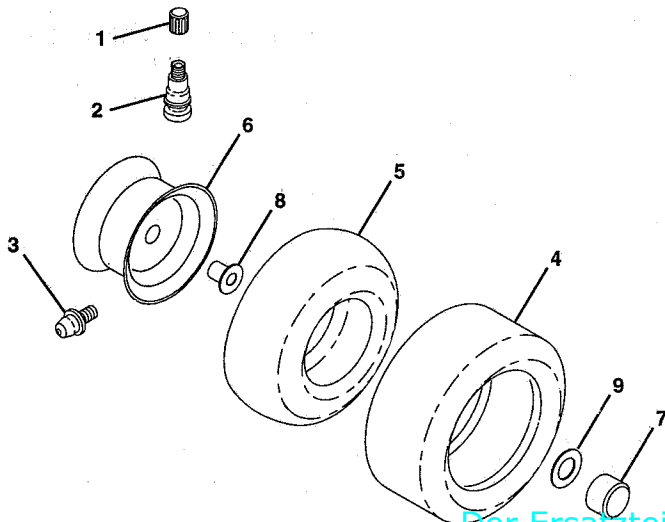

KEY NO.	PART NO.	DESCRIPTION
1	59192	Cap, Valve
2	65139	Stem, Valve
3	278H	Fitting, Grease (Front Only)
4	137422	Tire, Front
	132703	Tire, Rear
5	59904	Tube, Tire, Front
	8134H	(Optional, Service Item Only)
		Tube, Tire, Rear
		(Optional, Service Item Only)
6	137237X473	Rim Assembly, Front
	140325X473	Rim Assembly, Rear
7	104757X	Cap, Axle
8	9040H	Bearing, Flange (Front Only)
9	121748X	Washer, Axle Cap
--	144334	Sealant, Tire (10 oz. Tube)

REPAIR PARTS

TRACTOR - - MODEL NUMBER UM1236E

DANA TRANSAXLE - MODEL NUMBER 4360-79

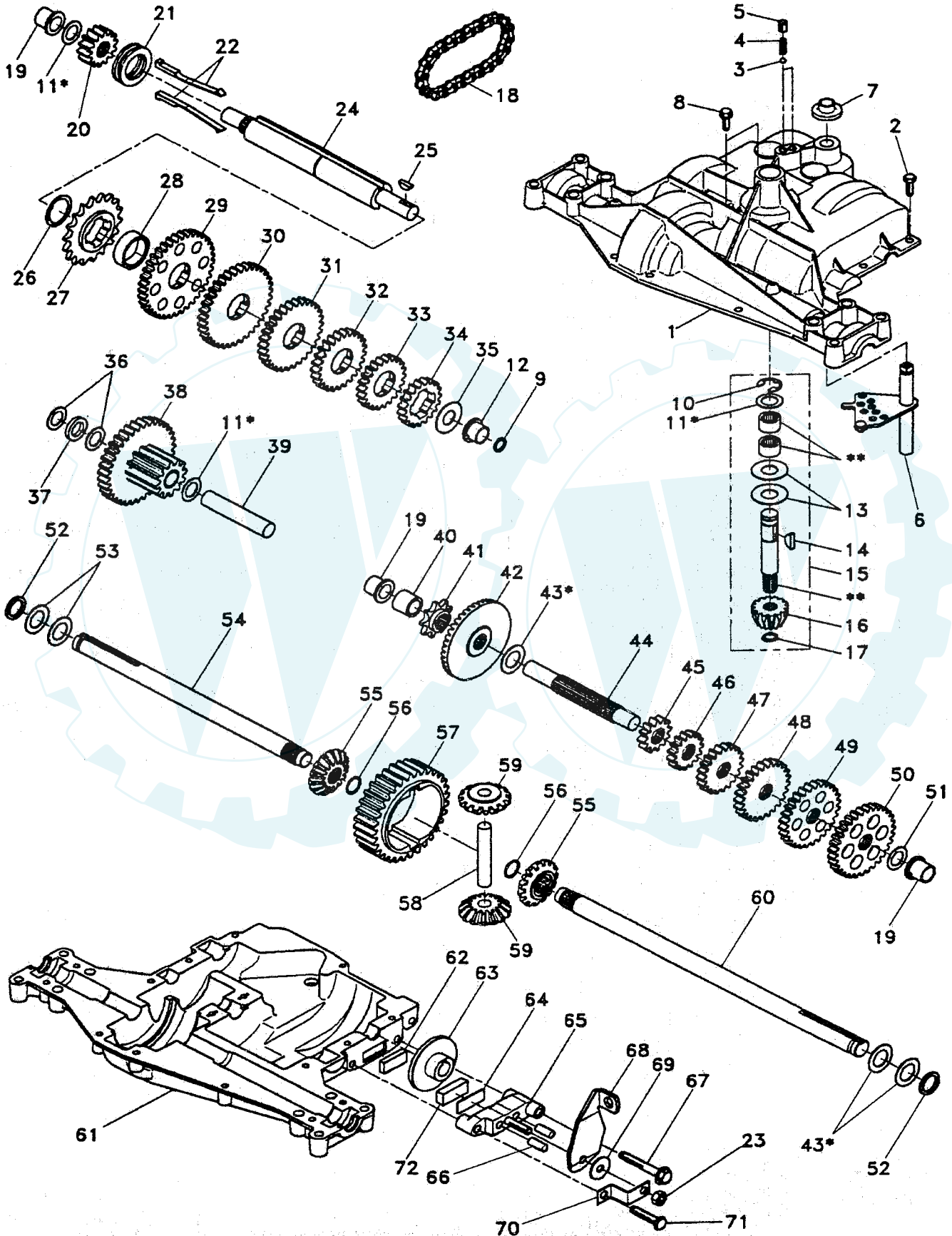

REPAIR PARTS

www.ersatzteil-service.de

TRACTOR - - MODEL NUMBER UM1236E

DANA TRANSAXLE - MODEL NUMBER 4360-79

KEY PART NO.	NO.	DESCRIPTION	KEY PART NO.	NO.	DESCRIPTION
1	142671	Housing, Upper	41	105928X	Sprocket, 9 Teeth
2	2274J	Screw, Self-Tapping, Large 1/4-20 x .734	42	110084X	Gear, Bevel, 42 Teeth
3	134400	Ball, Detent	43	134394	* Assembly, Kit, Shim .750 Shaft
4	105904X	Spring, Detent	44	120473X	Shaft, Drive
5	105905X	Screw, Set	45	142678	Gear, Spur, 12 Teeth
6	138235	Kit, Shifter Assembly	46	142679	Gear, Spur, 15 Teeth
7	134399	Boot, Shifter	47	120407X	Gear, Spur, 20 Teeth
8	134791	Screw, Tapping w/Sealer	48	106589X	Gear, Spur, 25 Teeth
9	138241	Square Ring	49	120408X	Gear, Spur, 28 Teeth
10	142672	Ring, Retaining	50	105937X	Gear, Spur, 31 Teeth
11	134793	* Assembly, Kit, Shim .625 Shaft	51	2226J	Washer, Plain .632 x 1.00 x .060
12	142673	Bearing, Flange	52	134401	Washer, Neoprene
13	120415X	Washer, Plain .632 x 1.38 x .046	53	2264J	Washer, Plain .758 x 1.25 x .031
14	142674	Key, Woodruff, #9	54	120474X	Axle, L.H.
15	138234	Assembly, Kit, Input Shaft	55	110081X	Gear, Miter, 15 Teeth
16	110078X	Pinion, Bevel, 14 Teeth	56	105941X	Ring, Retaining
17	105909X	Ring, Retaining	57	110071X	Gear, Spur, 32 Teeth
18	105910X	Chain, 24 Pitches	58	120952X	Shaft, Cross
19	105911X	Bearing, Flange	59	110082X	Gear, Miter, 15 Teeth
20	142675	Gear, Spur, 14 Teeth	60	120475X	Axle, R.H.
21	138246	Collar, Clutch	61	142680	Housing, Lower
22	138236	Assembly, Kit, Clutch Keys	62	120961X	Puck, Friction
23	73810500	Locknut 5/16-24	63	7294J	Disc, Brake
24	142676	Shaft, Intermediate	64	108989X	Spacer
25	2244J	Key, Woodruff, #61	65	120953X	Jaw, Brake
26	105916X	Ring, Retaining	66	120954X	Pin, Dowel
27	120470X	Sprocket, 18 Teeth	67	134799	Screw, Self-Tapping, Large 5/16-18 x 2.25
28	110070X	Spacer	68	138244	Lever, Actuating
29	142677	Gear, Spur, 37 Teeth	69	108996X	Washer, Plain .321 x 1.00 x .055
30	142681	Gear, Spur, 35 Teeth	70	120956X	Bracket, Anti-Rotation
31	120405X	Gear, Spur, 30 Teeth	71	106596X	Screw, Self-Tapping, Large 5/16-18 x 1.44
32	108980X	Gear, Spur, 25 Teeth	72	120951X	Puck, Friction
33	120406X	Gear, Spur, 22 Teeth	73	120416X	Grease
34	134796	Gear, Spur, 19 Teeth			
35	105925X	Washer, Plain .640 x 1.37 x .061			
36	2232J	Washer, Plain .632 x 1.00 x .026			
37	108978X	Spacer .630 x 1.00 x .169			
38	110079X	Assembly, Gear, Combination of 12 Teeth and 35 Teeth			
39	124639X	Shaft, Idler			
40	120472X	Spacer .635 x .875 x .755			

* Use in combinations to maintain proper clearances

** Order Key No. 15

NOTE: All component dimensions given in U.S. inches
1 inch = 25.4 mm