

TRACTOR- -MODEL NO. RER155H42E

SCHEMATIC

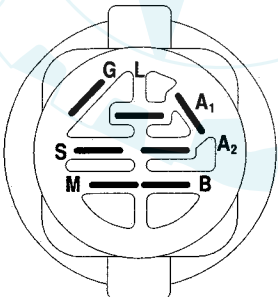
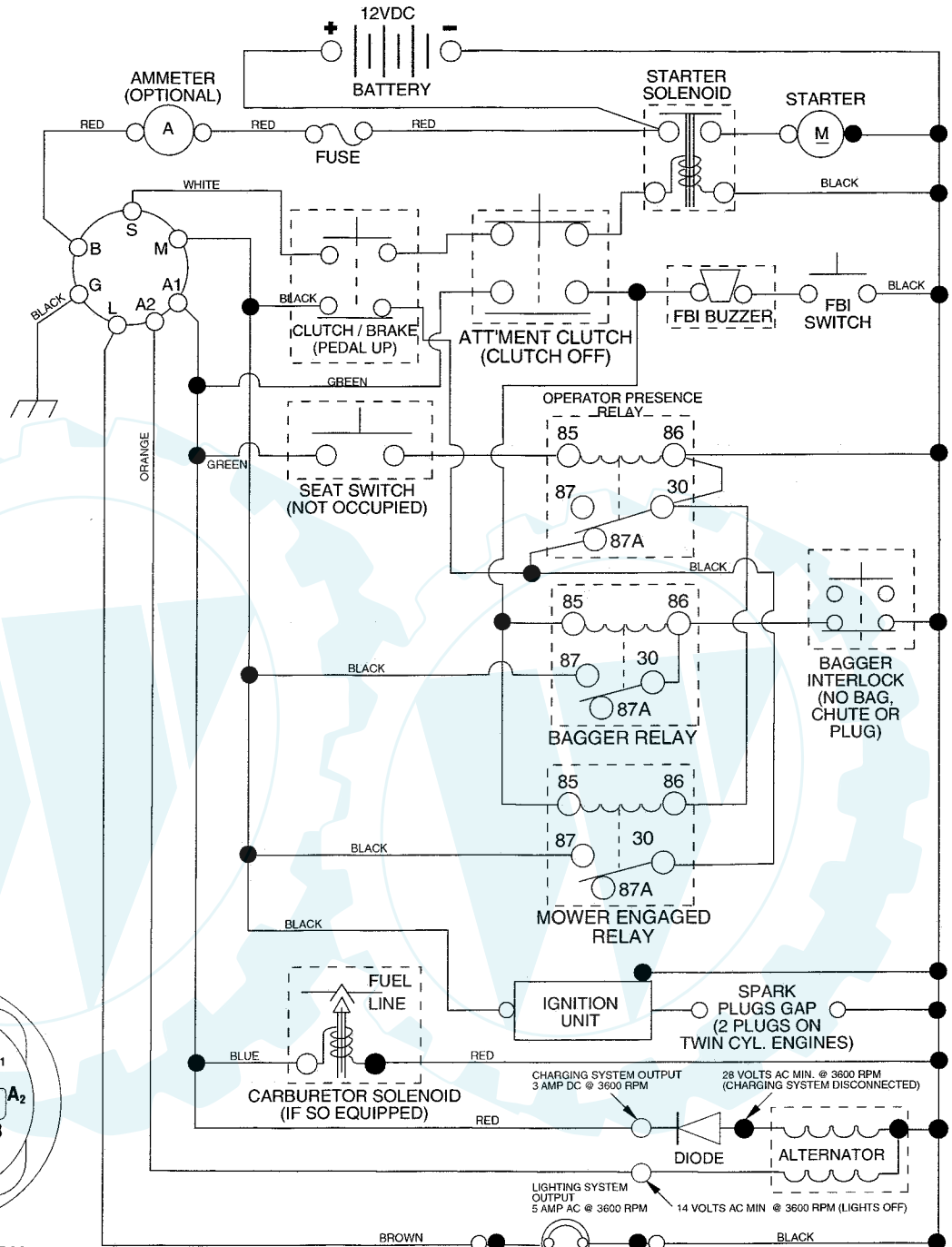

IGNITION SWITCH

POSITION	CIRCUIT	"MAKE"
OFF	M+G+A1	NONE
RUN/LIGHT	B+A1	A2+L
RUN	B+A1	NONE
START	B + S + A1	NONE

WIRING INSULATED CLIPS
NOTE: IF WIRING INSULATED CLIPS WERE REMOVED FOR SERVICING OF UNIT, THEY SHOULD BE REPLACED TO PROPERLY SECURE YOUR WIRING.

●
NON-REMOVABLE CONNECTIONS

○
REMOVABLE CONNECTIONS

PTO SWITCH

POSITION	CIRCUIT
OFF	C + G, B + H
ON	C + F, B + E, A + D

HEADLIGHTS

NOTE
YOUR TRACTOR IS EQUIPPED WITH A SPECIAL ALTERNATOR SYSTEM. THE LIGHTS ARE NOT CONNECTED TO THE BATTERY, BUT HAVE THEIR OWN ELECTRICAL SOURCE. BECAUSE OF THIS, THE BRIGHTNESS OF THE LIGHTS WILL CHANGE WITH ENGINE SPEED. AT IDLE THE LIGHTS WILL DIM. AS THE ENGINE IS SPEEDED UP, THE LIGHTS WILL BECOME THEIR BRIGHTEST.

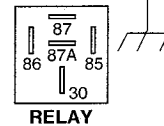

RELAY

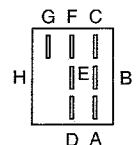

REPAIR PARTS

www.ersatzteil-service.de

TRACTOR- -MODEL NO. RER155H42E

ELECTRICAL

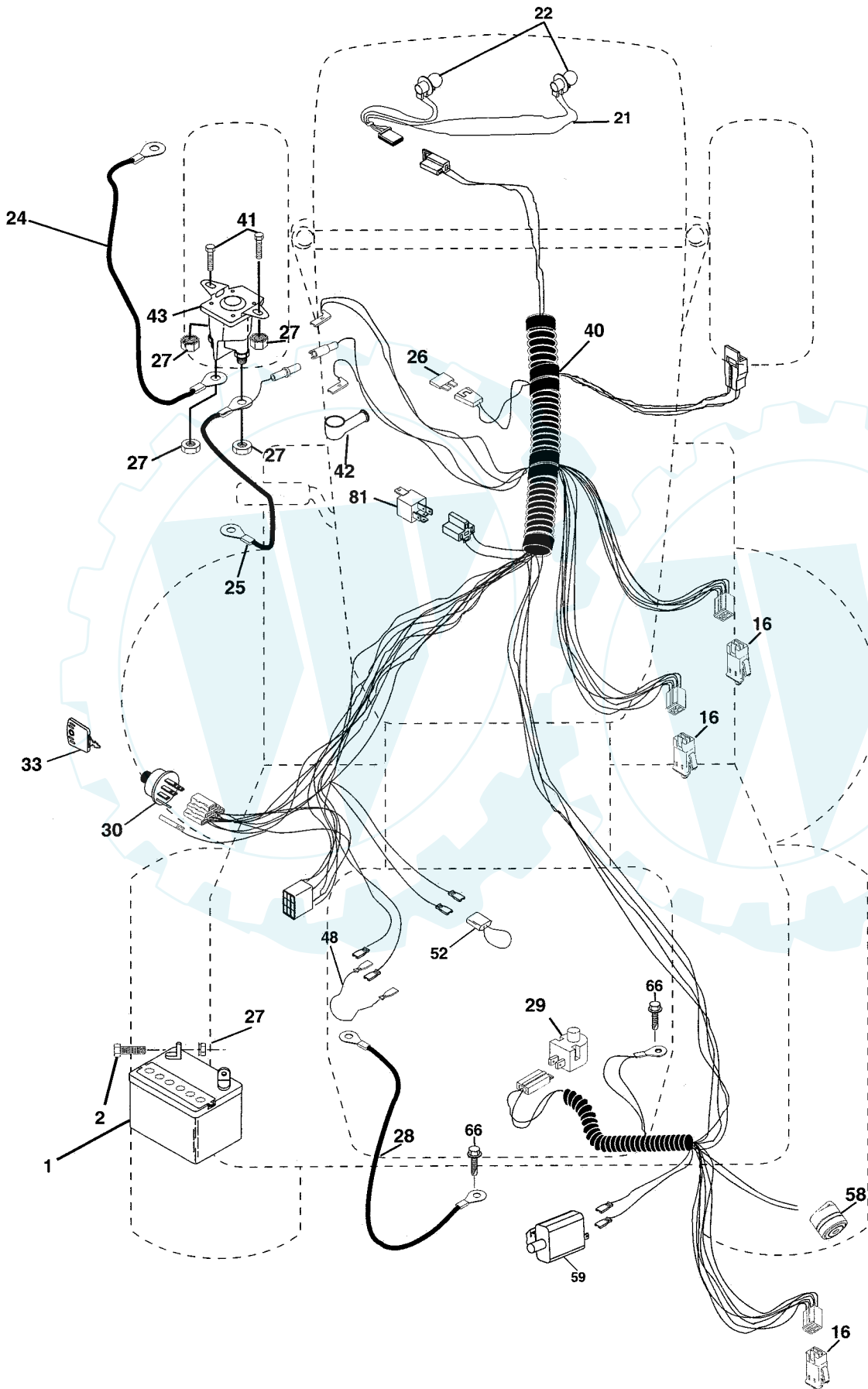

Der Ersatzteilspezialist im Internet.

REPAIR PARTS

www.ersatzteil-service.de

TRACTOR- -MODEL NO. RER155H42E

ELECTRICAL

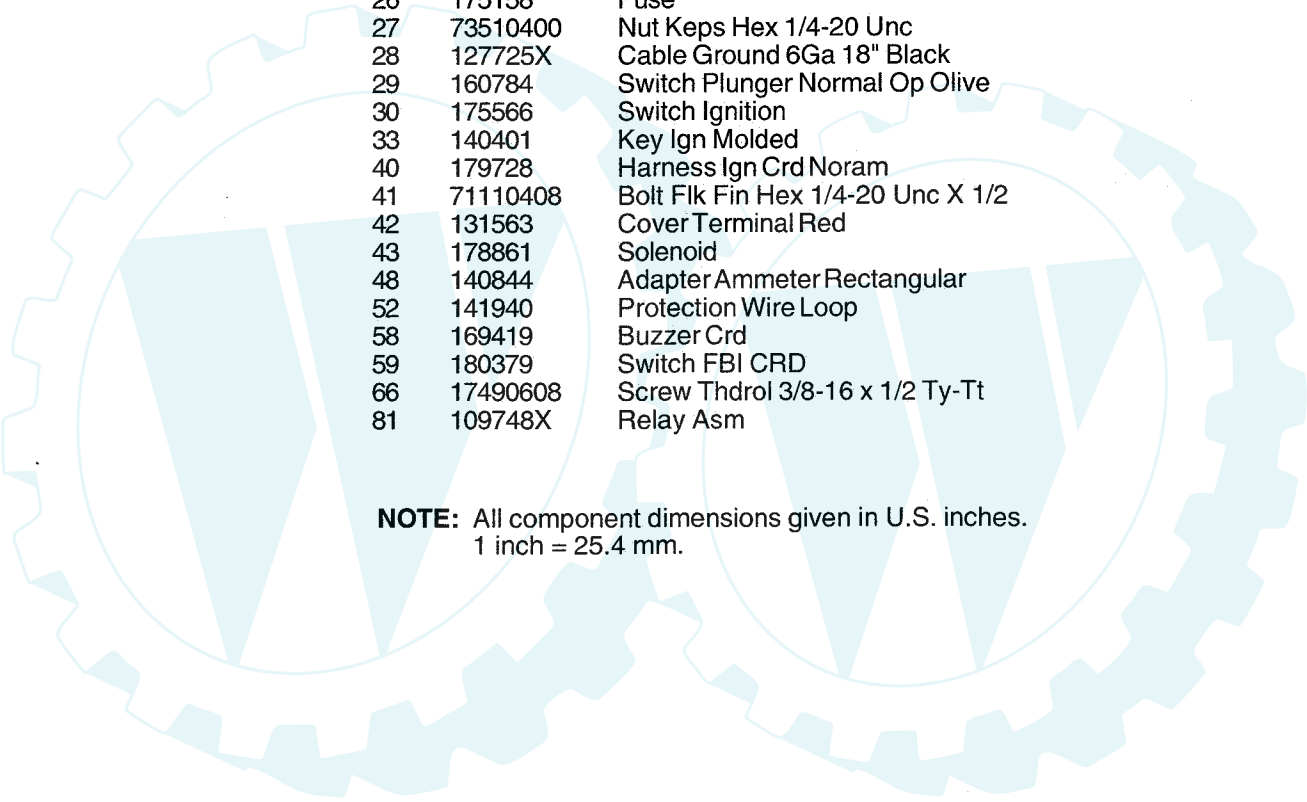

KEY NO.	PART NO.	DESCRIPTION
1	163465	Battery
2	74760412	Bolt Hex Hd 1/4-20 Unc X 3/4
16	176138	Switch Interlock
21	175685	Harness Asm Light W/4152J
22	4152J	Bulb Light #1156
24	4799J	Cable Battery
25	165987	Cable Battery Crd 56" Red
26	175158	Fuse
27	73510400	Nut Keps Hex 1/4-20 Unc
28	127725X	Cable Ground 6Ga 18" Black
29	160784	Switch Plunger Normal Op Olive
30	175566	Switch Ignition
33	140401	Key Ign Molded
40	179728	Harness Ign Crd Noram
41	71110408	Bolt Flk Fin Hex 1/4-20 Unc X 1/2
42	131563	Cover Terminal Red
43	178861	Solenoid
48	140844	Adapter Ammeter Rectangular
52	141940	Protection Wire Loop
58	169419	Buzzer Crd
59	180379	Switch FBI CRD
66	17490608	Screw Thdrol 3/8-16 x 1/2 Ty-Tt
81	109748X	Relay Asm

NOTE: All component dimensions given in U.S. inches.
1 inch = 25.4 mm.

REPAIR PARTS

www.ersatzteil-service.de

TRACTOR- -MODEL NO. RER155H42E

CHASSIS AND ENCLOSURES

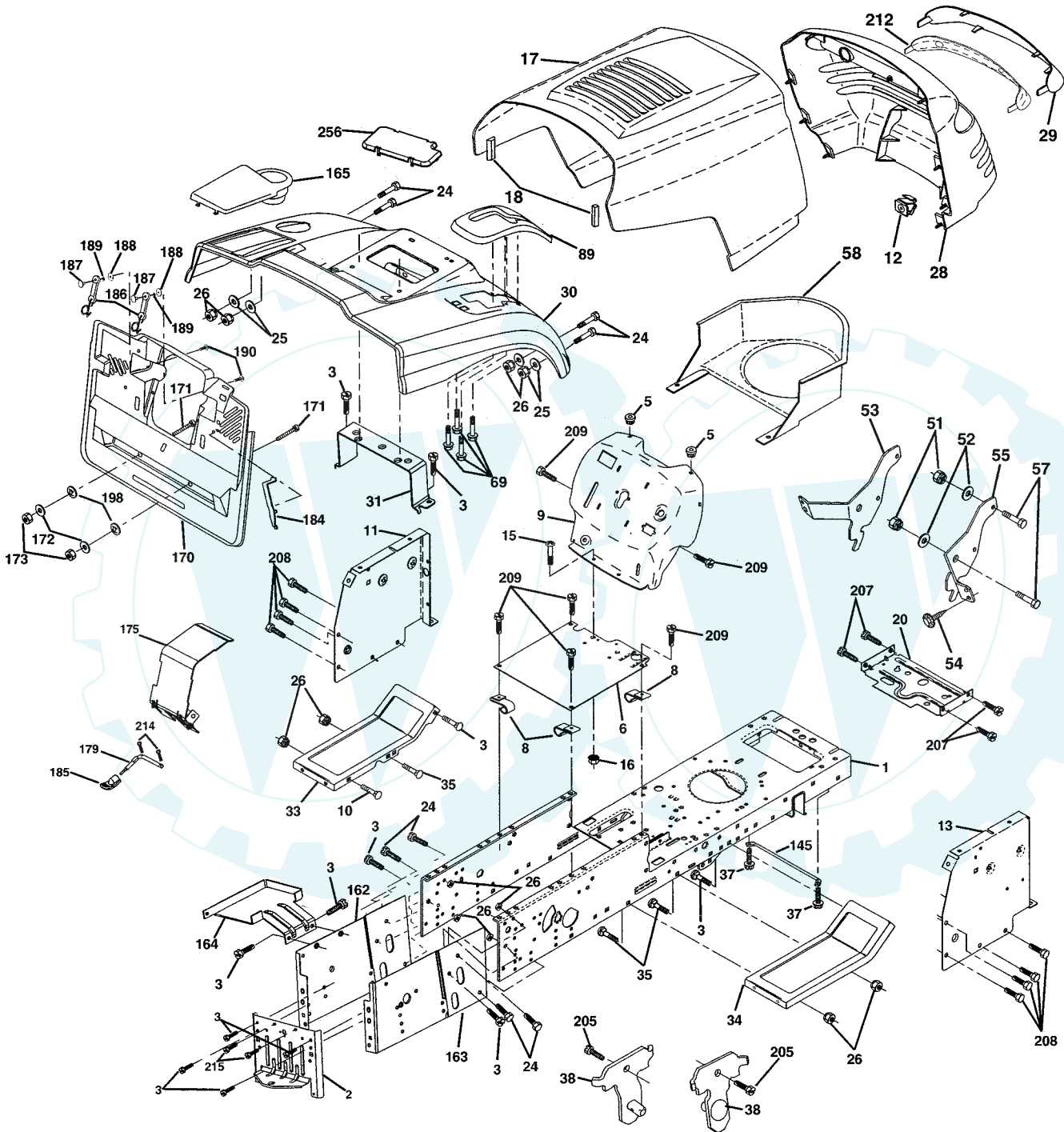

REPAIR PARTS

www.ersatzteil-service.de

TRACTOR- -MODEL NO. RER155H42E

CHASSIS AND ENCLOSURES

KEY NO.	PART NO.	DESCRIPTION	KEY NO.	PART NO.	DESCRIPTION
1	174620	Chassis	57	74780412	Bolt fin Hex 1/4-20 Unc x .75
2	180384	Drawbar	58	150127	Duct Air Engine
3	17060612	Screw 3/8-16 x 3/4	69	142432	Screw Hex Wsh
5	155272	BumperHood/Dash	89	177287X428	Console
6	155923	Saddle	145	156524	Rod Pivot Chassis/Hood
8	126471X	Clip Insulator 13/32 Mtg. Hole	162	180382	Bracket Exten Chassis Lh CRD
9	168347X011	Dash	163	180383	Bracket Exten Chassis Rh CRD
10	72140608	Bolt, Carriage 3/8-16 x 3/4	164	165605	Support Battery CRD
11	155927	Panel, Dash, L.H.	165	179020X428	Cover Battery
12	145660	Clip Tinnerman	170	178862	Backplate Asm CRD
13	172107X010	Panel, Asm. Dash R.H.	171	72140620	Bolt Rdhd Sqnk 3/8-16 x 2-1/2 Gr. 5
15	74180512	Screw, Machine, Truss Head 5/16-18 UNC x 3/4	172	19132016	Washer 13/32 x 1-1/4 x 16 Ga.
16	73510500	Nut	173	73510600	Nut, Keps Hex 3/8-16 UNC
17	159639X505	Hood	175	180310	Guard Trap
18	126938X	BumperHood	179	180376	Rod Pivot FBI CRD
20	180679	Plate Mtg Battery/Tank Fuel	184	174662	Bracket Actuator Bagger CRD
24	74780616	Bolt	185	179608X505	Knob Rod Brake Parking
25	19131312	Washer 13/32 x 13/16 x 12 Gauge	186	160793	Latch Asm Mulch/Bagger
26	73800600	Nut	187	2029J	Nut Weld
28	179101	Grille /Lens Asm	188	19061216	Washer #10
29	140273X599	Lens, Grille	189	10071000	Washer Lock #10
30	169962X505	Fender	190	71081010	Screw Pan Hd Phillip 10-24 x 5/8
31	165156	Bracket, Fender Support	198	168937	Nut, Push
33	179716X505	Footrest, L.H.	205	17490608	Screw Thdrol 3/8-16 x 1/2
34	179717X505	Footrest, R.H.	207	17670508	Screw Thdrol 5/16-18 x 1/2
35	72110606	Bolt	208	17670608	Screw Thdrol 3/8-16 x 1/2
37	17490508	Screw Thdrol 5/16-18 x 1/2 TYT	209	17000612	Screw Hex Wsh Thdrol 3/8-16
38	175710	Bracket Asm Pivot Mower Rear	212	156229	Insert Lens Reflective
51	73800400	Nut Lock w/Insert 1/4-20 Unc	214	4497H	Retainer Spring
52	19091416	Washer 9/32 x 7/8 x 16 Ga.	215	17060508	Screw 5/16-18 x 1/2
53	144697	Bracket Grille LH	256	180810X428	Cover Fender Rack CRD
54	161464	Screw Hex Wshd 8-18 x 7/8	--	5479J	Plug, Button
55	144696	Bracket Grille RH			

NOTE: All component dimensions given in U.S. inches.
1 inch = 25.4 mm.

REPAIR PARTS

www.ersatzteil-service.de

TRACTOR- -MODEL NO. RER155H42E

DRIVE

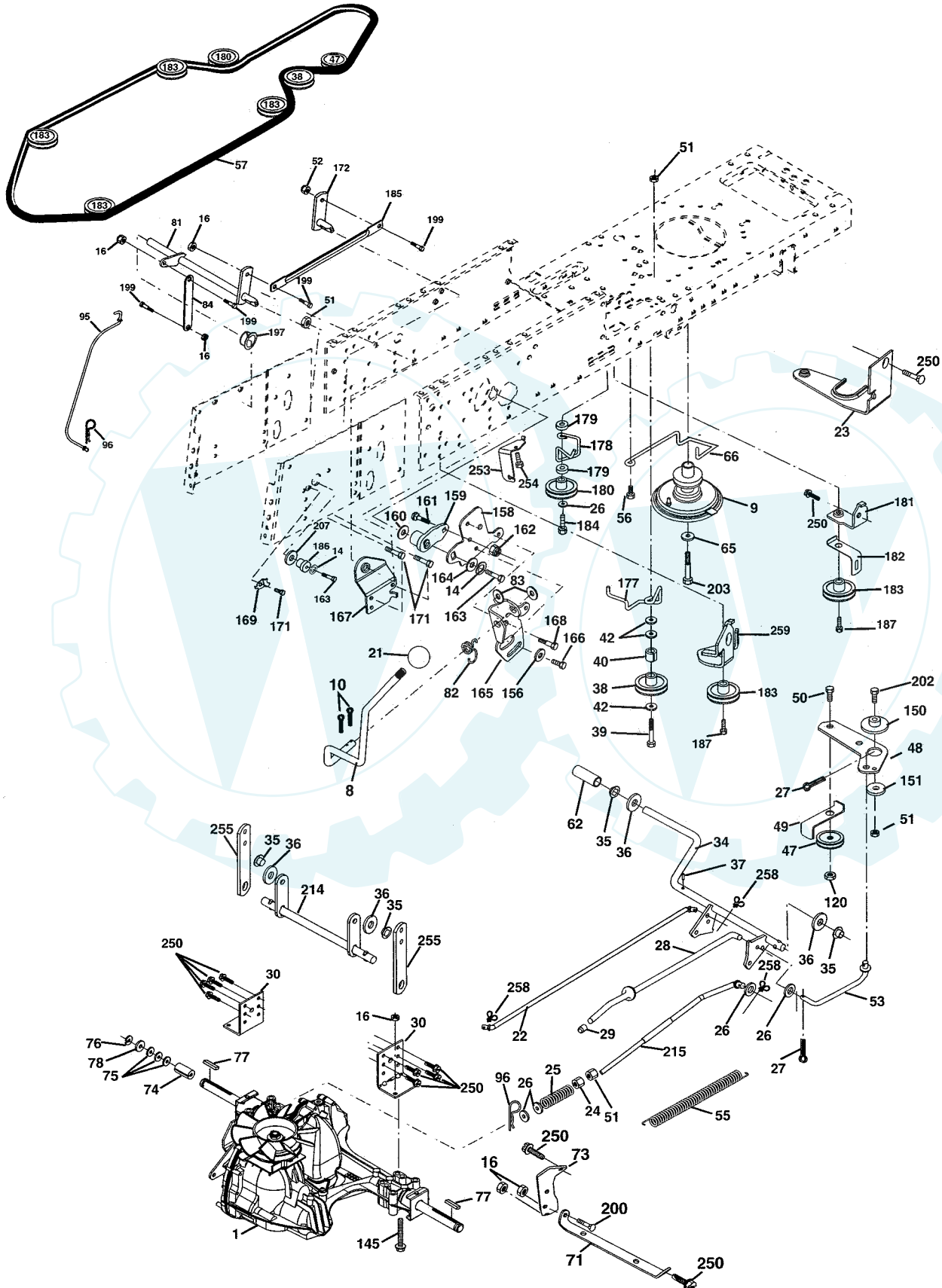

REPAIR PARTS

www.ersatzteil-service.de

TRACTOR- -MODEL NO. RER155H42E

DRIVE

KEY NO.	PART NO.	DESCRIPTION	KEY NO.	PART NO.	DESCRIPTION
1	-----	Transaxle Hydro Gear 321-0510 (Order parts from transaxle manufacturer)	95	170015	Control Asm Bypass Hydro Spring, Retainer 1"
8	165619	Rod, Shift Fender Adjust Lt	96	4497H	Nut Lock Flg. 3/8-16 Unc
9	170163	Clutch Asm	120	73900600	Nut Lock Flg. 3/8-16 Unc
10	76020416	Pin, Cotter 1/8 x 1	145	74490544	Bolt Hex FGHD 5/16-18 x Gr 5
14	10040400	Washer, Lock Hvy Helical	150	165850	Bushing, Bellcrank Grnd Dr
16	73800500	Nut, Lock Hex w/Ins 5/16-18 UNC	151	19133210	Washer 13/32 x 2 x 10 Ga.
21	106933X	Knob	156	166002	Washer Srrted 5/16ID x 1.125
22	175607	Rod, Brake	158	165589	Bracket Shift Mount
23	180302	Bracket asm Anti-Rot	159	165494	Hub Tapered Flange Shift Lt
24	73350600	Nut	160	19292016	Washer 29/32 x 1-1/4 x 16 Ga.
25	106888X	Spring, Rod, Brake	161	72140406	Bolt Rdhd Sqnk 1/4-20 x 3/4 Gr 5
26	19131316	Washer 13/32 x 13/16 x 16 Ga.	162	73680400	Nut Crownlock 1/4-20 Unc
27	76020412	Pin, Cotter 1/8 x 3/4	163	74780416	Bolt Hex Fin 1/4-20 Unc x 1 Gr 5
28	175765	Rod, Parking Brake	164	19091010	Washer 5/8 x .281 x 10 Ga.
29	71673	Cap, Parking Brake	165	165623	Bracket Pivot Lever
30	169592	Bracket, Mfg. Transaxle	166	166880	Screw 5/16-18 x 5/8
34	175578	Shaft, Asm Pedal Foot CRD	167	165588	Bracket Support Shift CRD
35	120183X	Bearing, Nylon	168	165492	Bolt Shoulder 5/16-18 x .561
36	19211616	Washer 21/32 x 1 x 16 Ga.	169	165580	Plate Fastening Lt
37	1572H	Pin, Roll 3/16 x 1"	171	17490608	Screw Thdrol 3/8-16 x 1/2 Ty-Tt
38	165936	Pulley Flat Composite 3.06"	172	170271	Shaft Asm Shifter Frt CRD
39	74760644	Bolt Fin Hex 3/8-16 Unc x 2-3/4	177	165932	Keeper Flat Idler 3.06" CRD
40	4470J	Spacer, Split 395 x 59 Bzp	178	165933	Keeper Belt Idler 1.88" CRD
42	19131312	Washer 13/32 x 13/16 x 12 Ga.	179	120958X	Washer Sintered
47	127783	Pulley, Idler, V Groove Plasic	180	165630	Pulley, Idler, Flat 1.88" CRD
48	154407	Bellcrank Clutch Grnd Drv	181	180211	Bracket Idler Ground Drive CRD
49	123205X	Retainer, Belt Style Spring	182	165634	Keeper Belt 2.5" Od V-Idler CRD
50	74760624	Bolt Hex Hd 3/8-16 UNC x 1-1/2	183	179050	Pulley V-Idler 2.50" Od CRD
51	73680600	Nut, Crownlock 3/8-16 UNC	184	17490644	Screw Hexwsh Thdrol 3/8-16 x 2-3/4
52	7368500	Nut Crownlock 5/16-18	185	170008	Link Shift
53	105710X	Link, Clutch 7.66	186	165614	Hub Tapered Round CRD
55	105709X	Spring, Return, Clutch	187	17580520	Screw Thdrol 5/16-18 x 1.25
56	17060620	Screw 3/8-16 x 1-1/4	197	169613	Nyliner Snap-In 5/8
57	170140	V-Belt Kev 112" 0650 CRD	199	169612	Bolt Shoulder 5/16-18 Unc
62	8883R	Cover, Pedal	200	72140508	Bolt RDHD SQNK 5/16-18 x 1
65	10040700	Washer	202	72110612	Bolt Carr. Sh. 3/8-16 x 1-1/2 Gr. 5
66	154778	Keeper, Belt Engine F-Proof	203	71170780	Bolt Hex 7/16-20 x 5
71	169183	Strap, Torque, Lh	207	169845	Washer Nylon Rear
73	169182	Strap, Torque, Rh	214	175609	Shaft Asm. Brake
74	137057	Spacer, Split	215	175652	Rod Brake Hydro
75	121749X	Washer 25/32 x 1-1/4 x 16 Ga.	250	17070612	Screw 3/8-16 x .75
76	12000001	Ring, E	253	175028	Bracket Cable Chassis
77	123583X	Key, Square	254	17060616	Screw 3/8-16 x 1
78	121748X	Washer 25/32 x 1-5/8 x 16 Ga.	255	175608	Brace Shaft Brake Mtg.
81	170006	Asm, Shaft	258	178062	Clip Retainer
82	165711	Spring, Torsion	259	180212	Bracket Pulley
83	19171216	Washer 17/32 x 3/4 x 16 Ga.			
84	170007	Link, Transaxle			

NOTE: All component dimensions given in U.S. inches
1 inch = 25.4 mm

REPAIR PARTS

www.ersatzteil-service.de

TRACTOR- -MODEL NO. RER155H42E

STEERING ASSEMBLY

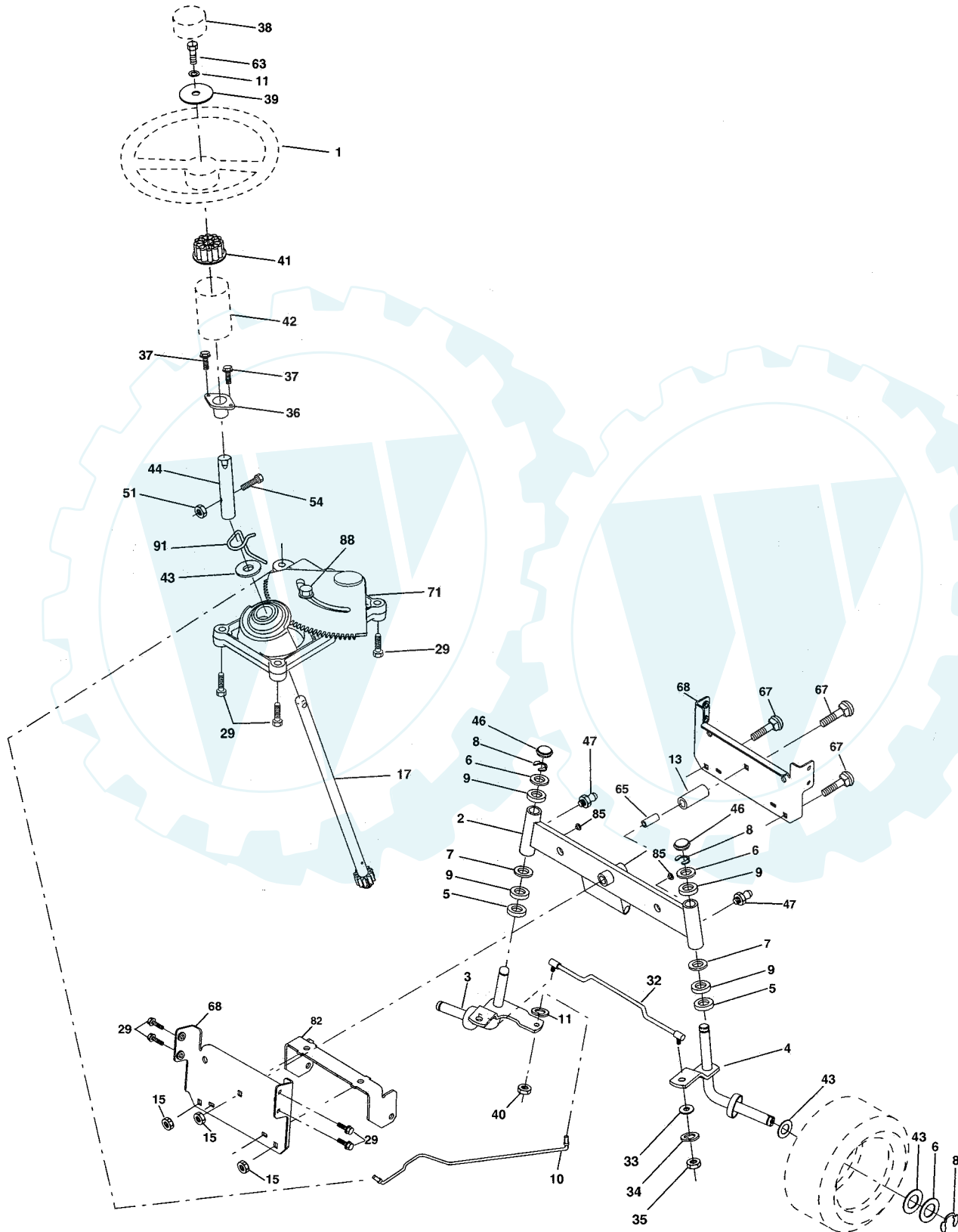

TRACTOR- -MODEL NO. RER155H42E

STEERING ASSEMBLY

KEY NO.	PART NO.	DESCRIPTION
1	133741X428	Steering Wheel
2	172393	Axle Asm Cast Iron Lt
3	169840	Spindle Assembly, L.H.
4	169839	Spindle Assembly, R.H.
5	6266H	Washer, Thrust .75 x 1.230
6	121748X	Washer 25/32 x 1-5/8 x 16 Gauge
8	1200029	Ring, Klip
10	175121	Link, Drag
11	10040600	Washer, Lock
13	136518	Spacer Brg Axle Front
15	145212	Nut, Hex Flange Lock
17	177876	Shaft Assembly, Steering
29	17060612	Screw 3/8-16 x 3/4
32	170162	Rod, Tie
33	19111216	Washer 11/32 x 3/4 x 16 Ga.
34	10040500	Washer Lock Hvy Hlcl Spr 5/16
35	73540500	Crownlock Nut 5/16-24 Unf
36	155099	Bushing, Steering
37	152927	Screw TT #10-32 x 5 x 3/8 Flange
38	133742X428	Cap Wheel Steering
39	19133812	Washer 13/32 x 2-3/8 x 12 G
40	7810H	Nut Lock Center 3/8-24 Unf
41	100711L	Adaptor, Steering Wheel
42	145054X428	Boot, Steering Dash P/L Mtl
43	121749X	Washer 25/32 x 1-1/4 x 16 Gauge
44	153720	Extension Steering
46	121232X	Cap, Spindle
51	73800500	Nut Lock Hex 5/16-18
54	74780520	Bolt Fin Hex 5/16-18 x 1-1/4
63	74780616	Bolt Fin Hex 3/8-16 Unc x 1 Gr. 5
65	160367	Spacer Brace Axle
67	72140618	Bolt Rdhd Sq 3/8-16 x 2-1/4
68	169827	Brace Axle
71	175146	Steering Asm.
82	169835	Bracket Susp Chassis Front 15"
87	173966	Washer Flat .781 x 1-1/2 x .14
88	175118	Bolt Shoulder 7/16-20 UNC
91	175553	Clip Steering

NOTE: All component dimensions given in U.S. inches.
1 inch = 25.4 mm.

REPAIR PARTS

TRACTOR- -MODEL NO. RER155H42E

SEAT ASSEMBLY

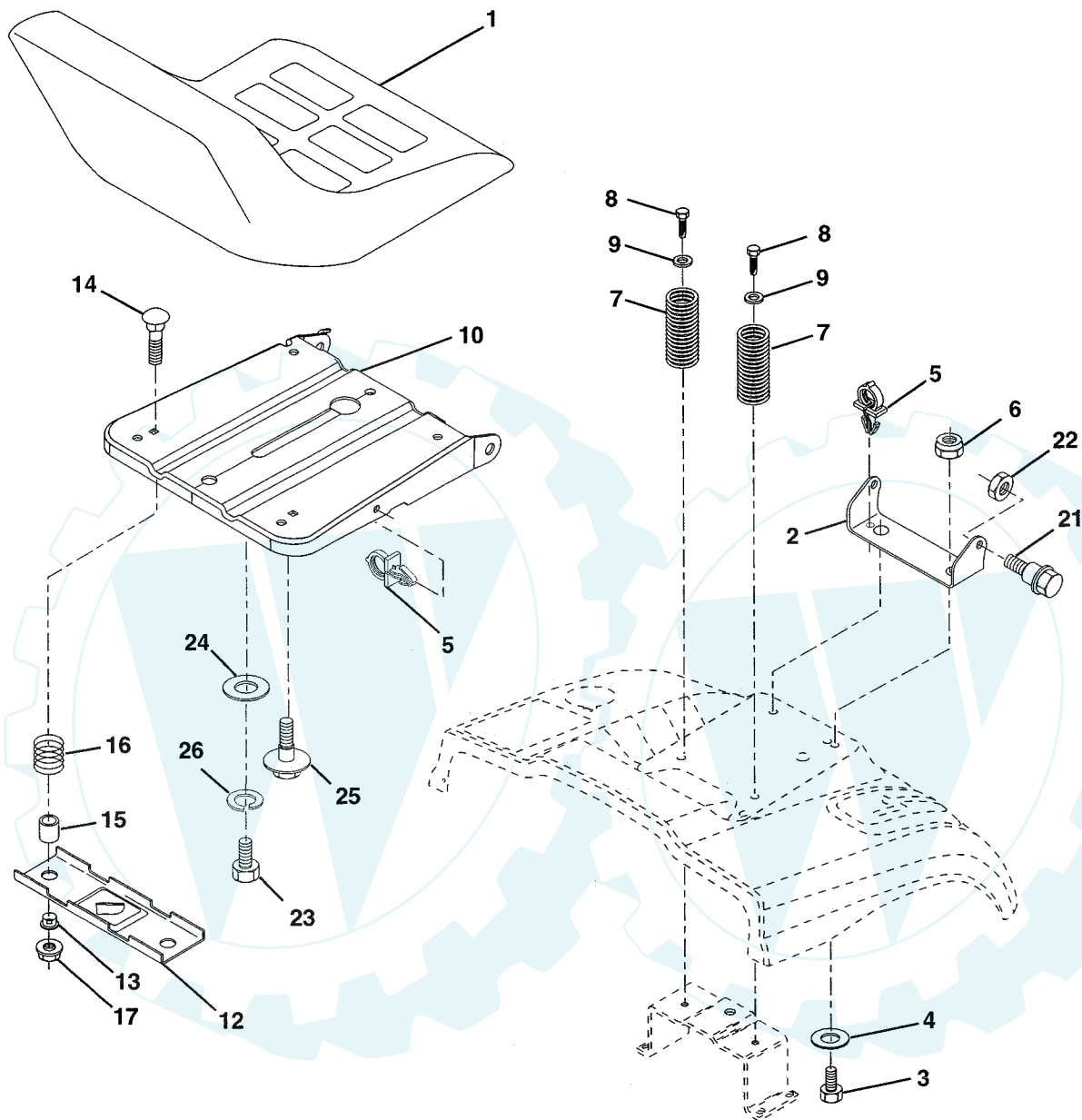

KEY NO.	PART NO.	DESCRIPTION
1	175390	Seat
2	140551	Bracket Pnt Pivot Seat (blk)
3	71110616	Bolt Fin Hex 3/8-16 Unc x 1
4	19131610	Washer Flat 13/32 x 1 x 10 Ga.
5	145006	Clip Push In Hinged
6	73800600	Nut Lock Hex w/Ins 3/8-16 Unc
7	124181X	Spring Seat Cprsn 2 250 Blk Zi
8	17000616	Screw 3/8-16 X 1-1/2
9	19131614	Washer 13/32 X 1 X 14 Ga
10	174894	Pan Assembly Seat Tool-Free
11	166369	Knob Seat Adj. Wingnut
12	121246X	Bracket Pnt Mounting Switch

KEY NO.	PART NO.	DESCRIPTION
13	121248X	Bushing Snap Blk Nyl 50 Id
14	72050412	Bolt Rdhd Sht Nk 1/4-20x1-1/2
15	121249X	Spacer Split
16	123740X	Spring Cprsn Plate SW 1.310 Ga
17	123976X	Nut Lock 1/4 Lge Flg Gr 5 Zinc
21	171852	Bolt Shoulder 5/16-18 Unc-2A
22	73800500	Nut Hex Lock w/Ins 5/16-18
24	19171912	Washer 17/32 X 1-3/16 X 12 Ga.
25	127018X	Bolt Shoulder 5/16-18 X 62

NOTE: All component dimensions given in U.S. inches.
1 inch = 25.4 mm

REPAIR PARTS

TRACTOR- -MODEL NO. RER155H42E

ENGINE

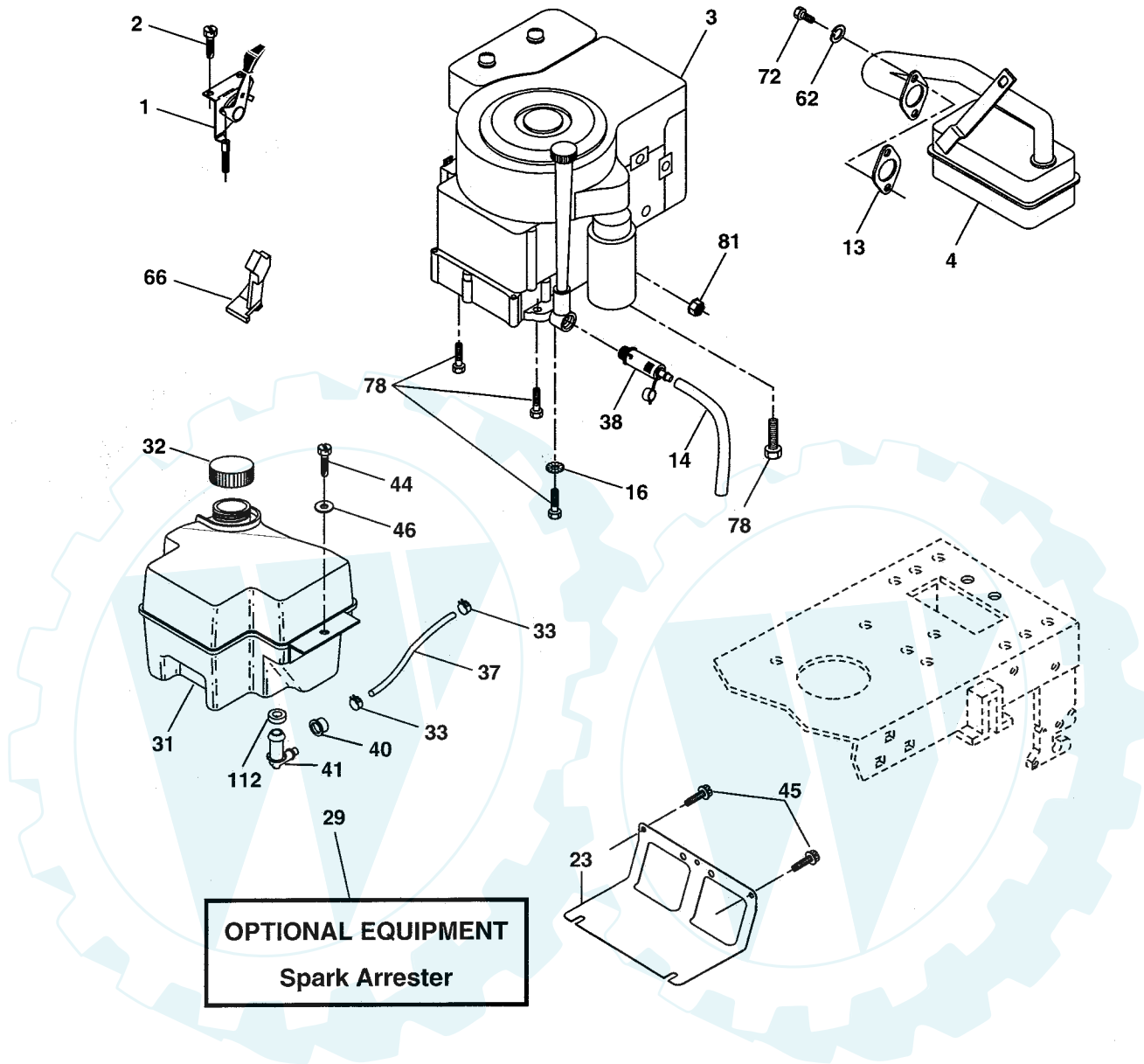

KEY NO.	PART NO.	DESCRIPTION
1	170865	Control Throt/Ch
2	17720408	Screw Hex Thd Cut 1/4-20 x 1/2
3	-----	Engine Briggs Model 28U707 (Order Parts from Engine Manufacturer)
4	137352	Muffler Exhaust B&S Lt
13	165291	Gasket 1 313 Id Tin Plated
14	148456	Tube Drain Oil Easy
15	13200300	Elbow
16	11050600	Washer Lock Ext Tooth 3/8
23	169837	Shield Browning/Debris Guard
29	137180	Arrestor Spark
31	180645	Tank Fuel
32	140527	Cap Asm Fule Top Vent N/Lany
33	123487X	Clamp Hose Blk

KEY NO.	PART NO.	DESCRIPTION
37	137040	Line Fuel 20"
38	148315	Plug Drain Oil Easy
40	124028X	Bushing Snap
41	139277	Stem Tank Fuel
44	17670412	Screw Hexwsh Thdrol 1/4-20x3/4
45	17000612	Screw Hexwsh Thdrol 3/8-16 x 3/4
46	19091416	Washer 9/32 X 7/8 X 16ga
62	10040500	Washer Lock Hvy Hlcl Spr 5/16
66	127951	Stop Throttle
72	71070512	Screw Hex Hd Cap 5/16-18 x 3/4
78	17060620	Screw 3/8-16x1-1/4
81	73510400	Nut Keps Hex 1/4-20 Unc
112	3645J	Bushing

NOTE: All component dimensions given in U.S. inches
1 inch = 25.4 mm

REPAIR PARTS

www.ersatzteil-service.de

TRACTOR- -MODEL NO. RER155H42E

MOWER LIFT

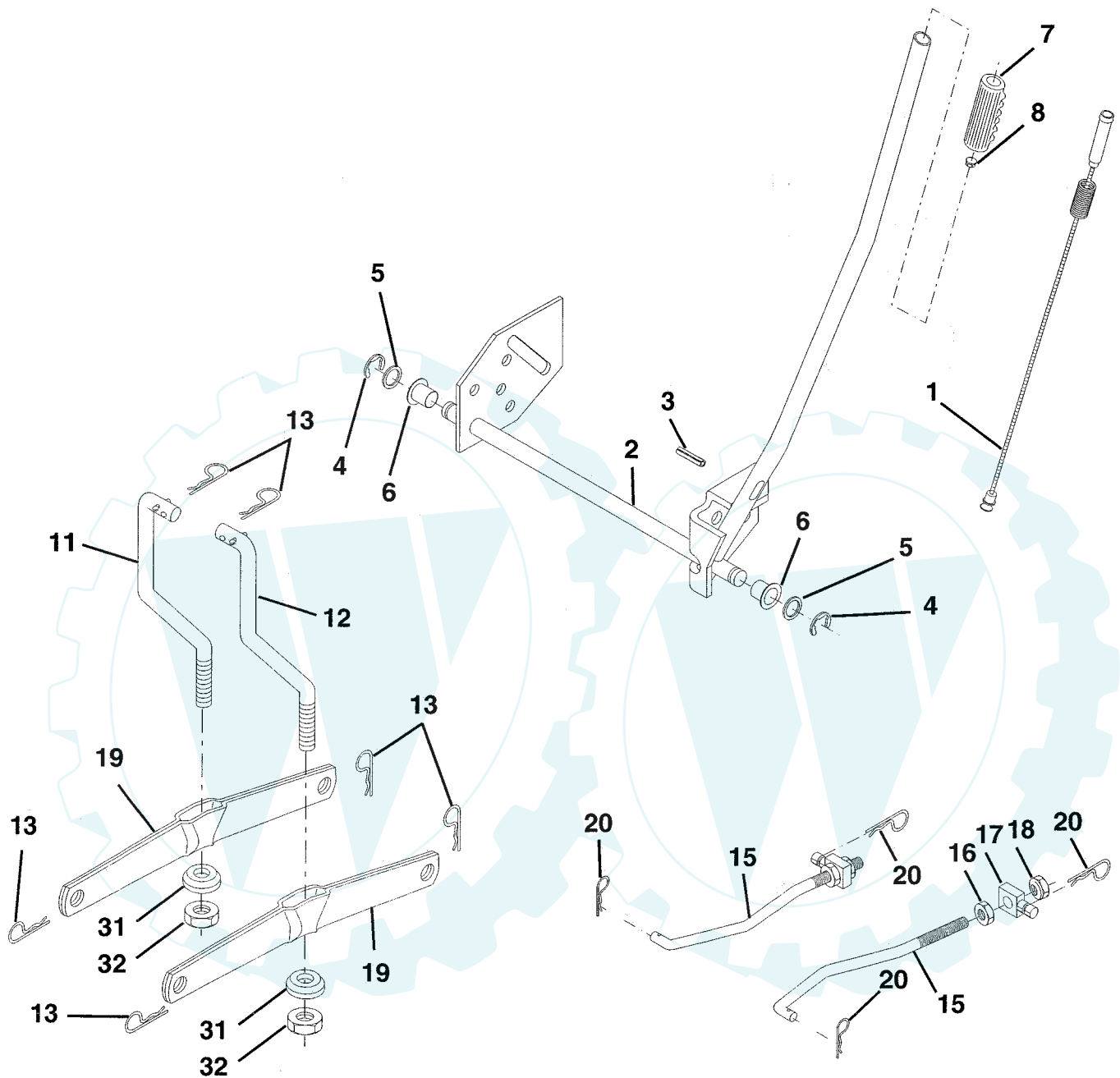

KEY NO.	PART NO.	DESCRIPTION
1	159460	Washer Asm Inner Spring W/Plunger
2	159471	Shaft Asm. Lift
3	105767X	Pin Groove
4	12000002	E Ring #5133-62
5	19211621	Washer 21/32 x 1 x 21 Ga.
6	120183X	Bearing Nylon
7	109413X	Grip Handle
8	124526X	Button Plunger Black
11	165829	Link Asm Lift L.H.
12	165831	Link Asm Lift R.H.

KEY NO.	PART NO.	DESCRIPTION
13	4939M	Retainer Spring
15	173288	Link Front
16	73350800	Nut Jam Hex 1/2-13 Unc
17	175689	Trunnion
18	73800800	Nut Lock w/Wsh 1/2-13 Unc
19	139868	Arm Suspension Mower
20	163552	Retainer Spring
31	169865	Bearing, Pvt. Lift.
32	73540600	Nut Crownlock 3/8-24

NOTE: All component dimensions given in U.S. inches
1 inch = 25.4 mm

REPAIR PARTS

www.ersatzteil-service.de

TRACTOR- -MODEL NO. RER155H42E

MOWER

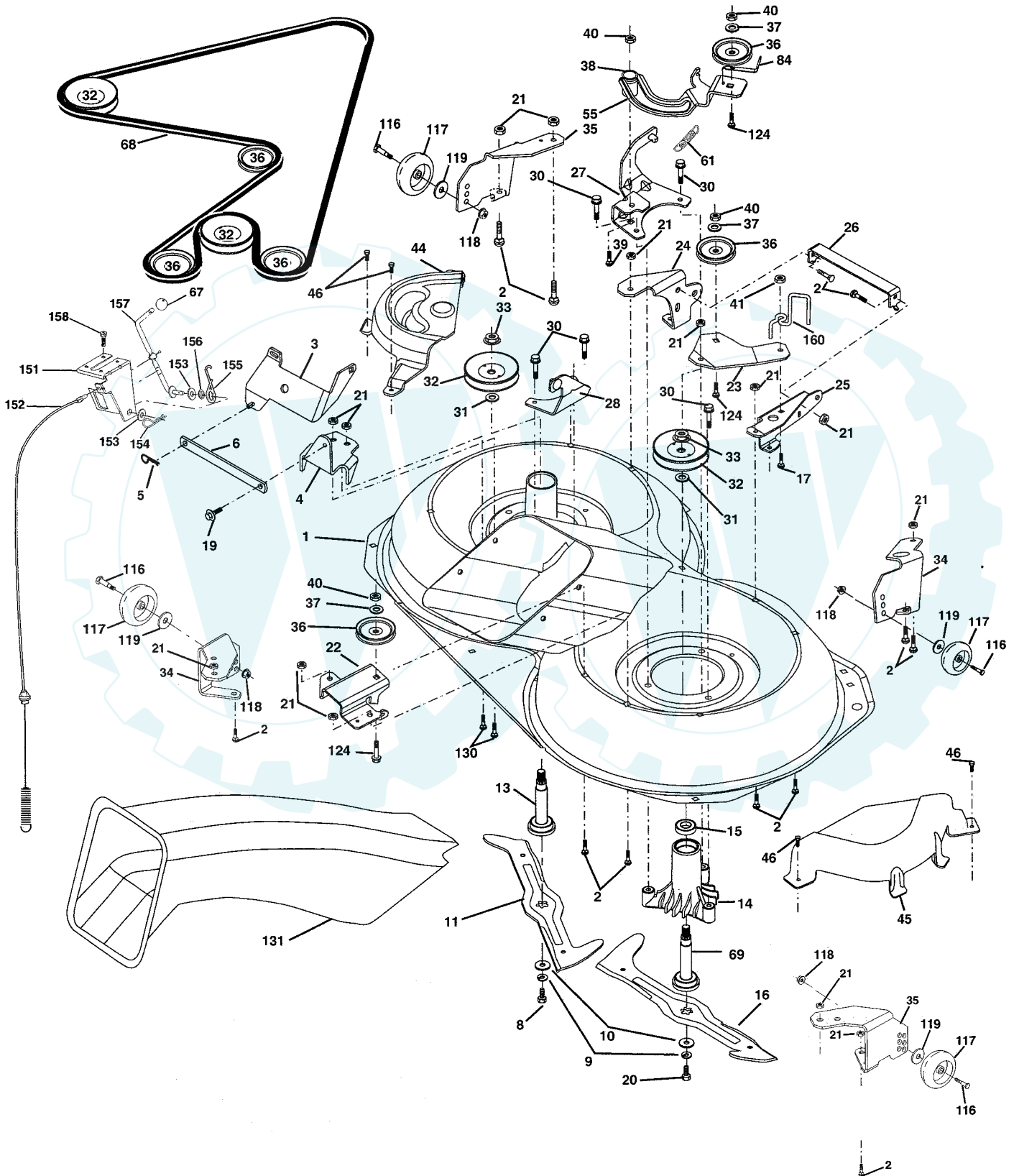

TRACTOR- -MODEL NO. RER155H42E

MOWER

KEY NO.	PART NO.	DESCRIPTION	KEY NO.	PART NO.	DESCRIPTION
1	169160	Housing Asm. Mower	39	72110622	Bolt RhHd 3/8-16 Unc x 2-3/4 Gr.5
2	72140506	Bolt Rdhd Sqnk 5/16-18 Unc x 3/4	40	73680600	Nut Crownlock 3/8-16 Unc
3	165569	Bracket Asm. S-Bar Chass	41	73900600	Nut Lock Flg 3/8-16
4	169167	Bracket Bar Sway Deck	44	175538	Cover Mandrel Lh
5	4939M	Retainer Spring	45	175539	Cover Mandrel Rh
6	165557	Bar Sway	46	137729	Screw Thd Roll 1/4-20 x 5/8
8	850857	Bolt 3/8-24 x 1.25 Gr8 Patched	55	169849	Arm Idler
9	10030600	Washer Lock Hvy 3/8 Unplated	61	175159	Spring Tension Belt
10	140296	Washer Hard Blade Mower vented	67	106932X	Knob Rd 3/8-16 Plstc Thds Blk
11	175450	Blade 3-1 Lh	68	169178	Hex-Belt Mower
13	137645	Shaft Asm. W/Lower Bearing	69	165482	Shaft Asm W/Lwr Brg Rh Thd CRD
14	128774	Housing Mandrel Vented (Machd)	84	156085	Keeper Belt Idler
15	110485X	Bearing Ball Mandrel	116	137644	Bolt Shoulder
16	175451	Blade 3-1 Rh	117	133957	Wheel Gage Donut Wide
17	72140610	Bolt Carr 3/8-16 x 1-1/4	118	73930600	Nut Centerlock 3/8-16 Unc
19	132827	Bolt Shoulder 5/16-18 Thd Form	119	19121414	Washer 3/8 x 7/8 x 14 Ga.
20	165484	Bolt 3/8-24 x 1.25 Gr8 Ptch Lhthd	124	72110612	Bolt Carr Sh 3/8-16 x 1-1/2 Gr5
21	73680500	Nut Crown Lock 5/16-18	130	72110506	Bolt Rdhdsqnk 5/16-18 Unc x 3/4
22	169165	Bracket Idler Sprt RR	131	165661	Chute Bagger CRD 92cm
23	169166	Bracket Idler Sprt RF	151	169670	Bracket Clutch Cable
24	169170	Bracket Suspension LF	152	176074	Clutch Cable
25	169171	Bracket Suspension RF	153	169674	Washer Flat 3/8" Type B
26	165237	Brace Support Susp Frit CRD	154	169675	Spring Retainer
27	169172	Bracket Asm. Susp RR	155	169671	Spring Retention Lvr Cltch Cab
28	169168	Bracket Asm. Susp LR	156	169672	Spacer Clutch Cable
30	173984	Screw Thd Rolling	157	169669	Rod Clutch Cable 3/8"
31	129963	Washer Spacer Mower Vented	158	17720408	Screw Hex Thd Cut 1/4-20 x 1/2
32	175707	Mandrel Pulleys	160	175160	Guide Belt
33	178342	Nut Flg Top Lock	--	130794	Mandrel Asm Service
34	176292	Bracket Gauge Wheel RF/LR	--	165579	Mandrel Asm CRD Lh Threads SVC
35	179509	Bracket Gauge Wheel LF/LR	--	180387	Deck Mower Complete
36	146763	Pulley Idler V-Groove Dim 4.25			
37	19131316	Washer 11/32 x 13/16 x 16 Ga			
38	169851	Spacer Hub Arm Idler			

NOTE: All component dimensions given in U.S. inches
1 inch = 25.4 mm

REPAIR PARTS

TRACTOR- -MODEL NO. RER155H42E

DECALS

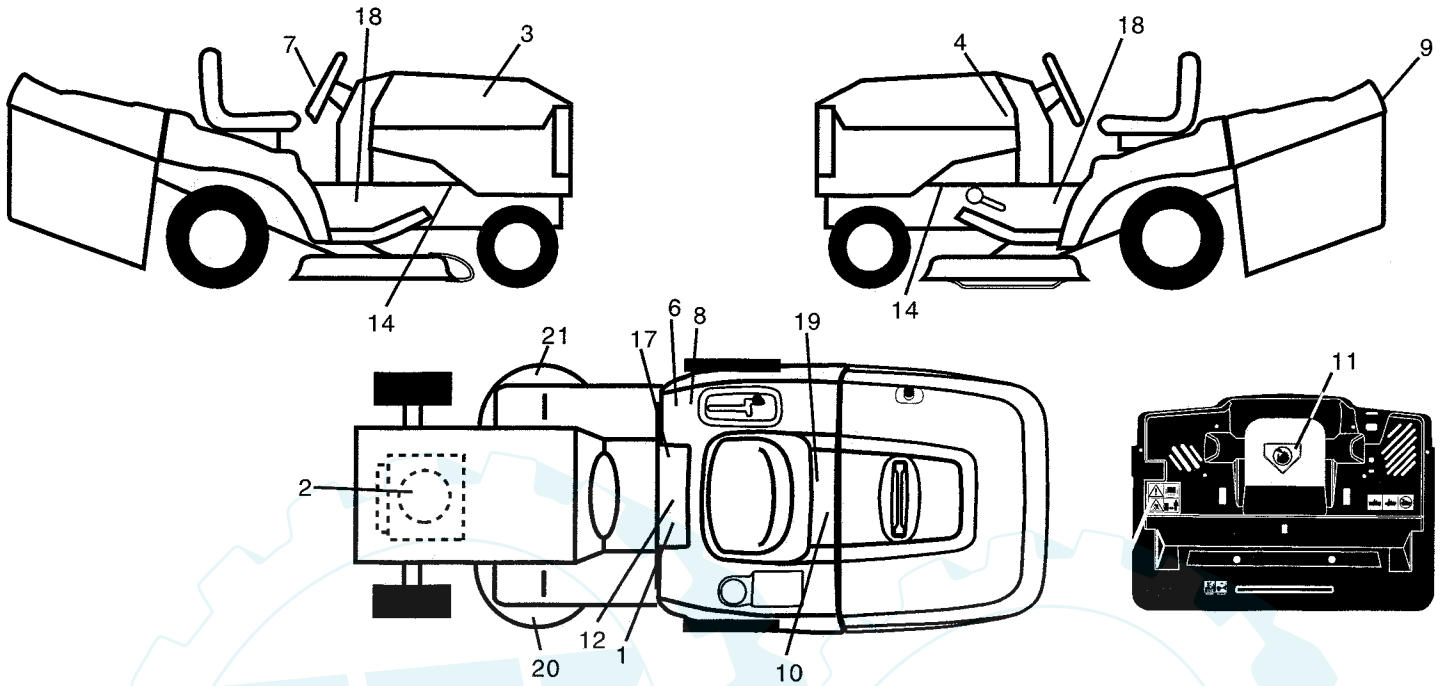

KEY NO.	PART NO.	DESCRIPTION
1	145498	Decal Read Owner's Manual Sym
2	176398	Decal Hp Engine
3	181144	Decal Hood Rh
4	181145	Decal Hood Lh
6	126187X	Decal 100 DBA
7	127075	Decal Ins Strg Whl
8	145437	Decal Europe Stand Ce
9	181146	Decal Fender Logo
10	145005	Decal Bat Dan/Poi P/L Sym Wpn
11	145494	Decal Mower Cut Finger Symbol
12	159737	Decal Brake/Clutch Symbol Lt

KEY NO.	PART NO.	DESCRIPTION
14	159736	Decal Chassis Hot Muffler
17	140837	Decal Saddle Brake Parking
18	181149	Decal Chassis
19	166960	Decal Bypass Fender
20	134999	Decal Enviro Deck
21	166286	Decal Deck Sch 92 CRD
—	138311	Decal Lift Handle
—	181518	Manual Operator's (Euro)
—	181519	Manual Operator's (Scan)
—	181520	Manual Parts

WHEELS & TIRES

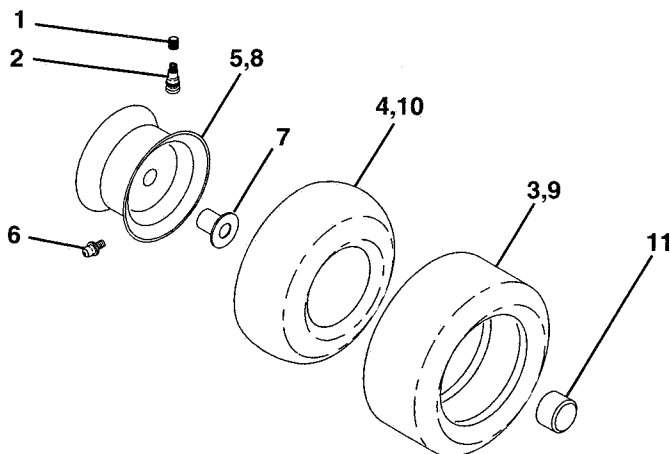

KEY NO.	PART NO.	DESCRIPTION
1	59192	Cap Value Tire
2	65139	Stem Value
3	106222X	Tire F Ts 15 X 6 0 - 6 Service
4	59904	Tube Inner Front #35060
5	106732X421	Rim Asm 6"front Service
6	278H	Fitting Grease
7	9040H	Bearing Flange
8	106108X421	Rim Asm 8"rear Service
9	124635X	Tire R Ts 18 x 8.5-8 Service
10	7152J	Tube Rear 9 5 X 8 Service
11	104757X428	Cap Axle Blk 1 50 X 1 00
--	144334	Sealant, Tire (10 oz. tube)

NOTE: All component dimensions given in U.S. inches
1 inch = 25.4 mm

REPAIR PARTS

www.ersatzteil-service.de

TRACTOR- -MODEL NO. RER155H42E

BAGGER

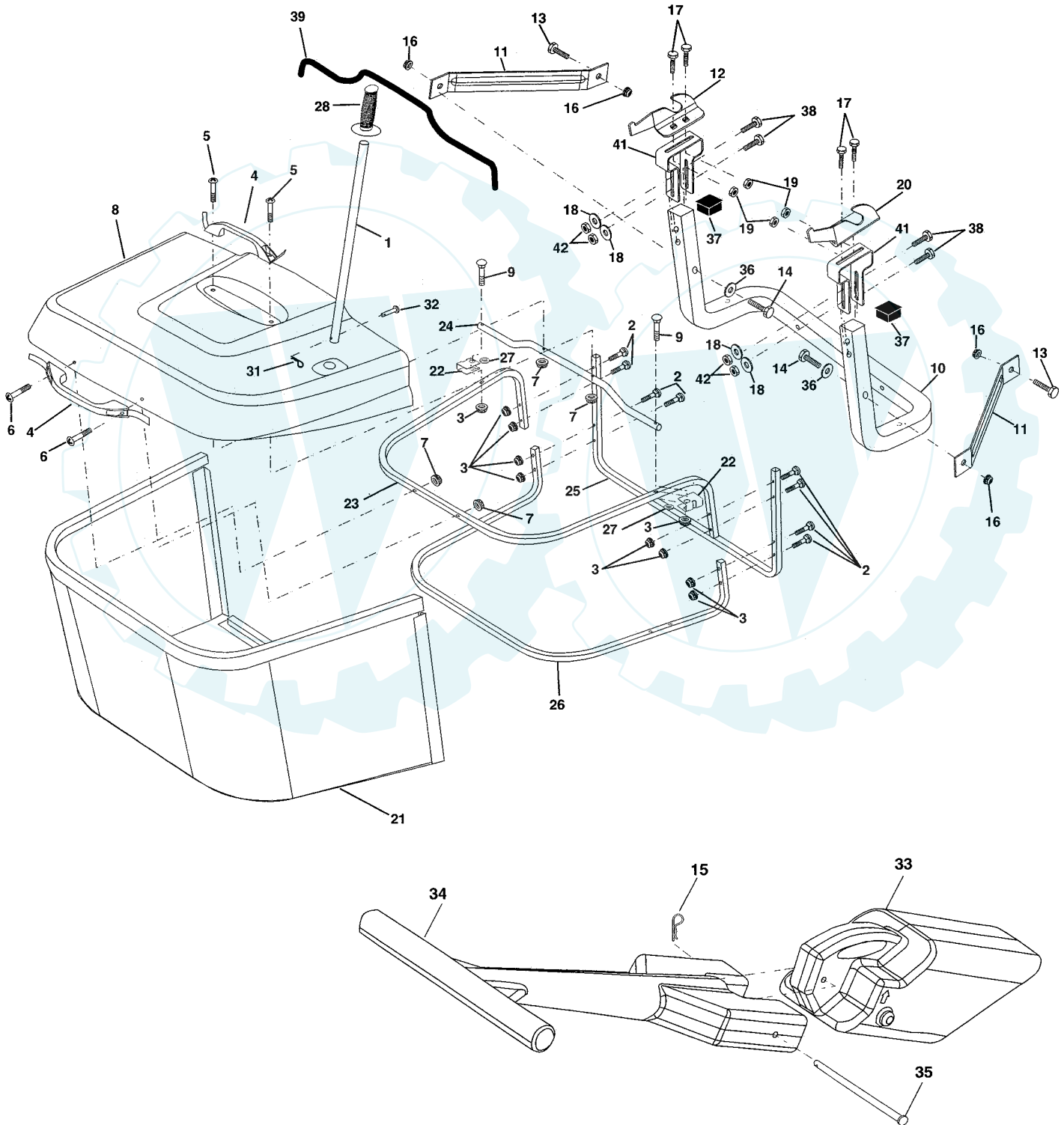

TRACTOR- -MODEL NO. RER155H42E

BAGGER

KEY NO.	PART NO.	DESCRIPTION
1	165249	Tube Handle Bagger CRD
2	72140416	Bolt Carriage 1/4-20 x 2.0 Gr.5
3	123976X	Nut Lock 1/4 Lge Fig Gr. 5 Zinc
4	169916	Handle Bagger w/Lvrs Blk CRD
5	74981024	Screw Pan Head #10-24 x 1.50 Blk
6	74981032	Screw Pan Hd
7	73401000	Nut Wiz Lock Hex Serr/Hd 10-24
8	169963X505	Cover Bagger
9	72140418	Bolt Carriage 1/4-20 x 2.25d x Gr.5
10	181282	Tube Support Bagger CRD
11	165719	Bracket Support Upper Bag CRD
12	169685	Bracket Horizon Adj Bggr Lh CRD
13	72110606	Bolt Rdhd Sht Sqnk 3/8-16 x 3/4
14	72140620	Bolt Rdhd Sqnk 3/8-16 x 2-1/2 Gr. 5
15	4939M	Retainer Spring
16	73900600	Nut Lock Flg 3/8-16 Unc
17	72140506	Bolt Rdhd Sht Sqnk 5/16 -18 Unc x 3/4
18	19111216	Washer 11/32 x 3/4 x 16
19	73900500	Nut Lock Hex Flange 5/16-18
20	169684	Bracket Horiz Adj Bggr RH CRD
21	180880	Bag Asm CRD
22	165781	Bracket Side Bagger CRD
23	165782	Tube Upper Bagger CRD
24	165783	Tube Pivot Bagger CRD
25	180124	Tube Front Bagger CRD
26	165785	Tube Lower Bagger CRD
27	169692	Bushing Snap Bagger CRD
28	165787	Grip Handle
31	4497H	Retainer Spring 1" Zinc/Cad
32	126875X	Rivet Rd Hd Drilled 3/8 Dia
33	169380	Plug Mulch
34	165570	Handle Mulcher
35	165572	Pin Mulcher
36	19132016	Washer 13/32 x 1-1/4 x 16 Ga.
37	175401	Plug Support
38	72010520	Bolt 5/16-18 x 2-1/2
39	180985	Seal Trim 37"
41	169683	Bracket Vert Adj Bagger CRD
42	73800500	Nut Lock Hx W/Ins 5/16

NOTE: All component dimensions given in U.S. inches
1 inch = 25.4 mm