

SCHEMATIC

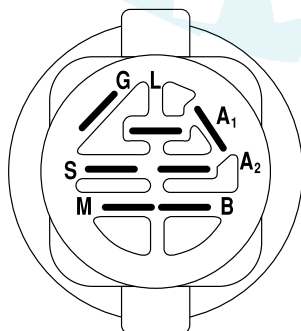
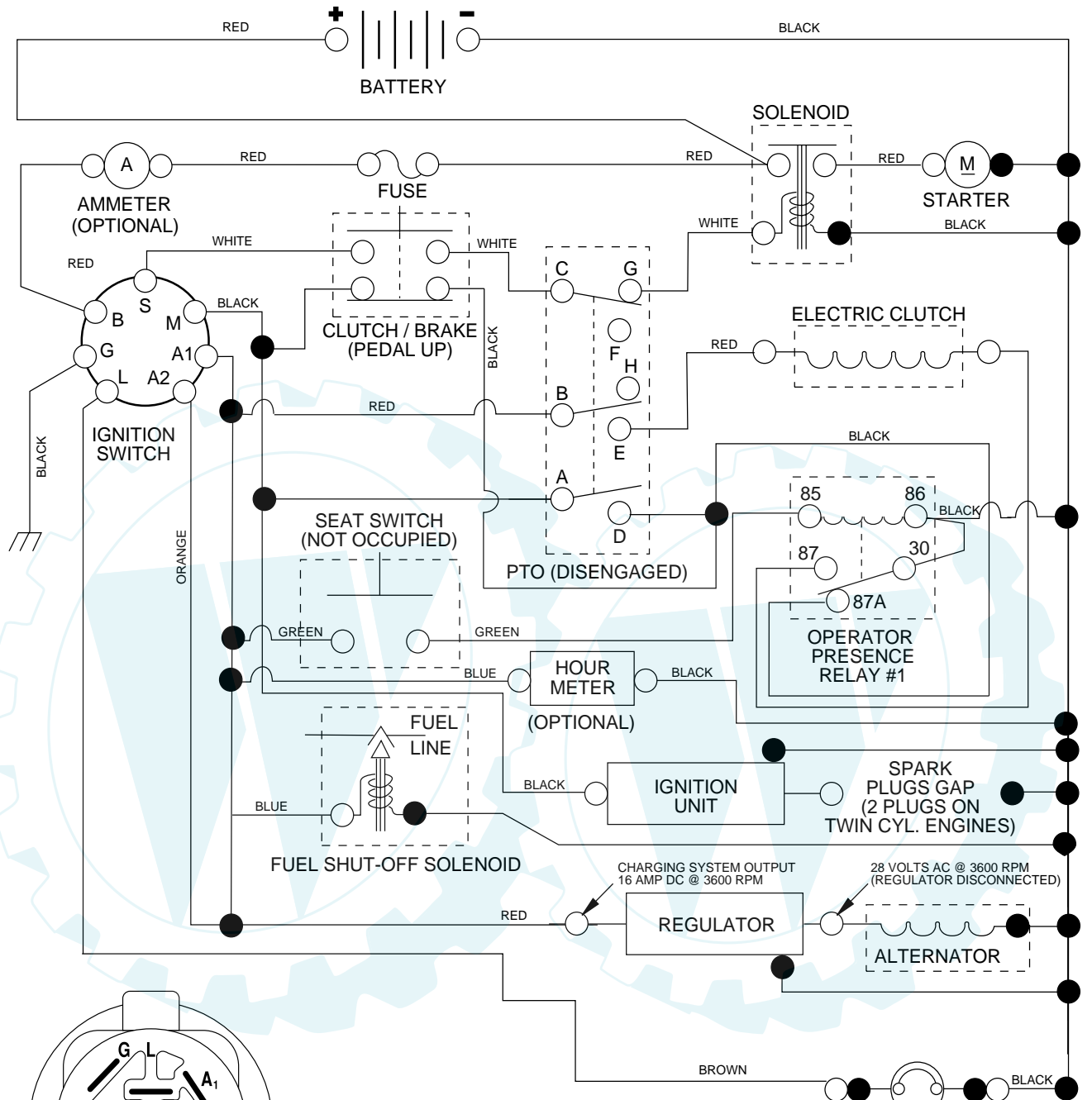

**IGNITION SWITCH**

POSITION	CIRCUIT	"MAKE"
OFF	M+G+A1	NONE
RUN/LIGHT	B+A1	A2+L
RUN	B+A1	NONE
START	B + S + A1	NONE

**WIRING INSULATED CLIPS**

**NOTE:** IF WIRING INSULATED CLIPS WERE REMOVED FOR SERVICING OF UNIT, THEY SHOULD BE REPLACED TO PROPERLY SECURE YOUR WIRING.

**PTO SWITCH**

POSITION	CIRCUIT
OFF	C + G, B + H
ON	C + F, B + E, A + D

● NON-REMOVABLE CONNECTIONS  
○ REMOVABLE CONNECTIONS

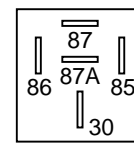

**RELAY**

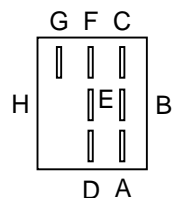

# REPAIR PARTS

[www.ersatzteil-service.de](http://www.ersatzteil-service.de)

## TRACTOR - MODEL NUMBER QP20H46B

### ELECTRICAL

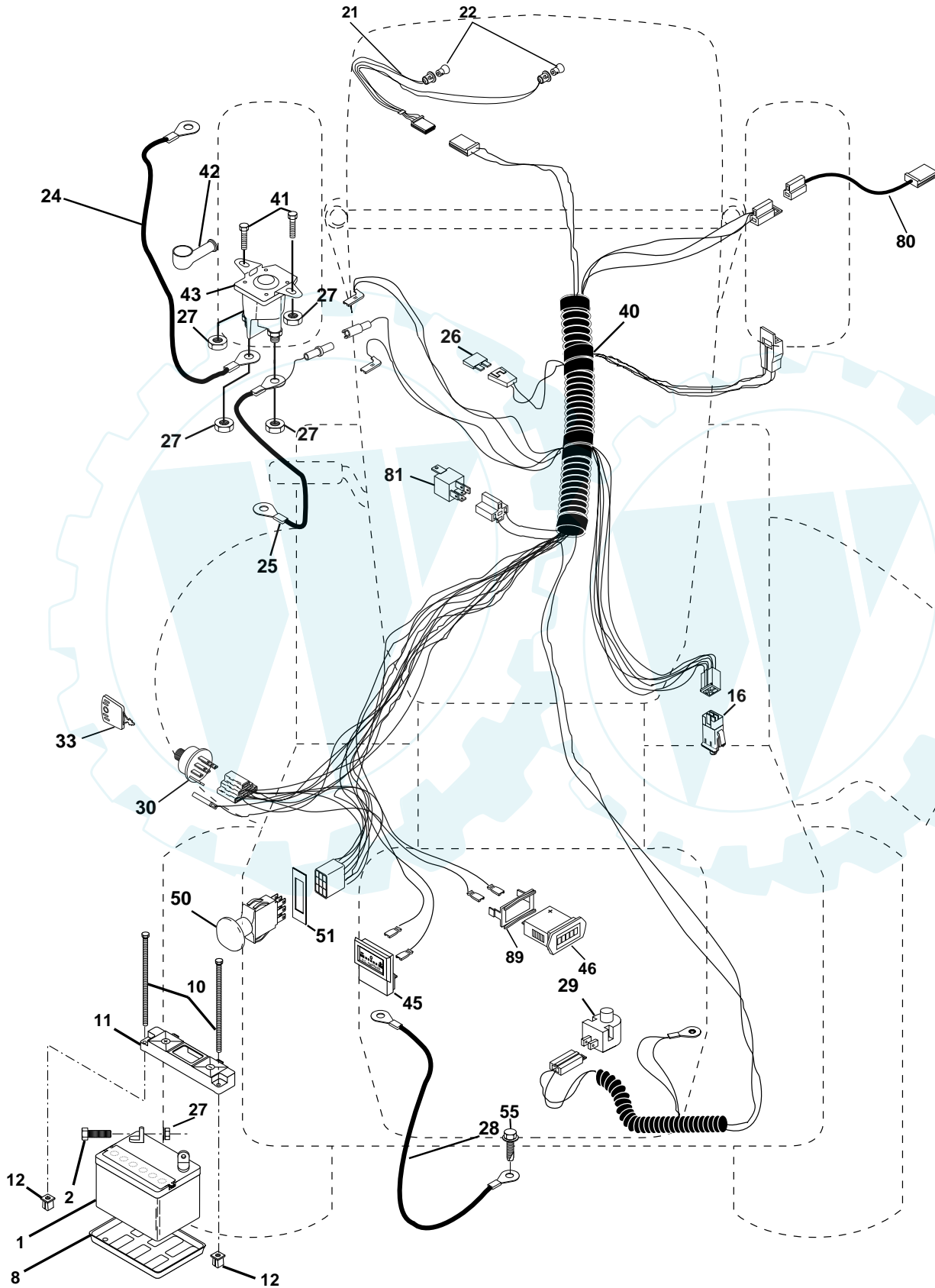

## TRACTOR - MODEL NUMBER QP20H46B

### ELECTRICAL

KEY NO.	PART NO.	DESCRIPTION
1	163465	Battery 12 Volt 28 AMP
2	74760412	Bolt Hex Hd 1/4-20 UNC X 3/4
8	7603J	Tray, Battery
10	145211	Bolt, BTR FRT 1/4-20 x 7.5
11	150109	Hold Down Battery, Front
12	145769	Nut, Push, Nylon
16	153664	Switch Interlock Push-In
21	166181	Harness Asm Light W/4152j
22	4152J	Bulb Light #1156
24	4799J	Cable Battery 6 Ga 11" red
25	146148	Cable Batterywire
26	166180	Fuse 15 AMP
27	73510400	Nut Keps Hex 1/4-20 Unc
28	145491	Cable Ground
29	160784	Switch Plunger Normal OP Olive
30	163968	Switch Ign 4 pos w/lights
33	140401	Key Ign
40	170221	Harness Ign.
41	71110408	Bolt Blk Fin Hex 1/4 - 20 x 1/2
42	131563	Cover Terminal Red
43	145673	Solenoid
45	122822X	Ammeter Rectangular
46	169635	Hourmeter Snap-In
50	169417	Switch, PTO 3PDT Black Delta
51	140405	Ring Retainer PTO
55	17490508	Screw Thdrol 5/16-18 x 1/2
80	146685	Harness, Clutch EVX
81	109748X	Relay Asm
89	169639	Bracket Snap-In

**NOTE:** All component dimensions given in U.S. inches.  
1 inch = 25.4 mm.

# REPAIR PARTS

[www.ersatzteil-service.de](http://www.ersatzteil-service.de)

## TRACTOR - MODEL NUMBER QP20H46B

### CHASSIS AND ENCLOSURES

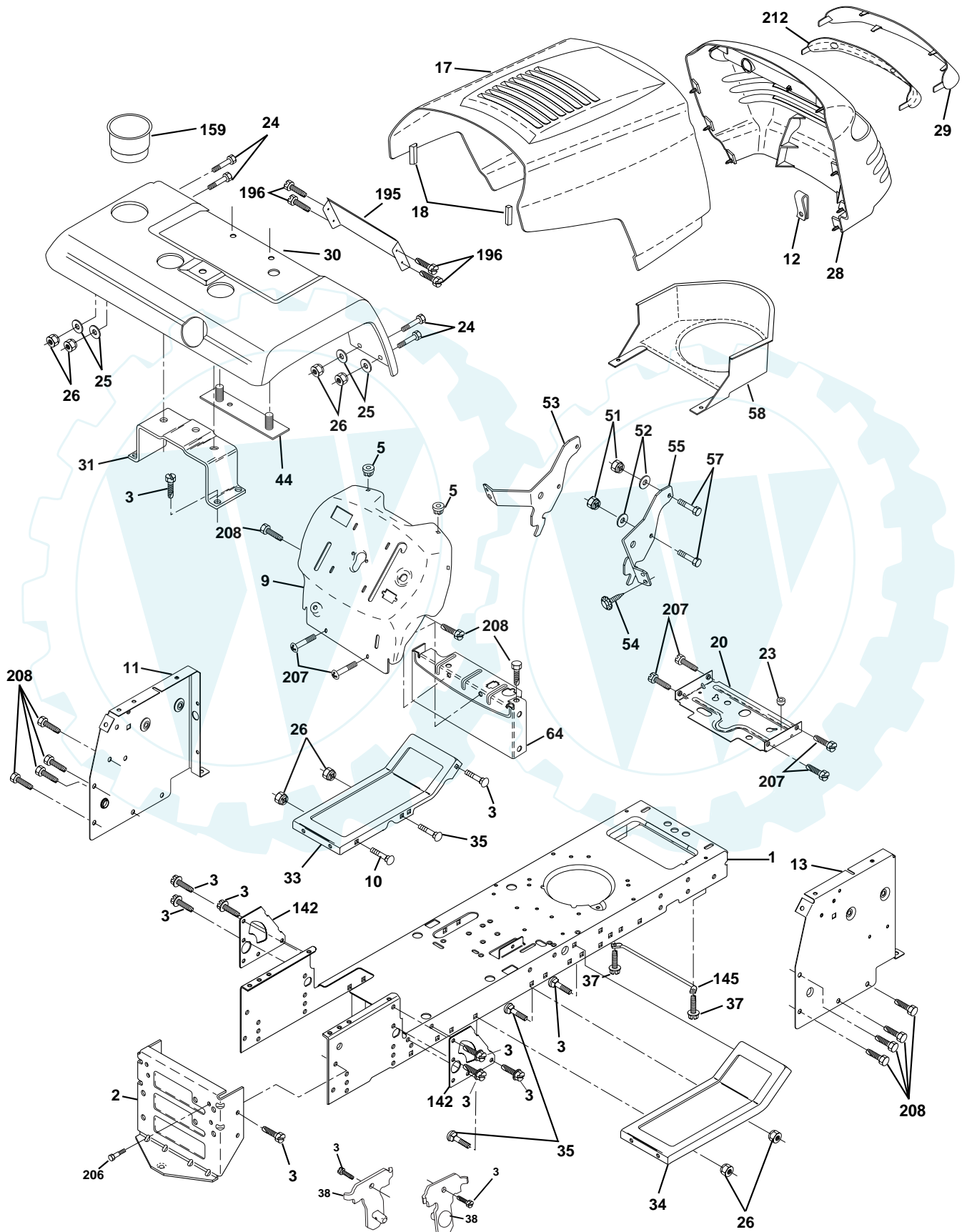

## TRACTOR - MODEL NUMBER QP20H46B

### CHASSIS AND ENCLOSURES

KEY NO.	PART NO.	DESCRIPTION
1	169830	Chassis
2	169061	Drawbar
3	17060612	Screw 3/8-16x3/4
5	155272	Bumper Hood/Dash
9	168346X011	Dash P/L
10	72140608	Bolt Carriage 3/8-16 x 1
11	155927	Panel Dash Lh
12	145660	Clip Tinnerman
13	172106	Panel Dash Rh
17	159639X428	Hood LT/PL
18	126938X	Bumper Hood
20	156437	Plate Mtg Battery Fuel Tank Fr
23	124028X	Bushing
24	74780616	Bolt Fin Hex 3/8-16 x 1 Gr 5
25	19131312	Washer 13/32 X 13/16 X 12 Ga
26	73800600	Nut Lock Hex W/Ins 3/8-16 Unc
28	157373	Grille LT/PL
29	140273X599	Lens LT/PL
30	<b>168754X428</b>	Fender Pnt YTST
31	137113	Bracket Fender
33	145244X428	Footrest Pnt Lh
34	145243X428	Footrest Pnt Rh
35	72110606	Bolt Rdhd Sht Sqnk 3/8-16 x 3/4
37	17490508	Screw Thdrol 6/16-18 x 1/2 TYT
38	169834	Bracket, Asm. Pivot Mower Rear
44	140675	Strap Asm Fender
51	73800400	Nut Lock Hex W/Ins 1/4-20
52	19091416	Washer 9/32 x 7/8 x 16 Ga.
53	144697	Bracjet Grukke Lh
54	161464	Screw Hex Wshd 8-18 x 7/8
55	144696	Bracket Grille Rh
57	74780412	Bolt Hex 1/4-20 x 3/4
58	162266	Duct Air
64	154798	Dash Lower STLT
142	165867	Plate Reinforcement STLT
145	156524	Rod Pivot Chassis/Hood
159	163975X428	Cupholder
195	166822X428	Panel Pnt Fender YT/GT
196	17580408	Screw Tap Tite 1/4-20 x 1/2
206	170165	Bolt Shoulder 5/16-18
207	17670508	Screw Thdrol 5/16-18 x 1/2
208	17670608	Screw Thdrol 3/8-16 x 1/2
212	<b>156229</b>	Insert Lens Reflect P/L LT SVC

**NOTE:** All component dimensions given in U.S. inches  
1 inch = 25.4 mm

## TRACTOR - MODEL NUMBER QP20H46B

### DRIVE

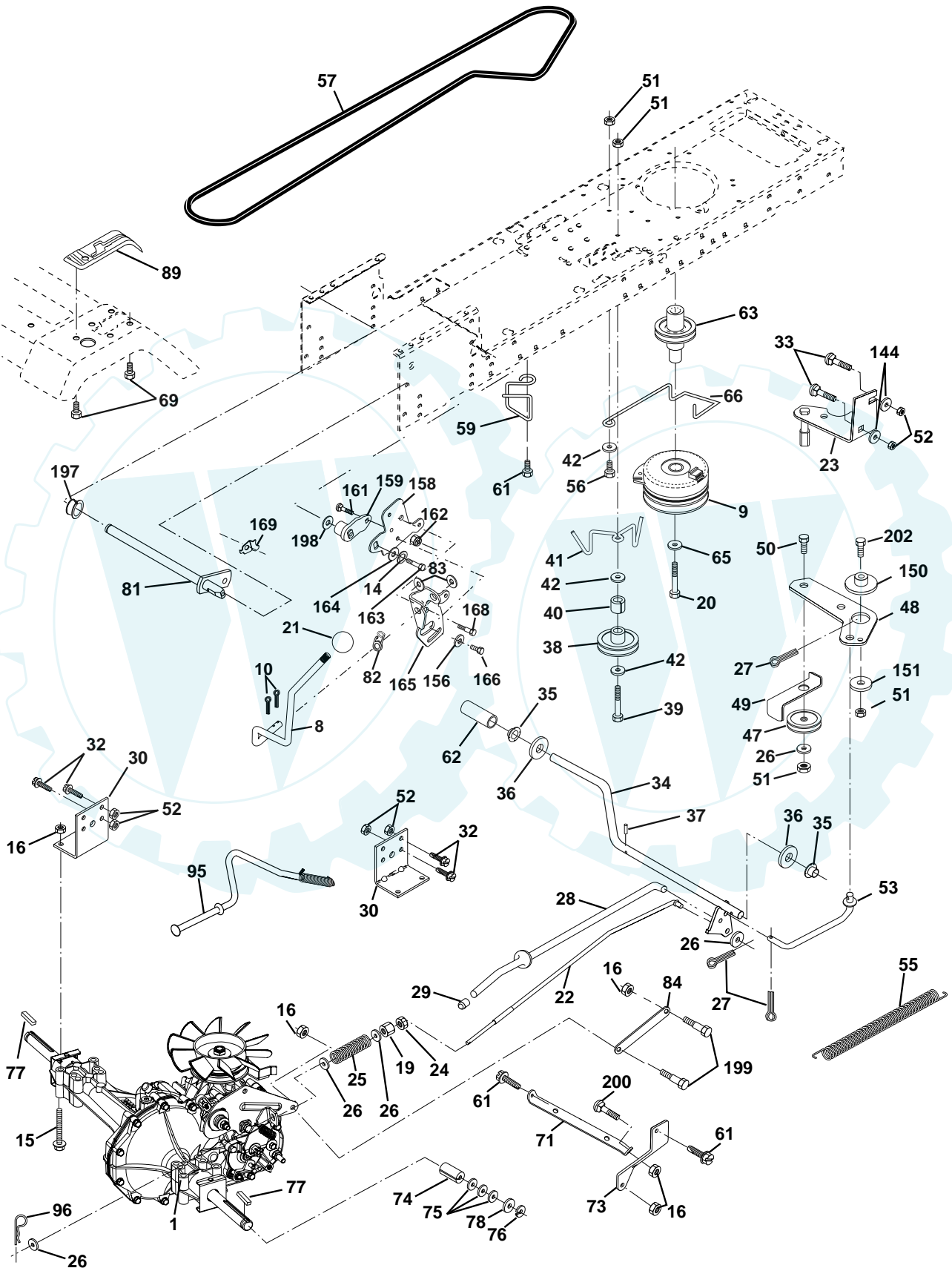

## TRACTOR - MODEL NUMBER QP20H46B

### DRIVE

KEY NO.	PART NO.	DESCRIPTION	KEY NO.	PART NO.	DESCRIPTION
1	-----	Transaxle, Hydro Gear 314-0510 (Order Parts From Transaxle Manufacturer)	59	169691	Keeper, Center Span
8	166020	Rod Shift Fender	61	17060612	Screw 3/8-16 x 3/4
9	160889	Clutch Electric	62	8883R	Cover, Pedal
10	76020416	Pin Cotter 1/8 x 1 CAD	63	145868	Pulley, Engine
14	10040400	Washer Lock Hvy Helical	65	10040700	Washer
15	74490544	Bolt Hex Flghd 5/16-18 Gr. 5	66	154778	Keeper Belt Engine Hydro
16	73800500	Nut Lock Hex W/Ins. 5/16-18 Unc	69	142432	Screw Hexwsh Hi-Lo 1/4-1/2UNC
19	73800600	Nut Lock Hex W/Wsh 3/8-16 Unc	71	169183	Strap Torque Lh Hydro
20	150280	Bolt, Hex 7/16-20 x 4-1/4	73	169182	Strap Torque Rh Hydro
21	140845	Knob Deluxe	74	169496	Spacer, Axle
22	169498	Rod, Brake Hydro	75	121749X	Washer 25/32 x 1-1/4 x 16 Ga.
23	171258	Bracket Asm. Anti-Rot EVX	76	12000001	E-Ring
24	73350600	Locknut	77	123583X	Key, Square
25	106888X	Spring, Brake Rod	78	121748X	Washer 25/32 x 1-5/8 x 16 Ga.
26	19131316	Washer	81	165596	Shaft Asm. Cross Hydro
27	76020412	Pin Cotter 1/8 x 3/4 CAD.	82	123782X	Spring Torsion T/A
28	145204	Rod, Parking Brake	83	19171216	Washer 17/32 x 3/4 x 16 Ga.
29	71673	Cap, Parking Brake	84	169594	Link Transaxle
30	169592	Bracket, Transaxle	89	164892X428	Console, Shift
32	74760512	Bolt Hex Hd 5/16-18 Unc x 3/4	95	170201	Control Asm. Bypass Hydro
33	72140506	Bolt Carriage 5/16-18 UNC x 3/4	96	4497H	Retainer Spring 1" Zinc/Cad
34	155071	Shaft, Foot Pedal	144	19111016	Washer 11/32 x 5/8 x 16 Ga.
35	120183X	Bearing, Nylon	150	165850	Bushing Bellcrank Grd Drive
36	19211616	Washer	151	19133210	Washer 13/32 x 2 x 10 Ga.
37	1572H	Pin, Roll	156	166002	Washer Srrted 5/16ID x 1.125
38	131494	Pulley, Idler, Flat	158	165589	Bracket Shift Mount
39	<b>74760644</b>	Bolt	159	<b>165494</b>	Hub Tapered Flange Shift Lt
40	4470J	Spacer Split	161	72140406	Bolt Rdhd Sqnk 1/4-20 x 3/4 Gr. 5
41	165838	Keeper, Belt Idler Fool-Proof	162	73680400	Nut Crownlock 1/4-20 Unc
42	19131312	Washer 13/32 x 13/16 x 12 Gauge	163	74780416	Bolt Hex Fin 1/4-20 Unc x 1 Gr. 5
47	<b>127783</b>	Pulley, Idler, V-Groove	164	19091010	Washer 5/8 x .281 x 10 Ga
48	154407	Bellcrank Clutch Grnd Drv Stl	165	165623	Bracket Pivot Lever
49	123205X	Retainer, Belt	166	166880	Screw 5/16-18 x 5/8
50	74760624	Bolt	168	165492	Bolt Shoulder 5/16-18 x .561
51	73680600	Nut	169	165580	Plate Fastening Lt
52	73680500	Nut Crown Lock 5/16-18	197	169613	Nyliner Snap-In 5/8" ID
53	105710X	Link, Clutch	198	169593	Washer Nyliner 7/8 ID x .105
55	105709X	Spring, Return, Clutch	199	169612	Bolt Shoulder 5/16-18 Unc
56	74760620	Bolt	200	72140508	Bolt Rdhd Sqnk 5/16-18 UNC x 1
57	140294	V-Belt, Ground Drive	202	72110612	Bolt Carr Sh 3/8-16 x 1-1/2 Gr.5

**NOTE:** All component dimensions give in U.S. inches.  
1 inch = 25.4 mm

## TRACTOR - MODEL NUMBER QP20H46B

### STEERING ASSEMBLY

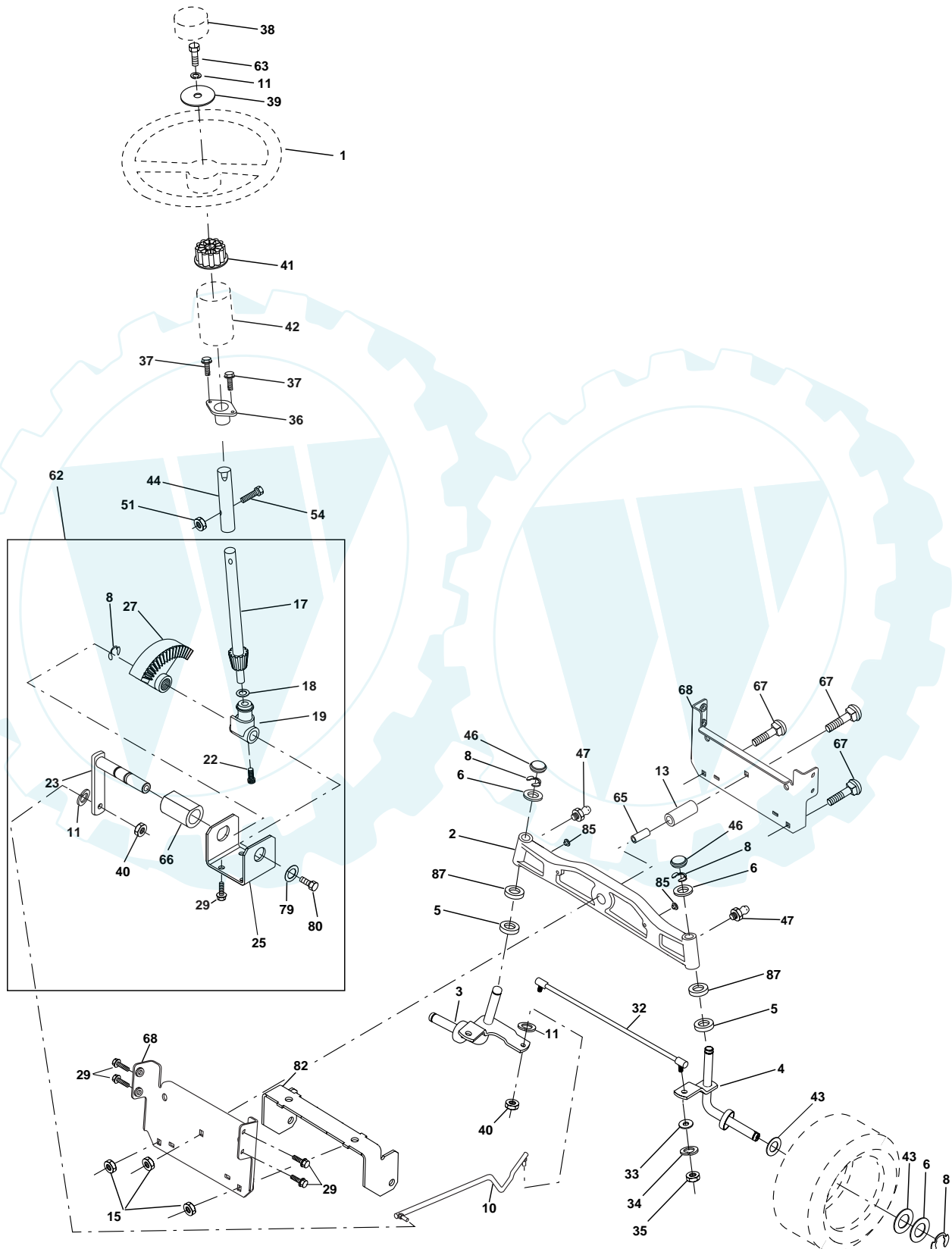



## TRACTOR - MODEL NUMBER QP20H46B

### STEERING ASSEMBLY

KEY NO.	PART NO.	DESCRIPTION
1	159944X428	Wheel Steering
2	165854	Axle Cast Lt Machined
3	169840	Spindle Asm LH
4	169839	Spindle Asm RH
5	6266H	Bearing Race Thrust Harden
6	121748X	Washer 25/32 X 1-5/8 X 16 Ga
8	12000029	Ring Klip #t5304-75
10	169832	Link Drag
11	10040600	Washer Lock Hvy Hlcl Spr 3/8
13	136518	Spacer Brg Axle Front
15	145212	Nut Hex Flange Lock
17	156546	Shaft Asm Strg Private Label
18	57079	Washer Thrust 515x 750x 033
19	160395	Support Shaft
22	165857	Screw Hex Wsh Hd Torx
23	165851	Shaft Asm Pittman
25	154406	Bracket Steering
27	136874	Gear Sector 22 Teeth
29	17060612	Screw 3/8-16x3/4
32	171888	Rod Tie
33	19111216	Washer 11/32 x 3/4 x 16 Ga.
34	10040500	Washer Lock Hry Hlcl Spr 5/16
35	73540500	Nut Crownlock 5/16 - 24 UNF
36	155099	Bushing Strg
37	152927	Screw TT #32.5 x 5 x 3/8 Flange
38	159946X428	Cap Wheel Steer
39	19132411	Washer 13/32 x 1-1/20 x 11 Ga
40	7810H	Nut Lock Center 3/8-24 Unf
41	159945	Adaptor Wheel Strg
42	145054X428	Boot Dash Steering
43	121749X	Washer 25/32 X 1 1/4 X 16 Ga
44	153720	Extension Steering Non-adjust
46	121232X	Cap Spindle Fr Top Blk
47	6855M	Fitting Grease
51	73800500	Nut Lock Hex W/Ins 5/16-18 UNC
54	74780520	Bolt Fin Hex 5/16-18 UNC x 1-1/4
62	167902	Steering Assembly
63	74780616	Bolt Fin Hex 3/8-16 UNC x 1 Gr. 5
65	160367	Spacer Brace Axle
66	154404	Bearing Arm Pittm-an
67	72140618	Bolt Rdhd Sqn 3/8-16 x 2-1/4
68	169827	Brace, Axle
79	19132012	Washer 13/32 x 1-1/4 x 12 Ga.
80	74950612	Bolt Hex Nylon 3/8-16 x 3/4
82	169835	Bracket Susp Chassis Front
85	133835	Fastner Christmas Tree
87	<b>173966</b>	Washer Flat .781 x 1-1/2 x .14

**NOTE:** All component dimensions given in U.S. inches.  
1 inch = 25.4 mm.

## TRACTOR - MODEL NUMBER QP20H46B

### ENGINE

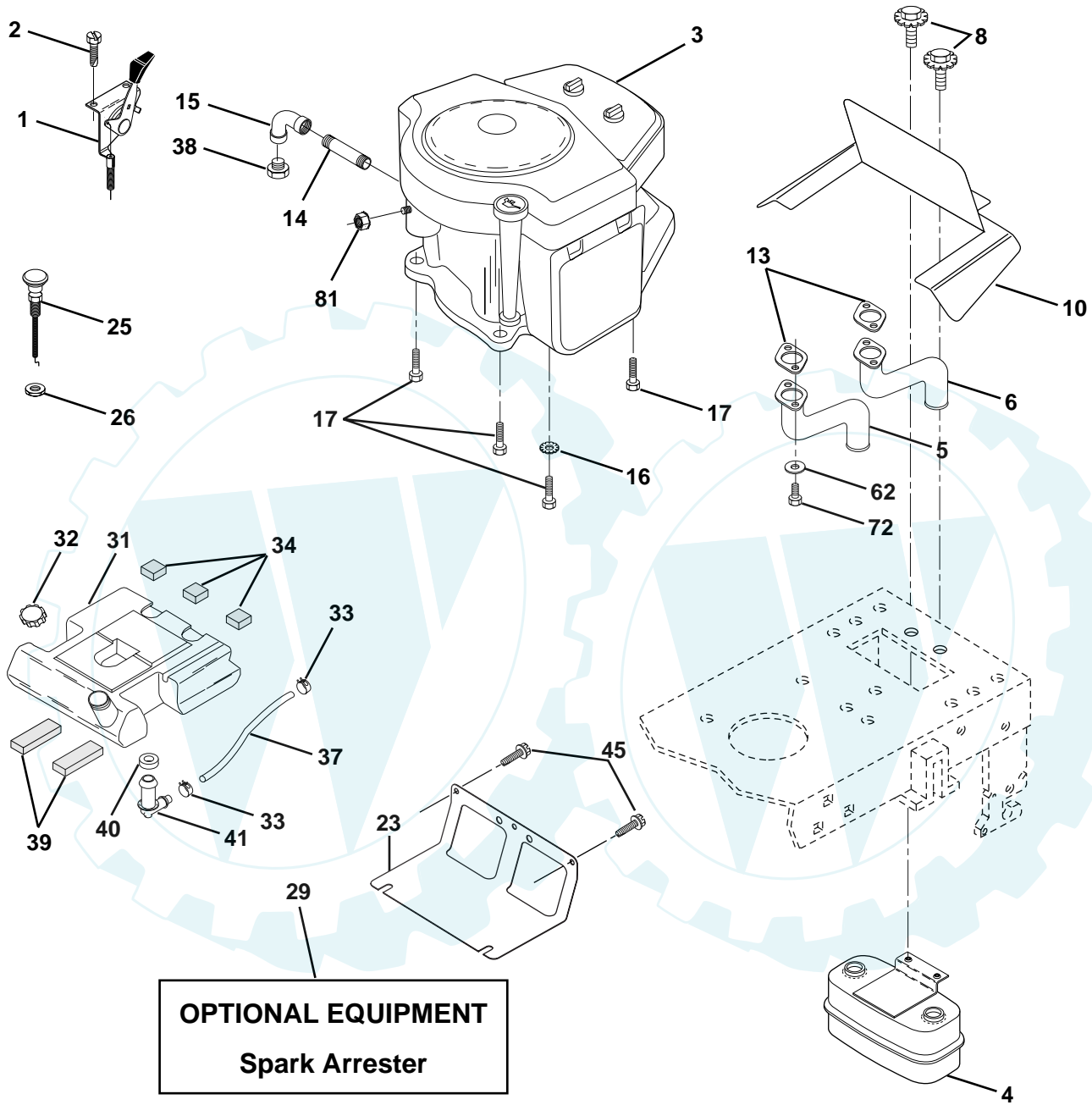

## TRACTOR - MODEL NUMBER QP20H46B

### ENGINE

KEY NO.	PART NO.	DESCRIPTION
1	148875	Control Th/Flag180 LH 36"
2	17720410	Screw Hex Thd Cut 1/4-20x5/8 T
3	-----	Engine, Briggs Model 407777 (Order parts from engine manufacturer)
4	149723	Muffler Asm Twin Lo-Tone
5	159955	Pipe Exhaust LH Intek
6	160589	Pipe Exhaust RH Intek
8	150176	Bolt 5/16-18 UNC x 3/4 w/Sems
10	162797	Shield Browning Intek II
13	165391	Muffler Gasket
14	13280336	Nipple Pipe 3/8 Npt X 4-1/2"
15	13200300	Elbow Std 90 Degree 3/8-18 Npt
16	11050600	Washer Lock Ext Tooth 3/8
17	17490624	Screw Thdrol 3/8-16 x 1-1/2
23	169837	Shield Heat
25	145996	Choke Control 37"
26	73920600	Nut, Keps 3/8-24 UNF
29	137180	Kit Spark Arrestor (Flat Scrn)
31	151346	Tank Fuel 3 50 Rear YTGT
32	140527	Cap Asm Fuel W/sym Vented
33	123487X	Clamp Hose Black
34	106082X	Pad, Spacer
37	8543R	Line Fuel
38	-----	Plug Oil Drain (Order From EngineManufacturer)
39	109227X	Pad, Idler
40	3645J	Bushing
41	139277	Stem Tank Fuel
45	17000612	Screw Hexwsh Thdr 3/8-16 x 3/4
62	10040500	Washer Lock 5/16
72	71070512	Screw Hex Hd Cap 5/16-18 x 3/4
81	73510400	Nut Keps Hex 1/4-20 UNC

**NOTE:** All component dimensions given in U.S. inches  
1 inch = 25.4 mm

## TRACTOR - MODEL NUMBER QP20H46B

### SEAT ASSEMBLY

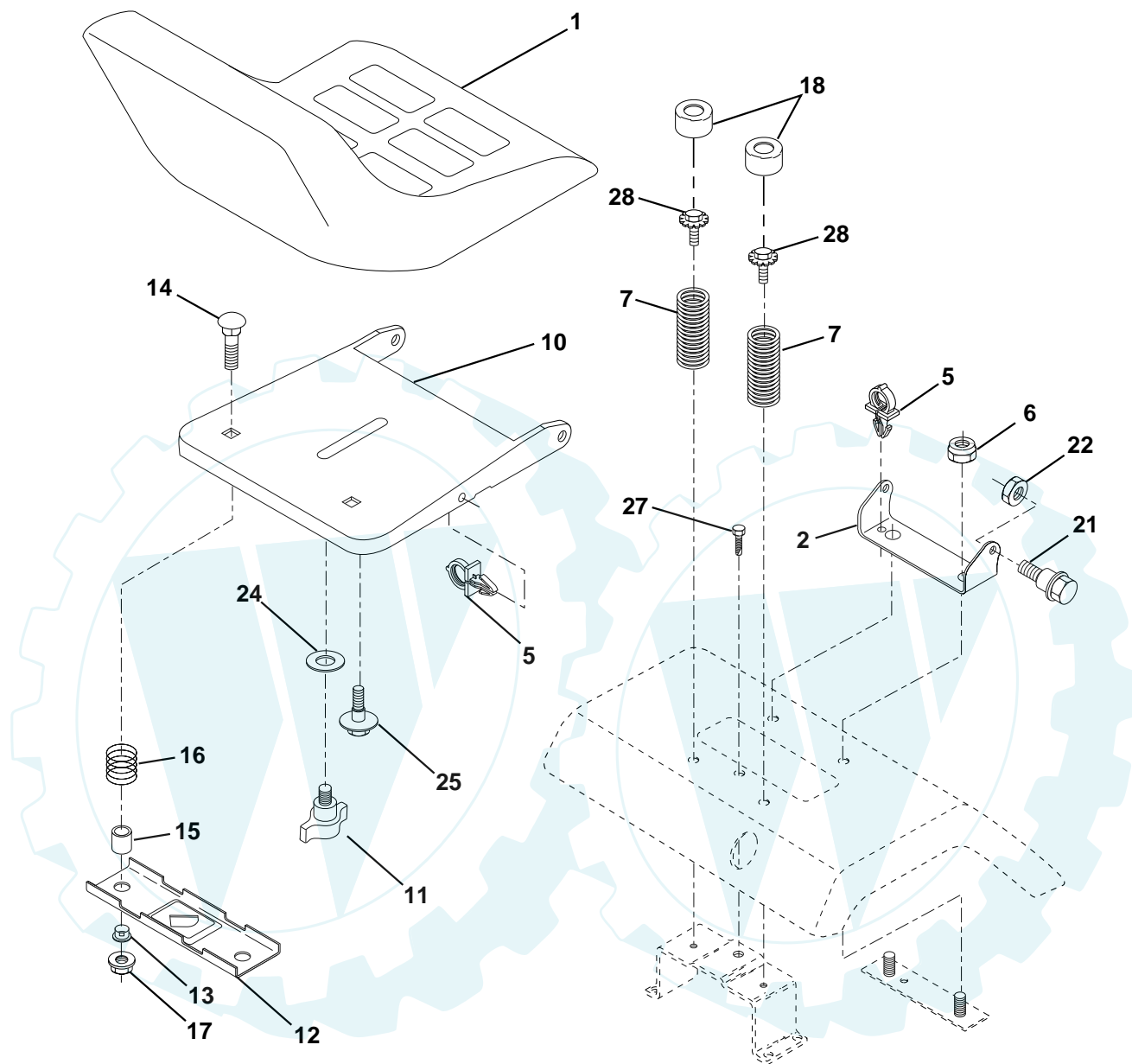

KEY NO.	PART NO.	DESCRIPTION
1	140118	Seat
2	140551	Bracket Pivot Seat 8 720
5	145006	Clip Push-In
6	73800600	Nut Hex w/Ins. 3/8-16 Unc
7	124181X	Spring Seat Cprsn 2 250 Blk Zi
10	155925	Pan Seat
11	166369	Knob Seat Adj. Wingnut
12	121246X	Bracket Mounting Switch
13	121248X	Bushing Snap Blk Nyl 50 Id
14	72050412	Bolt Rdhd Sqnk 1/4-20x1-1/2
15	121249X	Spacer Split 28x 88

KEY NO.	PART NO.	DESCRIPTION
16	123740X	Spring Cprsn
17	123976X	Nut Lock 1/4 Lge Flg Gr 5 Zinc
18	124238X	Cap Spring Seat
21	171852	Bolt Shoulder 5/16-18 Unc
22	73800500	Nut Hex Lock W/Ins 5/16-18
24	19171912	Washer 17/32 X 1-3/16 X 12 Ga.
25	127018X	Bolt Shoulder 5/16-18 X 62
27	17490608	Screw Thdrol 3/8-16 x 1/2
28	171877	Bolt 5/16-18 Unc x 3/4 w/Sems

**NOTE:** All component dimensions given in U.S. inches.  
1 inch = 25.4 mm

## TRACTOR - MODEL NUMBER QP20H46B

### DECALS

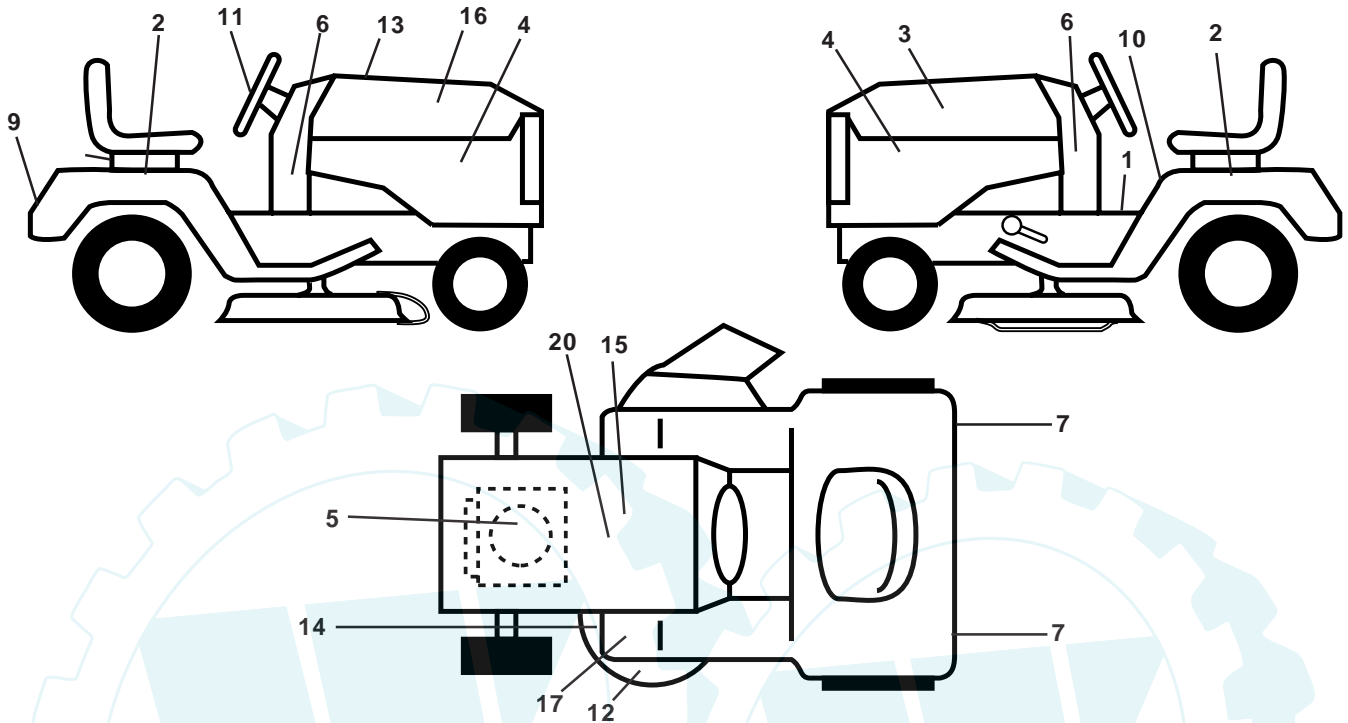

KEY NO.	PART NO.	DESCRIPTION
1	156868	Decal Oper
2	172670	Decal Fender Auto
3	172599	Decal Hood LH
4	172597	Decal Side Panel
5	172975	Decal HP Engine
6	172593	Decal Dash
7	106202X	Reflector Tail Light
9	172596	Decal Fender Logo
10	157002	Decal Fender Danger E
11	172595	Decal Ins Strg Whl
12	168548	Decal Deck Mulch/Vented

KEY NO.	PART NO.	DESCRIPTION
13	172933	Decal Replacement Hood
14	160397	Decal V-Belt Schematic
15	168427	Decal Battery Power Pro
16	172598	Decal Hood Rh
17	4900J	Decal Clutch/Bake
20	145005	Decal Bat Dan/Psn
--	169210	Decal By Pass Lt Hydro
--	133671	Pad Footrest
--	138311	Decal Handle Lft Height Adjust
--	174763	Manual Owner's (English)

### WHEELS & TIRES

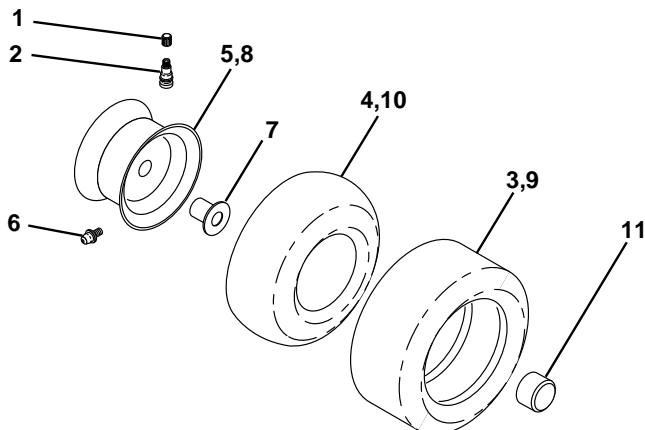

KEY NO.	PART NO.	DESCRIPTION
1	59192	Cap Valve Tire
2	65139	Stem Valve
3	106222X	Tire F Ts 15 X 6 0 - 6 Service
4	59904	Tube Front (Service Item Only)
5	106732X421	Rim Asm 6"front Service
6	278H	Fitting Grease (Front Wheel Only)
7	9040H	Bearing Flange (Front Wheel Only)
8	106108X421	Rim Asm 8"rear Service
9	122082X	Tire R Ts 20x10 -8 C Service
10	7152J	Tube Rear (Service Item Only)
11	104757X	Cap Axle Blk 1 50 X 1 00
--	144334	Sealant, Tire ( 10 oz. Tube)

**NOTE:** All component dimensions given in U.S. inches  
1 inch = 25.4 mm

# REPAIR PARTS

[www.ersatzteil-service.de](http://www.ersatzteil-service.de)

## TRACTOR - MODEL NUMBER QP20H46B

### MOWER DECK

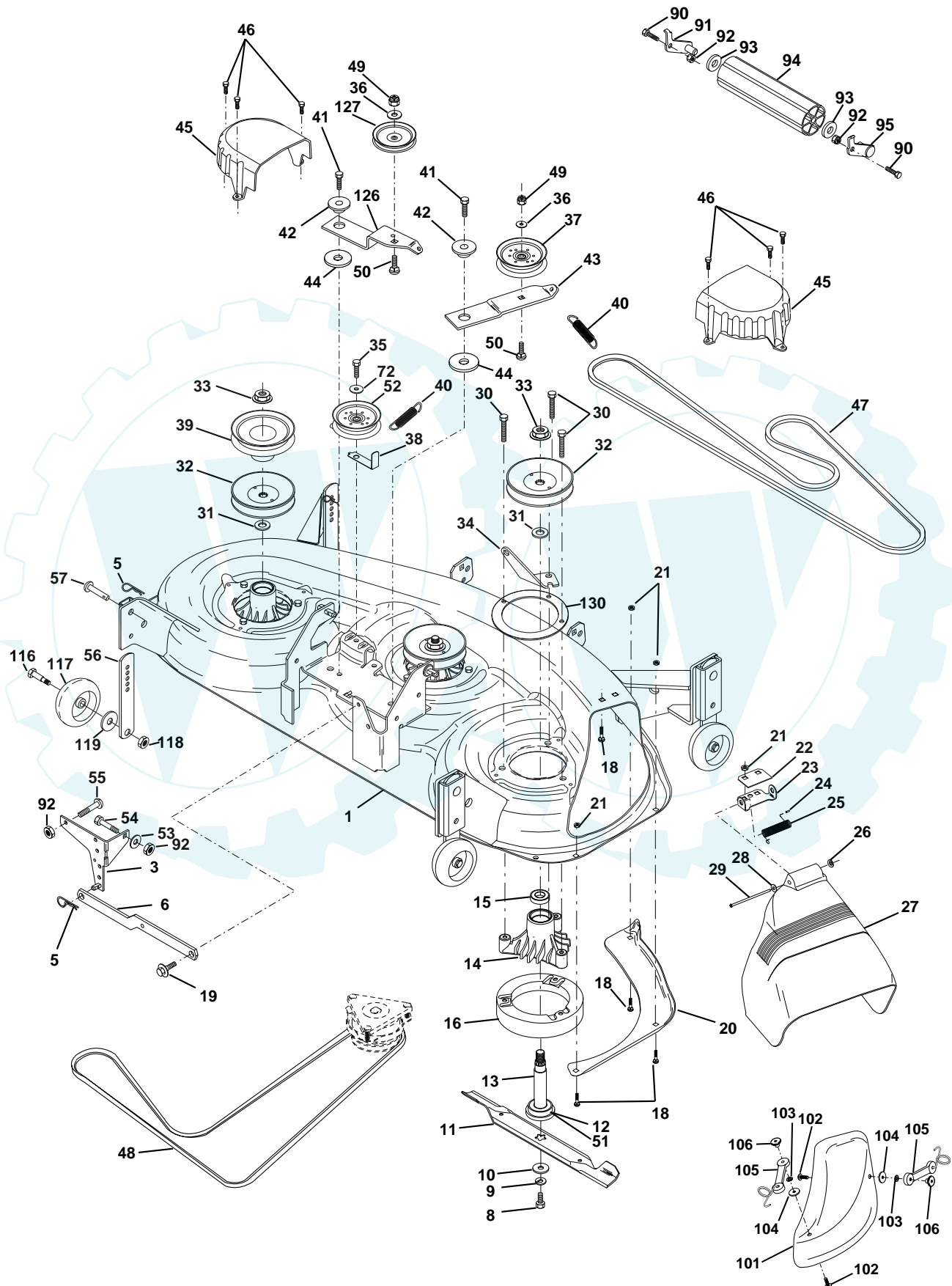

## TRACTOR - MODEL NUMBER QP20H46B

### MOWER DECK

KEY NO.	PART NO.	DESCRIPTION	KEY NO.	PART NO.	DESCRIPTION
1	164811	Deck Asm., Mower 46"	43	144949	Arm, Idler Secondary
3	138457	Bracket Asm., Sway Bar	44	133943	Washer, Hardened
5	4939M	Retainer Spring	45	145059	Cover, Mandrel Deck
6	130832	Arm, Suspension, Rear (Sway Bar)	46	137729	Screw, Thdroll. 1/4-20 x 5/8
8	850857	Bolt, Patched 3/8-24 x 1-1/4 Gr. 8	47	144959	V-Belt, Mower, Secondary
9	10030600	Washer, Lock Hvy., Unplated 3/8	48	148763	V-Belt, Mower, Primary
10	140296	Washer, Hard Blade, Mower Vented	49	73680600	Nut, Crownlock 3/8-16 UNC
11	170698	Blade, 46" Hi Perf	50	72110612	Bolt, Carriage 3/8-16 x 1-1/2 Gr. 5
--	152443	Blade, 46" Mulching	51	153390	Washer, Felt
12	129895	Bearing, Ball, Mandrel #6204	52	156493	Pulley Idler 46 Pri. Drive
13	137553	Shaft Asm. w/Lower Bearing (Includes Key No. 12)	56	155986	Bar Adjusting Gage wheel
14	137152	Housing, Mandrel	57	156941	Pin Head Rivet
15	110485X	Bearing, Ball, Mandrel	72	19131616	Washer 13/32 x 1 x 16 Ga.
16	140329	Stripper, Mower Round	90	74760616	Bolt, Fin, Hex 3/8-16 UNC x 1
18	72140505	Bolt, Carriage 5/16-18 x 5/8	91	132274	Bracket, Asm Noseroller, LH
19	132827	Bolt, Hex Head, Shoulder 5/16-18	92	73800600	Nut, Lock, Hex w/Ins 3/8-16UNC
20	145055	Baffle, Vortex Mower 46"	93	19171416	Washer 17/32 x 7/8 x 16 Ga.
21	73680500	Nut, Crownlock 5/16-18 UNC	94	132264	Roller, Nose 38 & 42
22	134753	Stiffener, Bracket	95	132273	Bracket, asm Noseroller RH
23	131267	Bracket, Deflector	101	145579	Cover Mulcher 46" Black
24	105304X	Cap, Sleeve	102	71161010	Screw Phillips Truss Head
25	149287	Spring, Torsion, Deflector	103	10071000	Washer Lock #10
26	110452X	Nut, Push	104	19061216	Washer #10
27	166883X428	Shield, Deflector Mower	105	160793	Latch Asm mulch/Bagger
28	19111016	Washer 11/32 x 5/8 x 16 Ga.	106	2029J	Nut Weld
29	131491	Rod, Hinge	116	137644	Bolt, Shoulder
30	157722	Screw, WshHead, Thdroll	117	133957	Gauge Wheel
31	129963	Washer, Spacer Mower Vented	118	73930600	Nut, Centerlock 3/8-16 UNC
32	153531	Pulley, Mandrel	119	19121414	Washer 3/8 x 7/8 x 14 Ga.
33	137266	Nut, Flg. Top Lock Cntr. 9/16	126	144948	Arm, Idler, Primary Deck 46"
34	144945	Anchor, Spring Deck 46"	127	146763	Pulley, Idler, V-Groove Dim. 4.25
35	17490628	Screw, Thdroll 3/8-16 x 1-3/4 Tytt	--	143651	Mandrel Assembly ( Includes Key Nos. 8-10, 12-15, 31 and 33)
36	19131316	Washer 13/32 x 13/16 x 16 Ga.	--	158314	Mower Serv 46" (Standard Deck Order nose roller, guage wheels, and mulch plate separately Key Nos. 90- 95,101-106, and 116-118)
37	131494	Pulley, Idler, Flat			
38	156086	Keeper, Belt, Idler			
39	144917	Pulley, Idler, Driven			
40	137273	Spring, Secondary 44/46/50 Vent			
41	17060620	Screw 3/8-16 x 1-1/4			
42	165723	Spacer, Retainer			

**NOTE:** All component dimensions given in U.S. inches  
1 inch = 25.4 mm

# REPAIR PARTS

[www.ersatzteil-service.de](http://www.ersatzteil-service.de)

## TRACTOR - MODEL NUMBER QP20H46B

### MOWER LIFT

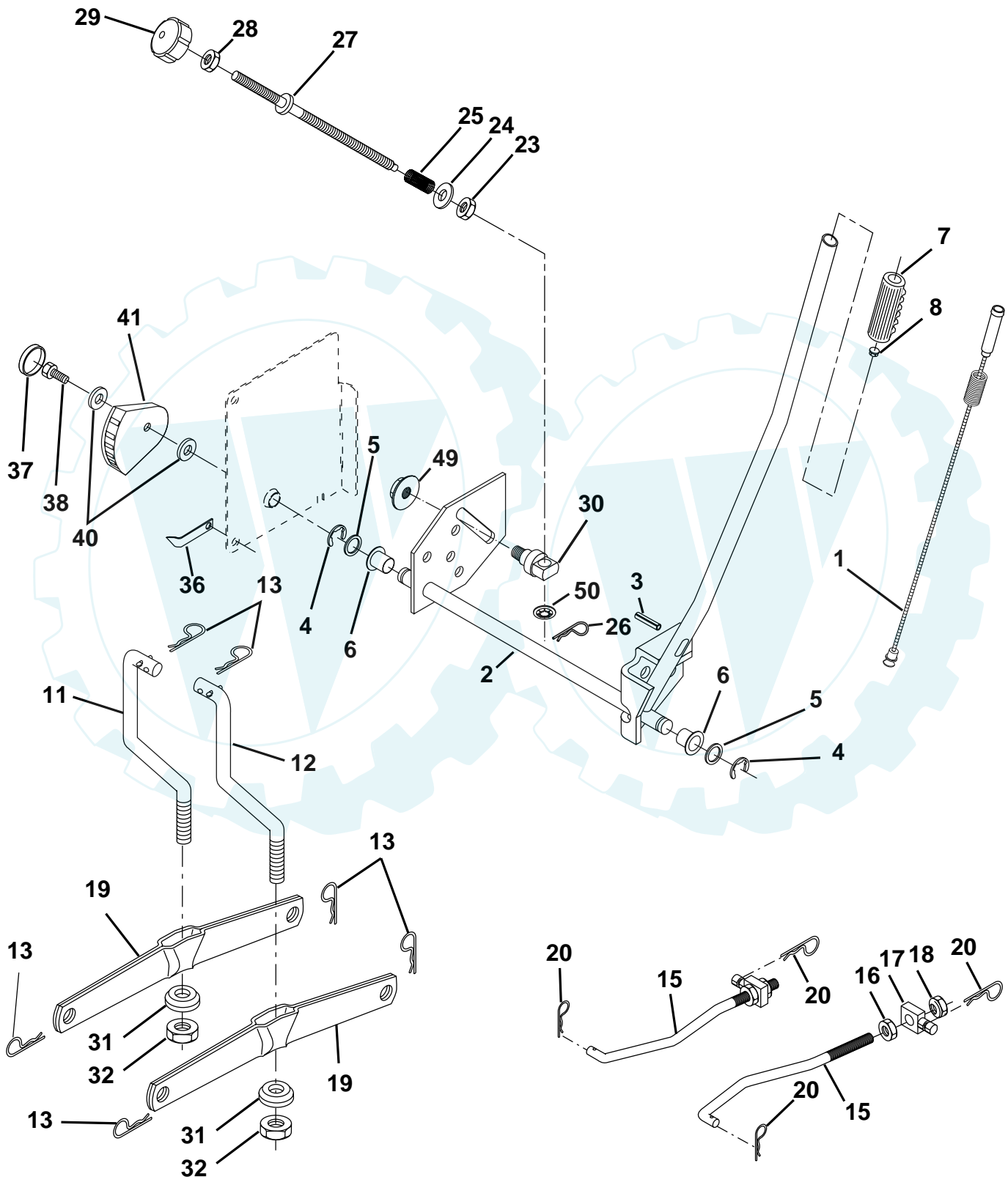



## TRACTOR - MODEL NUMBER QP20H46B

### MOWER LIFT

KEY NO.	PART NO.	DESCRIPTION
1	159460	Wire Asm Inner/Sprg W/plunger LT
2	159471	Shaft Asm Lift RH w/Inf
3	105767X	Pin Groove 1 500 Zinc
4	12000002	E Ring #5133-62
5	19211621	Washer 21/32 X 1 X 21 Ga
6	120183X	Bearing Nylon Blk 629 Id
7	125631X	Grip Handle
8	124526X	Button Plunger Black
11	139865	Link Lift LH Fixed Length
12	139866	Link Lift RH Fixed Length
13	4939M	Retainer Spring
15	<b>173288</b>	Link Front
16	73350800	Nut Jam Hex 1/2-13 Unc
17	130171	Trunnion Blk Zinc
18	73800800	Nut Lock w/Wsh 1/2-13unc
19	139868	Arm Suspension Rear
20	163552	Retainer Spring
23	110807X	Nut Special
24	19131016	Washer 13/32 X 5/8 X 16 Ga
25	2876H	Spring 2-1/8"
26	169484	Retainer Clip
27	126971X	Rod Adj Lift Zinc 7.49 Wrk Lg
28	73350600	Nut Hex Jam 3/8-16 Unc
29	138057	Knob Inf 3/8-16 Unc Blk W/sym
30	150233	Trunnion Infin Height
31	<b>169865</b>	Bearing Pvt Lift
32	73540600	Nut Crownlock 3/8 - 24
36	155097	Pointer Height Indicator
37	123935X	Plug Hole Blk 1.485/1.515 Dia.
38	17060516	Screw 5/16-18 x 1
40	19112410	Washer 11/32 x 1-1/2 10 Ga.
41	155098	Indicator Height STLT
49	145212	Nut Hex Flange Lock
50	110452X	Nut PUSh Phos & Oil

**NOTE:** All component dimensions given in U.S. inches  
1 inch = 25.4 mm