

**TRACTOR - - MODEL NUMBER FD20H25TA PRODUCT NO. 954 56 95-09**  
**SCHEMATIC**

www.ersatzteil-service.de

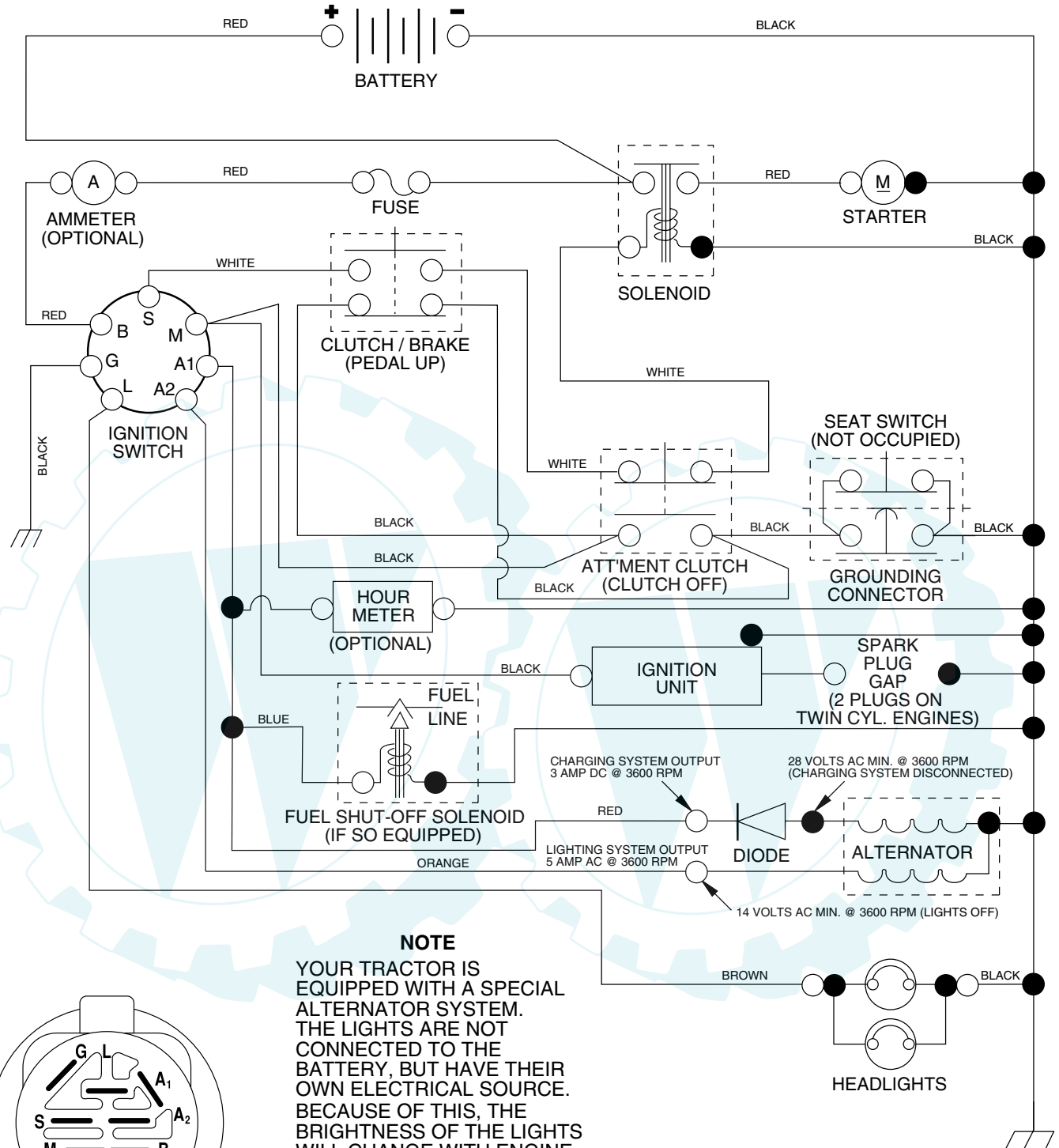

**NOTE**

YOUR TRACTOR IS EQUIPPED WITH A SPECIAL ALTERNATOR SYSTEM. THE LIGHTS ARE NOT CONNECTED TO THE BATTERY, BUT HAVE THEIR OWN ELECTRICAL SOURCE. BECAUSE OF THIS, THE BRIGHTNESS OF THE LIGHTS WILL CHANGE WITH ENGINE SPEED. AT IDLE THE LIGHTS WILL DIM. AS THE ENGINE IS SPEEDED UP, THE LIGHTS WILL BECOME THEIR BRIGHTEST.

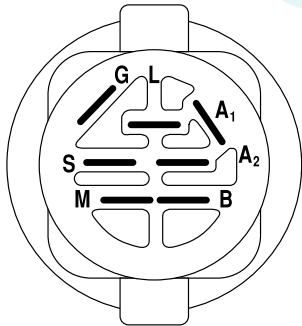

**IGNITION SWITCH**

POSITION	CIRCUIT	"MAKE"
OFF	M+G+A1	NONE
RUN/LIGHT	B+A1	A2+L
RUN	B+A1	NONE
START	B + S + A1	NONE

**WIRING INSULATED CLIPS**

**NOTE:** IF WIRING INSULATED CLIPS WERE REMOVED FOR SERVICING OF UNIT, THEY SHOULD BE REPLACED TO PROPERLY SECURE YOUR WIRING.

●  
NON-REMOVABLE CONNECTIONS

○  
REMOVABLE CONNECTIONS

TRACTOR -- MODEL NUMBER PD20H42STA PRODUCT NO. 954 56 95-09  
ELECTRICAL

[www.ersatzteil-service.de](http://www.ersatzteil-service.de)

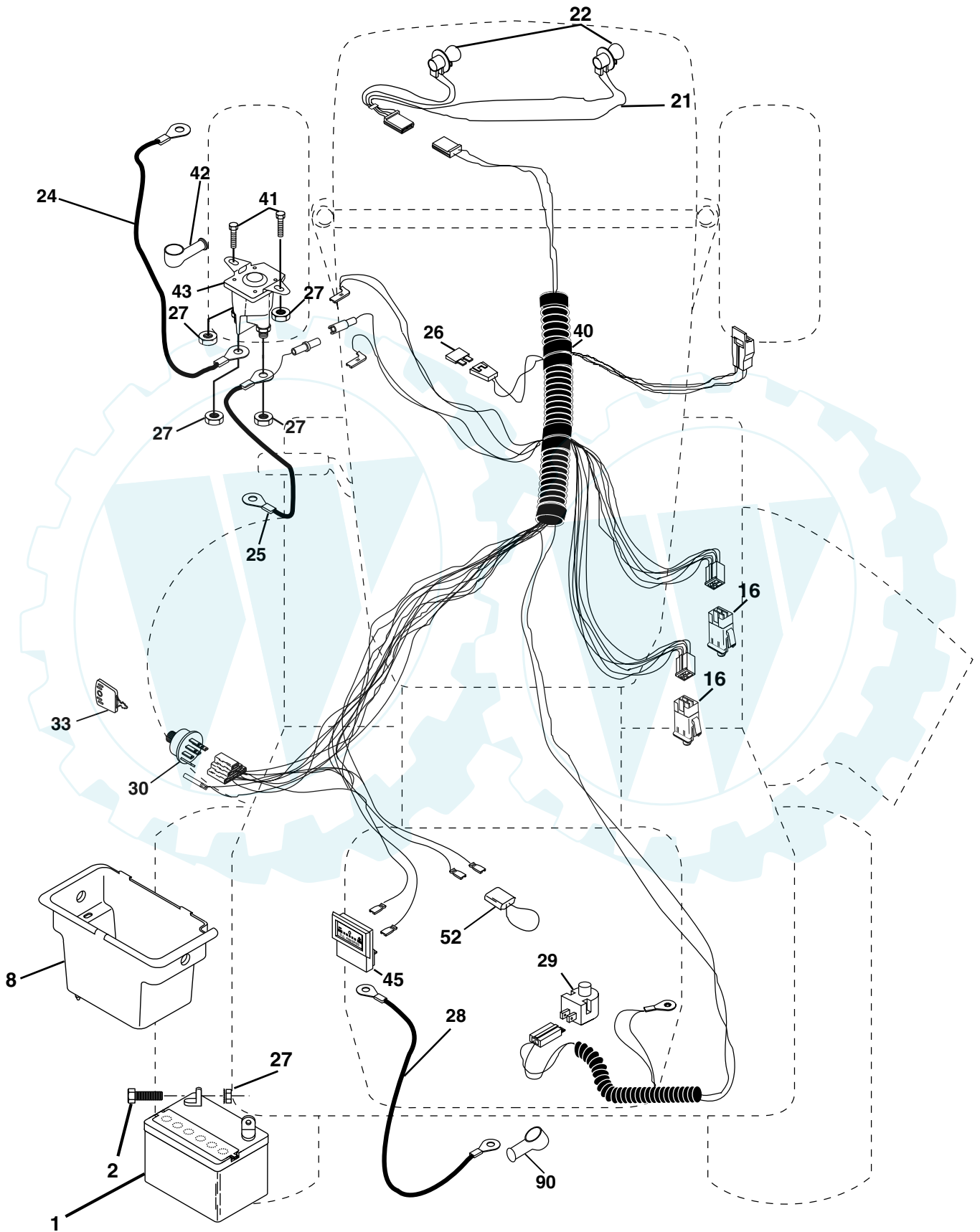

**TRACTOR - - MODEL NUMBER TD20H2S1A PRODUCT NO. 954 56 95-09  
ELECTRICAL**

<b>KEY NO.</b>	<b>PART NO.</b>	<b>DESCRIPTION</b>
1	144927	Battery
2	74760412	Bolt Hex Hd 1/4-20unc X 3/4
8	176689	Box Battery Fender
16	176138	Switch Interlock
21	183759	Harness Socket Light
22	4152J	Bulb, Light # 1156
24	4799J	Cable Battery
25	146147	Cable Battery 6 Ga Red w/16 wire
26	175158	Fuse
27	73510400	Nut Keps Hex 1/4-20 Unc
28	4207J	Cable Ground 6ga 12 black
29	121305X	Switch Plunger Nc Gray
30	175566	Switch Ign
33	140401	Key Ign Molded Generic
40	179720	Harness Ign
41	71110408	Bolt Fin Hex 1/4-20uncx 1/2
42	131563	Cover Terminal Red
43	178861	Solenoid
45	121433X	Ammeter Rectangular
52	141940	Protection Loop
90	180449	Cover Terminal Battery

**NOTE:** All component dimensions given in U.S. inches  
1 inch = 25.4 mm

TRACTOR - - MODEL NUMBER PD20H42STA PRODUCT NO. 954 56 95-09  
CHASSIS

[www.ersatzteil-service.de](http://www.ersatzteil-service.de)

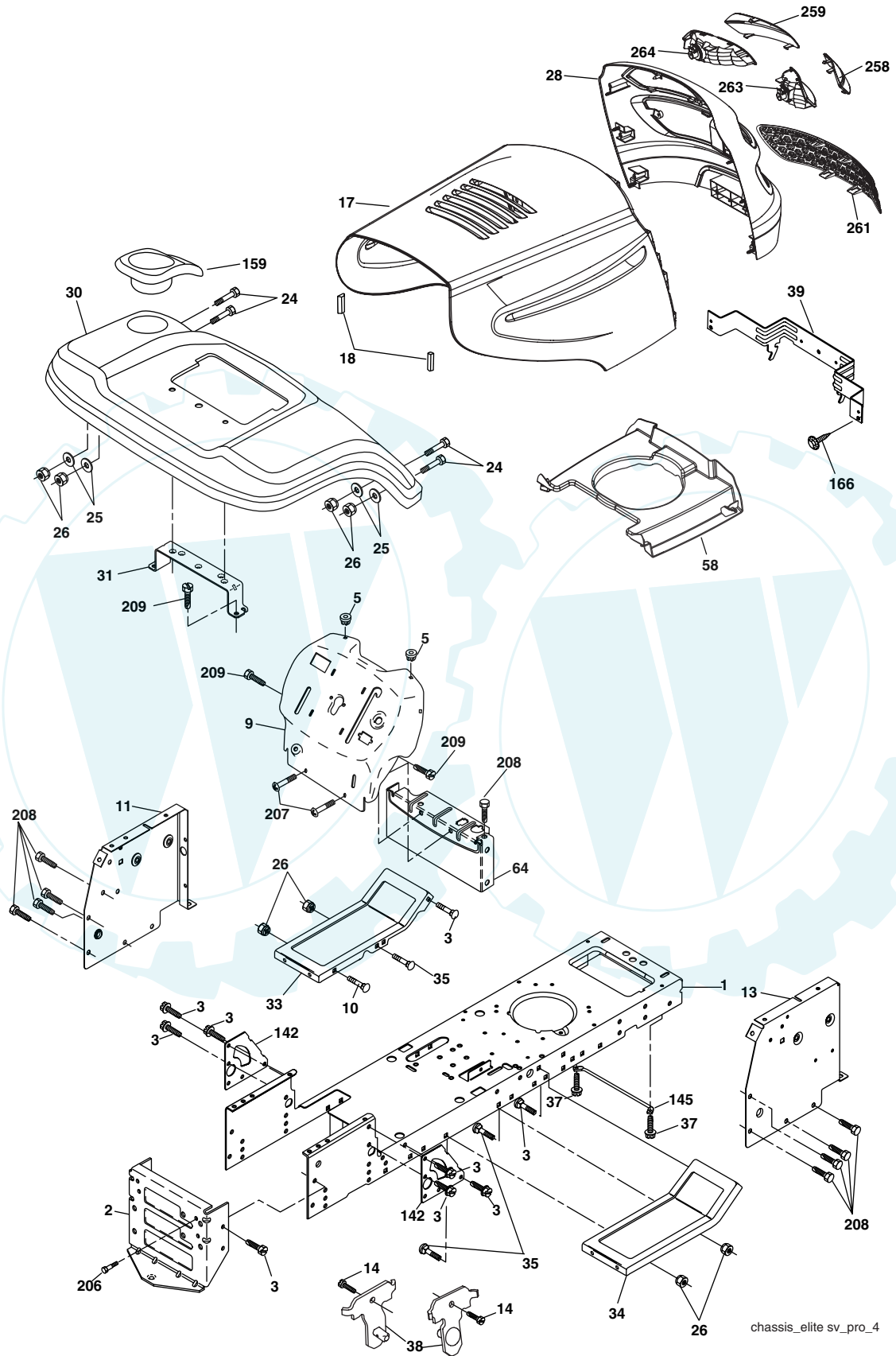

chassis\_elite sv\_pro\_4

**TRACTOR - - MODEL NUMBER PD20H425TA PRODUCT NO. 954 56 95-09  
CHASSIS**

KEY NO.	PART NO.	DESCRIPTION
1	174619	Chassis
2	176554	Drawbar
3	17060612	Screw 3/8-16 X .75
5	155272	Bumper Hood/Dash
9	168337X012	Dash P/L
10	72140608	Bolt Carriage 3/8-16 x 1
11	174996	Panel Dash Lh
13	175255	Panel Dash Rh
14	17490608	Screw Thdrol 3/8-16 x 1/2
17	183393X428	Hood
18	184921	Bumper Hood
23	124028X	Bushing
24	74780616	Bolt Fin Hex 3/8-16 x 1 Gr 5
25	19131312	Washer 13/32 X 13/16 X 12 Ga
26	73800600	Nut Lock Hex W/Ins 3/8-16 Unc
28	183828	Grille/Lens Asm
30	169470X428	Fender Footrest STLT Pnt
31	136619	Bracket Fender
33	179716X428	Footrest Pnt Lh
34	179717X428	Footrest Pnt Rh
35	72110606	Bolt Rdhd Sht Sqnk 3/8-16 x 3/4
37	17490508	Screw Thdrol 6/16-18 x 1/2 TYT
38	175710	Bracket Asm Pivot Mower Rear
39	174714	Bracket Pivot
58	<b>185949</b>	Duct Air
64	154798	Dash Lower STLT
142	175702	Plate Reinforcement STLT
145	156524	Rod Pivot Chassis/Hood
159	169473X428	Cupholder
166	171875	Screw Hwhd Hi-Lo #13-16 x 3/4
206	170165	Bolt Shoulder 5/16-18
207	17670508	Screw Thdrol 5/16-18 x 1/2
208	17670608	Screw Thdrol 3/8-16 x 1/2
209	17000612	Screw Hexwsh Thdr 3/8-16 x 3/4
258	183835X599	Lens Grille Pro RH
259	183834X599	Lens Grille Pro LH
261	183829Z428	Insert Grille
263	183832	Bezel Grille LH
264	183833	Bezel Grille RH

**NOTE:** All component dimensions given in U.S. inches  
1 inch = 25.4 mm

TRACTOR -- MODEL NUMBER PD20H42STA PRODUCT NO. 954 56 95-09  
DRIVE

[www.ersatzteil-service.de](http://www.ersatzteil-service.de)

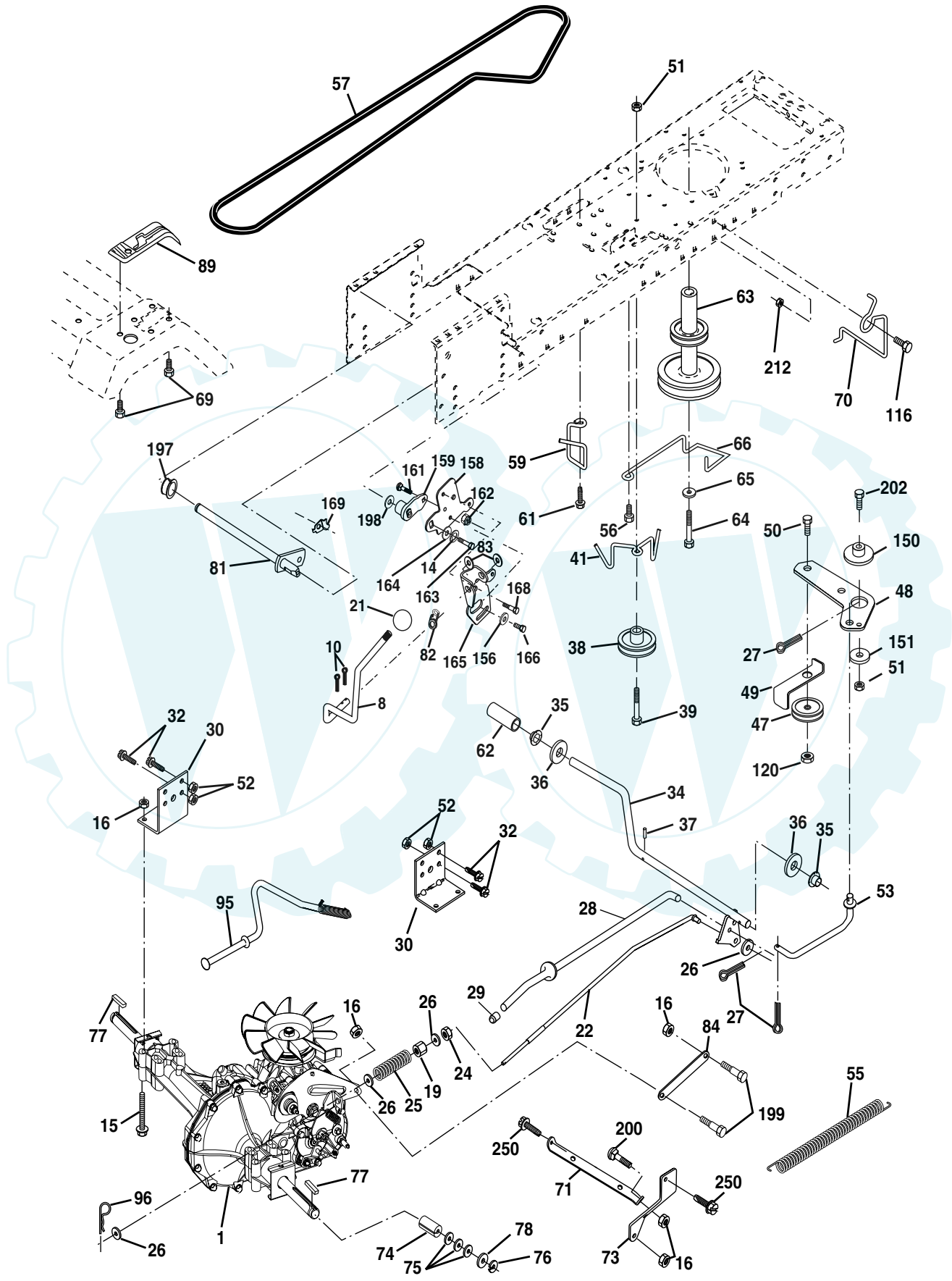



**TRACTOR - - MODEL NUMBER FD20H2STA PRODUCT NO. 954 56 95-09  
DRIVE**

KEY NO.	PART NO.	DESCRIPTION	KEY NO.	PART NO.	DESCRIPTION
1	-----	Transaxle Hydro Gear 314-0510 (Order Parts From Transaxle Manufacturer)	66	154778	Keeper Belt Engine
8	165619	Rod Shift Hydro LT	69	142432	Screw
10	76020416	Pin Cotter 1/8 x 1 CAD	70	134683	Guide Belt
14	10040400	Washer Lock Hvy Helical	71	169183	Strap Torque Lh Hydro
15	74490544	Bolt, Hex FLGHD 5/16-18 Gr. 5	73	169182	Strap Torque Rh Hydro
16	73800500	Nut Lock Hex W/Ins 5/16-18 Unc P	74	137057	Spacer, Axle
19	73800600	Nut Lock Hex W/Wsh 3/8-16 Unc	75	121749X	Washer 25/32 x 1-1/4 x 16 Gauge
21	140845	Knob, Round 1/2-13	76	12000001	E-Ring
22	169498	Rod, Brake Hydro	77	123583X	Key, Square
24	73350600	Nut	78	121748X	Washer 25/32 x 1-5/8 x 16 Gauge
25	106888X	Spring, Brake Rod	81	165596	Shaft Asm. Cross Hydro
26	19131316	Washer	82	123782X	Spring Torsion T/A
27	76020412	Pin Cotter 1/8 x 3/4 CAD.	83	19171216	Washer 17/32 x 3/4 x 16 Ga.
28	175765	Rod, Parking Brake	84	169594	Link Transaxle
29	71673	Cap, Parking Brake	89	169373X428	Console, Hydro
30	169592	Bracket, Transaxle	95	170201	Control Asm Bypass Hydro
32	74760512	Bolt Hex Hd 5/16-18 Unc x 3/4	96	4497H	Retainer Spring 1" Zinc/Cad
34	175578	Shaft, Foot Pedal	116	72140608	Bolt RDHD SQNK 3/8-16 UNC x 1
35	120183X	Bearing, Nylon	120	73900600	Nut Lock Flg 3/8-16 Unc
36	19211616	Washer	150	175456	Spacer Retainer
37	1572H	Pin, Roll	151	19133210	Washer 13/32 x 2 x 10 Ga.
38	179114	Pulley, Composite	156	166002	Washer Srrted 5/16 ID x 1.125
39	74760648	Bolt, Fin Hex 3/8-16 x 3	158	165589	Bracket Shift Mount
41	175556	Keeper, Belt Idler	159	165494	Hub Tapered Flange Shift Lt
47	127783	Pulley, Idler, V-Groove	161	72140406	Bolt Rdhd Sqnk 1/4-20 x 3/4 Gr 5
48	154407	Bellcrank Clutch Grnd Drv STL	162	73680400	Nut Crownlock 1/4-20 Unc
49	123205X	Retainer, Belt	163	74780416	Bolt Hex Fin 1/4-20 Unc x 1 Gr 5
50	72110612	Bolt Carr Sh 3/8-16 x 1-1/2 Gr. 5	164	19091010	Washer 5/8 x .281 x 10 Ga
51	73680600	Nut Crownlock 3/8-16 UNC	165	165623	Bracket Pivot Lever
52	73680500	Nut Crownlock 5/16-18 UNC	166	166880	Screw 5/16-18 x 5/8
53	105710X	Link, Clutch	168	165492	Bolt Shoulder 5/16-18 x .561
55	105709X	Spring, Return, Clutch	169	165580	Plate Fastening Lt
56	17060620	Screw 3/8-16 x 1-1/4	197	169613	Nyliner Snap-In 5/8" ID
57	140294	V-Belt, Ground Drive	198	169593	Washer Nyl 7/8 ID x .105
59	169691	Keeper, Center Span	199	169612	Bolt Shoulder 5/16-18 Unc
61	17120614	Screw 3/8-16 x .875	200	72140508	Bolt Rdhd Sqnk 5/16-18 Unc x 1
62	8883R	Cover, Pedal	202	72110614	Bolt Carr Sh 3/8-16 x 1-3/4 Gr 5
63	175410	Pulley, Engine	212	145212	Nut Hex flange Lock
64	71170764	Bolt, Hex	250	17060612	Screw Thdrol. 3/8-16 x .75
65	10040700	Washer			

**NOTE:** All component dimensions given in U.S. inches  
1 inch = 25.4 mm

TRACTOR - - MODEL NUMBER PD20H42STA PRODUCT NO. 954 56 95-09  
STEERING ASSEMBLY

[www.ersatzteil-service.de](http://www.ersatzteil-service.de)

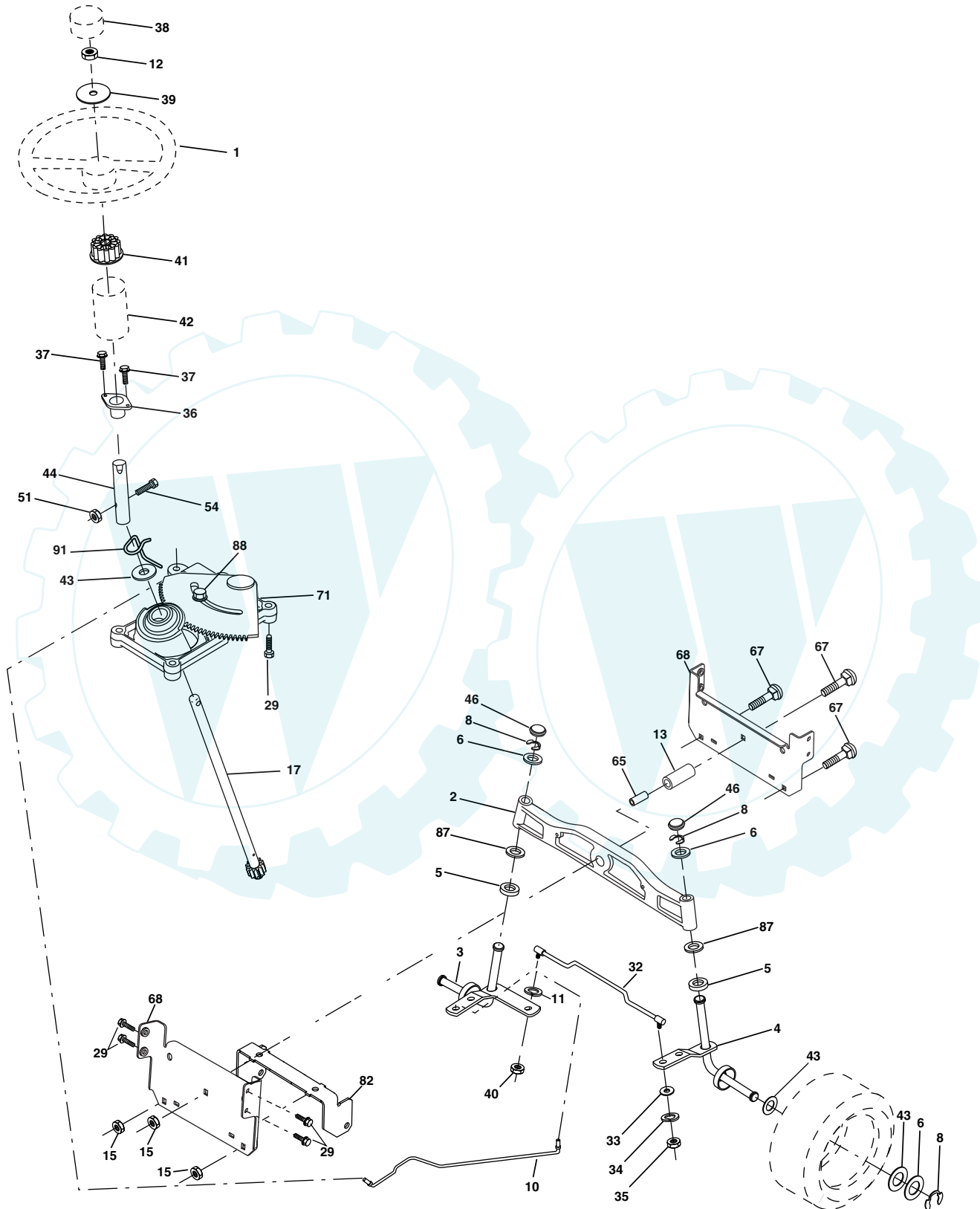



[www.ersatzteil-service.de](http://www.ersatzteil-service.de)

**TRACTOR - - MODEL NUMBER FD20H425TA PRODUCT NO. 954 56 95-09**  
**STEERING ASSEMBLY**

KEY NO.	PART NO.	DESCRIPTION
1	180656	Wheel Steering
2	172393	Axle Asm Cast Iron LT
3	169840	Spindle Asm LH
4	169839	Spindle Asm RH
5	6266H	Bearing Race Thrust Harden
6	121748X	Washer 25/32 X 1-5/8 X 16 Ga
8	12000029	Ring Klip #t5304-75
10	175121	Link Drag
11	10040600	Washer Lock Hvy Hlcl Spr 3/8
12	73940800	Nut Hex Jam Toplock 1/2-20 UNF
13	136518	Spacer Brg Axle Front
15	145212	Nut Hex Flange Lock
17	180641	Shaft Asm Steering
29	17060612	Screw 3/8-16 x .75
32	171888	Rod Tie
33	19111216	Washer 11/32 x 3/4 x 16 Ga
34	10040500	Washer Lock Hvy Hlcl Spr 5/16
35	73540500	Crownlock Nut 5/16-24 Unf
36	155099	Bushing Strg
37	152927	Screw
38	180657	Insert Cap Strg Wh
39	19182411	Washer 9/16 X 1 1/20 X 11 Ga
40	7810H	Lock nut
41	159945	Adaptor Wheel Strg
42	145054X428	Boot Steering Dash
43	121749X	Washer 25/32 X 1 1/4 X 16 Ga
44	180640	Extension Steering Shaft
46	121232X	Cap Spindle Fr Top Blk
51	73540400	Nut Crownlock 1/4-28
54	71130420	Bolt Hex 1/4-28 UNF x 1-1/4 Gr. 8
65	160367	Spacer Brace Axle
67	72140618	Bolt Rdhd Sq 3/8-16 Unc x 2-3/4
71	175146	Steering Asm
68	169827	Axle, Brace
82	169835	Bracket Susp Chassis Front
87	173966	Washer Flat .781 x 1-1/2 x .14
88	175118	Bolt Shoulder 7/16-20 Unc
91	175553	Clip Steering

**NOTE:** All component dimensions given in U.S. inches  
1 inch = 25.4 mm

TRACTOR - - MODEL NUMBER PD20H42STA PRODUCT NO. 954 56 95-09  
SEAT ASSEMBLY

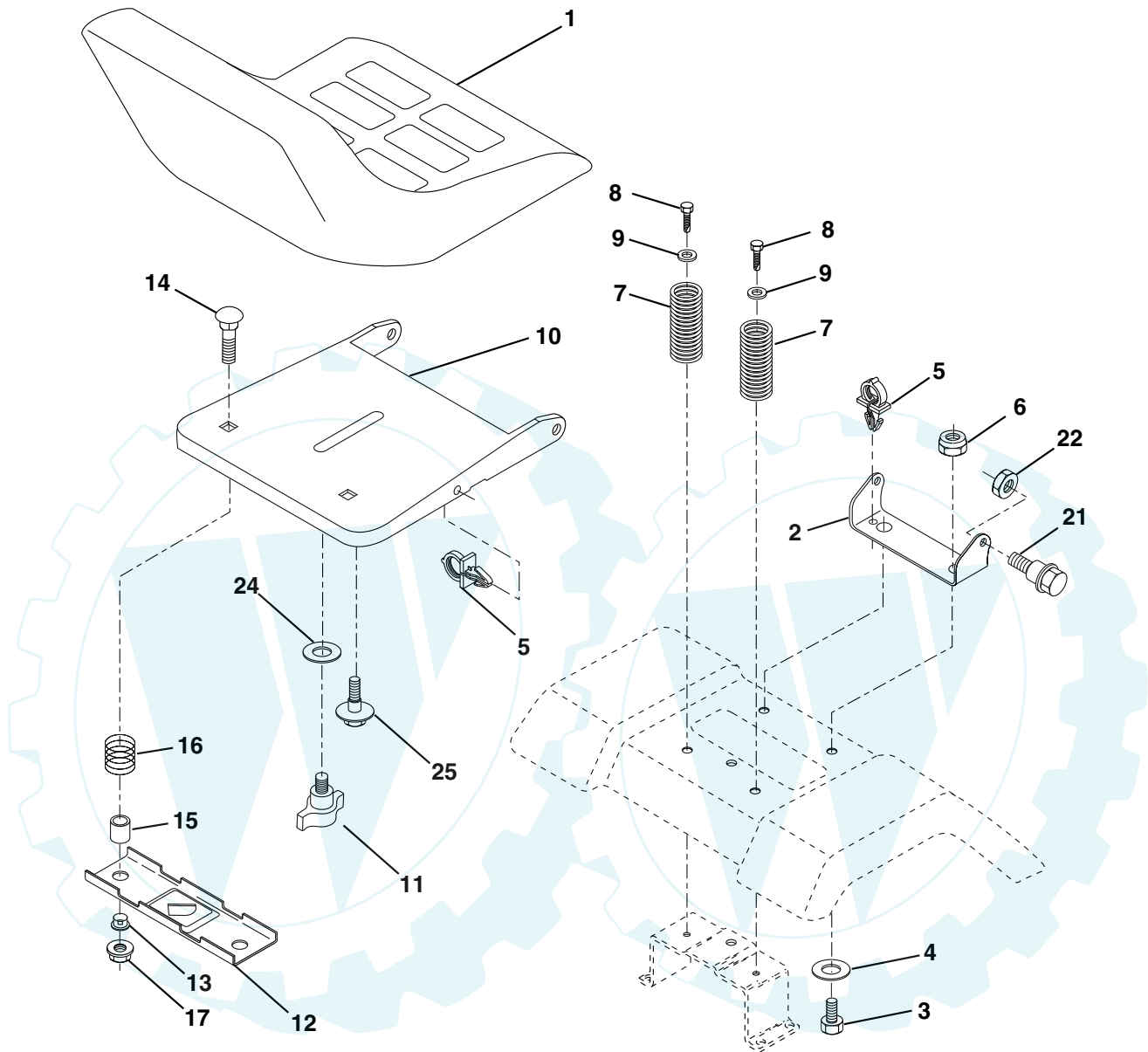

KEY NO.	PART NO.	DESCRIPTION
1	171683	Seat
2	140551	Bracket Pivot Seat 8 720
3	71110616	Bolt Fin Hex 3/8-16unc X 1
4	19131610	Washer 13/32 X 1 X 10 Ga
5	145006	Clip Push-In
6	73800600	Nut Hex w/Ins. 3/8-16 Unc
7	124181X	Spring Seat Cprsn 2 250 Blk Zi
8	17000616	Screw 3/8-16 x 1.5 Smgml
9	19131614	Washer 13/32 X 1 X 14 Ga.
10	182493	Pan Seat
11	166369	Knob Seat
12	121246X	Bracket Mounting Switch

KEY NO.	PART NO.	DESCRIPTION
13	121248X	Bushing Snap Blk Nyl 50 Id
14	72050412	Bolt Rdhd Sqnk 1/4-20x1-1/2
15	134300	Spacer Split 28x 88
16	121250X	Spring Cprsn
17	123976X	Nut Lock 1/4 Lge Flg Gr 5 Zinc
21	171852	Bolt Shoulder 5/16-18 Unc
22	73800500	Nut Hex Lock W/Ins 5/16-18
24	19171912	Washer 17/32 X 1-3/16 X 12 Ga.
25	127018X	Bolt Shoulder 5/16-18 X 62

**NOTE:** All component dimensions given in U.S. inches  
1 inch = 25.4 mm

# TRACTOR - - MODEL NUMBER FD20H2STA PRODUCT NO. 954 56 95-09 DECALS

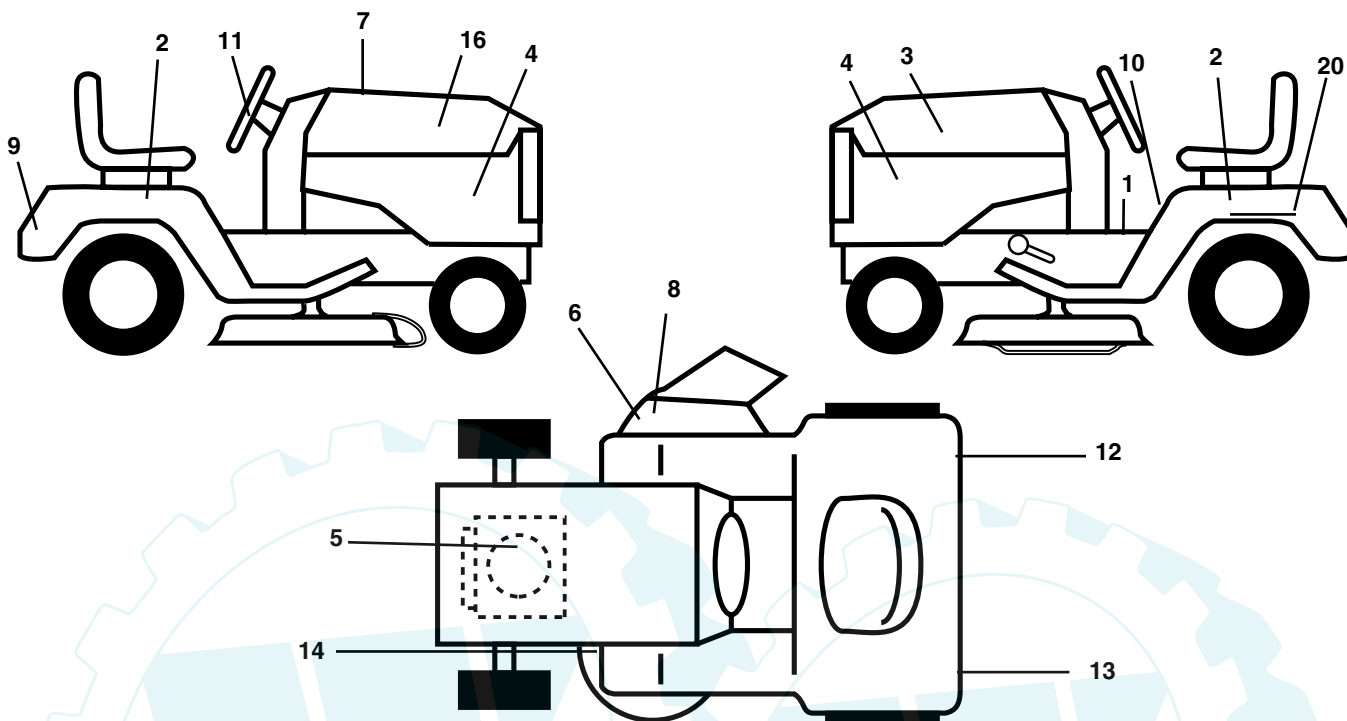

KEY NO.	PART NO.	DESCRIPTION
1	157032	Decal Oper
2	176303	Decal Fender Auto
3	186164	Decal Hood LH
4	185809	Decal Side Panel Logo
5	170851	Decal HP Engine
6	170563	Decal Warning, Keep Hand Away
7	185440	Decal Replacement Parts
8	179128	Decal Deck "B" 42"
9	172740	Decal Fender Logo
10	157140	Decal Fender Danger E/F
11	172743	Decal Ins Strg Whl
12	173587	Decal Fend Reflector Rh

KEY NO.	PART NO.	DESCRIPTION
13	173589	Decal Fend Reflector Lh
14	160396	Decal V-Belt Schematic
16	186163	Decal Hood Rh
20	145005	Decal Bat Dan/Psn
--	169210	Decal By Pass Lt Hydro
--	179768X428	Pad Footrest LH
--	179769X428	Pad Footrest RH
--	138311	Decal Handle Lft Height Adjust
--	<b>184617</b>	Manual Owner's (English)
--	<b>184618</b>	Manual Owner's (French)

## WHEELS AND TIRES

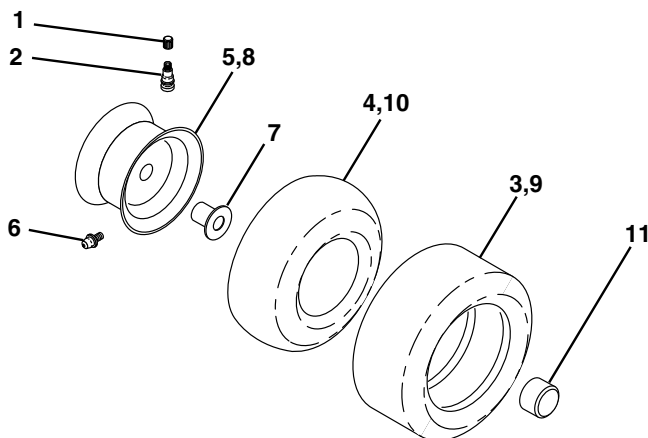

KEY NO.	PART NO.	DESCRIPTION
1	59192	Cap Valve Tire
2	65139	Stem Valve
3	170455	Tire F T 15 X 6 0 - 6 Service
4	59904	Tube Front (Service Item Only)
5	106732X421	Rim Asm 6"front Service
6	278H	Fitting Grease (Front Wheel Only)
7	9040H	Bearing Flange (Front Wheel nly)
8	106108X421	Rim Asm 8"rear Service
9	170456	Tire R T 20x10-8 Service
10	7152J	Tube Rear (Service Item Only)
11	104757X421	Cap Axle Blk 1 50 X 1 00
--	144334	Sealant, Tire ( 10 oz. Tube)

**NOTE:** All component dimensions given in U.S. inches  
1 inch = 25.4 mm

TRACTOR - - MODEL NUMBER PD20H42STA PRODUCT NO. 954 56 95-09  
ENGINE

[www.ersatzteil-service.de](http://www.ersatzteil-service.de)

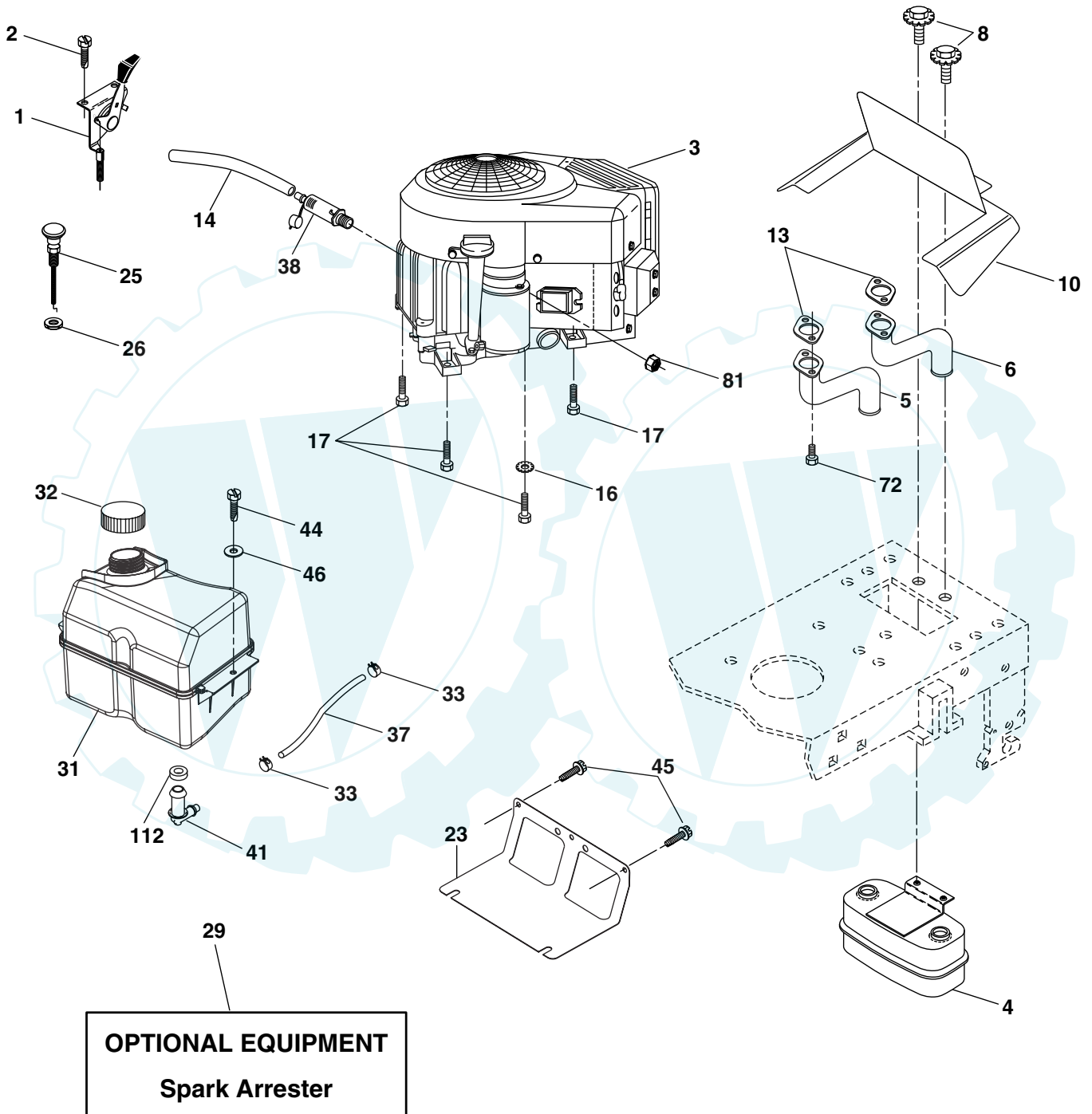

# TRACTOR - - MODEL NUMBER FD20H2S1A PRODUCT NO. 954 56 95-09 ENGINE

KEY NO.	PART NO.	DESCRIPTION
1	170771	Control, Throttle
2	17720408	Screw Hex Thd Cut 1/4-20 x 1/2
3	-----	Engine Briggs Model 407777 (Order Parts from Engine Mfg.)
4	149723	Muffler, Asm. Twin Lo-Tone
5	160589	Pipe Exhaust Intek 20 RH
6	159955	Pipe Exhaust Intek 20 LH
8	171877	Bolt 5/16-18 UNC x 3/4 w/Sems
10	162797	Shield Browing B&S Intek II
13	165391	Muffler Gasket
14	148456	Tube Oil Drain
16	11050600	Washer, Lock Ext tooth 3/8
17	17060624	Screw 3/8-16 x 1-1/2
23	169837	Shield, Browning/Debris Guard
25	145996	Control Choke
26	73920600	Nut Keps 3/8-24 UNF
29	137180	Arrester, Spark
31	185534	Tank, Fuel
32	140527	Cap Gauge, Fuel
33	123487X	Clamp, Hose Blk
37	137040	Line, Fuel 7.5
38	181654	Plug Drain Oil Easy
41	139277	Stem Tank Fuel
44	17670412	Screw Hex Wsh Thdrol 1/4-20 x 3/4
45	17000612	Screw Hex Wsh Thdrol 3/8-16 x 3/4
46	19091416	Washer 9/32 x 7/8 x 16 Ga.
72	183906	Screw Socket Head 5/16-18 x 1
81	73510400	Nut Keps Hex 1/4-20 Unc
112	3645J	Bushing

**NOTE:** All component dimensions given in U.S. inches  
1 inch = 25.4 mm

TRACTOR -- MODEL NUMBER PD20H42STA PRODUCT NO. 954 56 95-09  
MOWER DECK

[www.ersatzteil-service.de](http://www.ersatzteil-service.de)

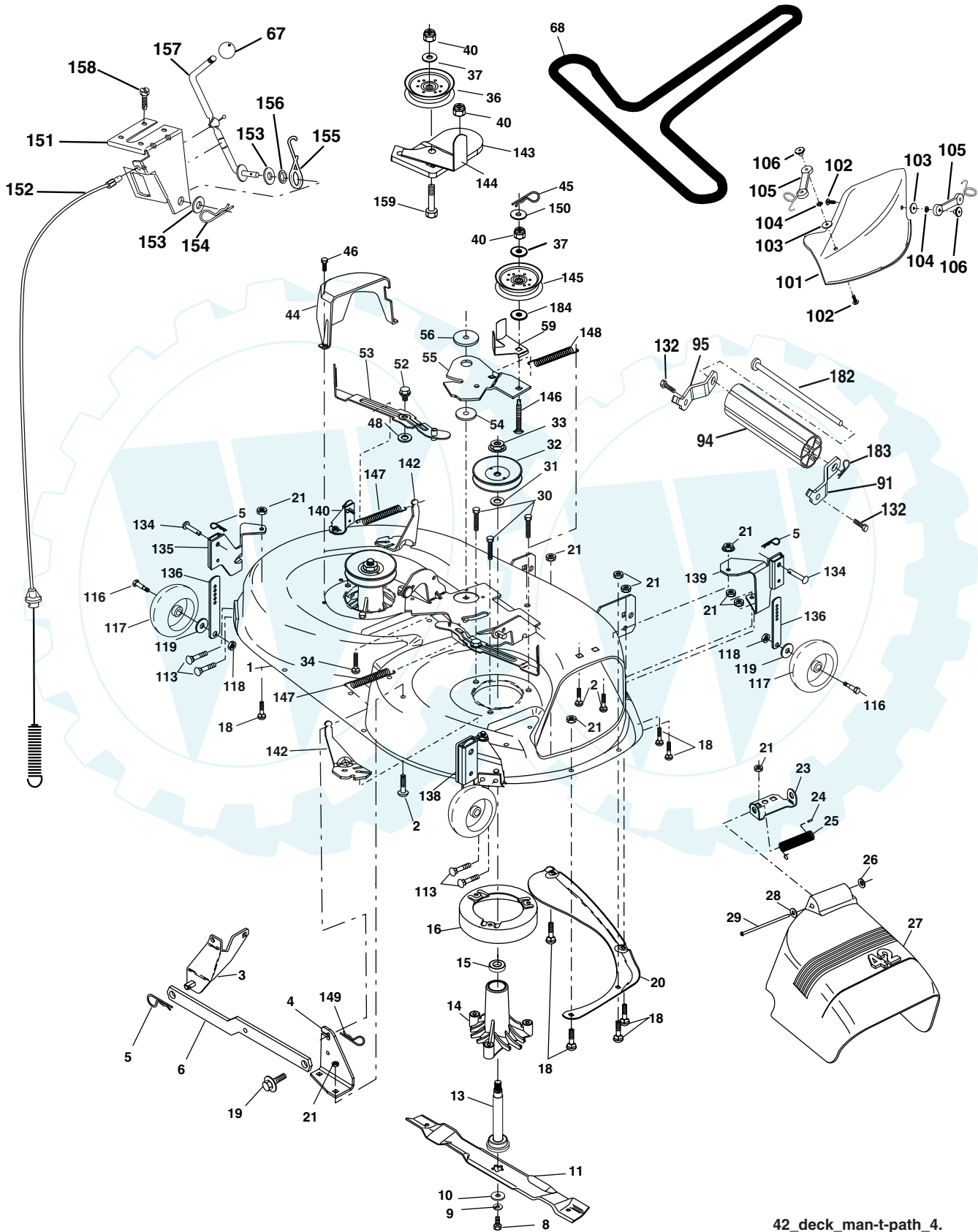

42\_deck\_man-t-path\_4.



**TRACTOR - - MODEL NUMBER FD20H2STA PRODUCT NO. 954 56 95-09  
MOWER DECK**

KEY NO.	PART NO.	DESCRIPTION	KEY NO.	PART NO.	DESCRIPTION
1	182032X421	Mower Deck Assembly, 42"	91	180532	Bracket Asm Noseroller LH
2	72140506	Bolt	94	132264	Roller Nose 38 & 42
3	138017	Bracket Asm Fr. Sway Bar 3/42	95	180533	Bracket Asm Noseroller RH
4	165460	Bracket Asm Deck 42" Sway Bar	101	136420	Mulcher Cover
5	4939M	Retainer Spring	102	71081010	Screw, Pan Hd Phillip 10-24 x 5/8
6	178024	Bar Sway Deck	103	19061216	Washer, Flat
8	850857	Bolt 3/8-24 x 25 Grade 8 patched	104	10071000	Washer, Lock
9	10030600	Washer, Lock	105	160793	Latch Assembly
10	140296	Washer, Hardened	106	2029J	Nut, Weld
		(The following Blades are available)	113	17060512	Screw 5/16-18 x 3/4
11	134149	Blade, Mulching 42" Std (for mulching mowers only)	116	137644	Bolt, Shoulder
	139775	Blade Mulching 42" Premium (For better wear when mulching)	117	133957	Wheel, Gauge
	138971	Blade Mower 42" Hi-Lift (for bagging and discharging)	118	73930600	Nut Centerlock 3/8-16
13	137645	Shaft Assembly, Mandrel, Vented	119	19121414	Washer 3/8 x 7/8 x 14 Ga.
14	128774	Housing, Mandrel, Vented	132	17000612	Screw 3/8-16 x .75
15	110485X	Bearing, Ball, Mandrel	134	156941	Pin Head Rivet
16	174493	Stripper, Mandrel Deck	135	159765X421	Bracket Asm. Whl Ga. R LH
18	72140505	Bolt, Carriage 5/16-18 x 5/8	136	155986	Bar Adjusting Gauge Wheel
19	132827	Bolt, Shoulder	138	159763X421	Bracket Asm Whl Ga. R RH
20	159770	Baffle, Vortex	139	159767X421	Bracket Asm. Whl Ga. F RH
21	73680500	Nut	140	159768X421	Bracket Asm Whl Ga. F LH
23	177563	Bracket, Deflector Mower 42"	142	165890	Arm Spring Brake Mower
24	105304X	Cap, Sleeve 80 x 112 Blk Mower	143	157109	Bracket Arm Idler 42"
25	123713X	Spring, Torsion, Deflector 2 52	144	173441	Keeper Belt 42" Clutch Cable
26	110452X	Nut, Push Phos & Oil	145	173437	Pulley Idler Flat
27	130968X428	Shield, Deflector 42" Blk	146	173443	Bolt Carriage Idler
28	19111016	Washer 11/32 x 5/8 x 16 Gauge	147	131335	Spring Extension
29	131491	Rod, Hinge 42" 6 75 W/G	148	169022	Spring Return Idler
30	173984	Screw Thdrol	149	165898	Retainer Spring Yellow
31	129963	asher, Spacer Mower Vented	150	19091216	Washer 9/32 x 3/4 x 16 Ga.
32	173436	Pulley, Mandrel	151	169670	Bracket Clutch Cable
33	178342	Nut, Toplock	152	169676	Clutch Cable 42"
34	72110614	Bolt	153	169674	Washer Flat 3/8" Type B
36	173438	Pulley, Idler, Flat	154	169675	Spring Retainer
37	19131316	Washer 13/32 x 13/16 x 16 Gauge	155	169671	Spring Retention LVR CLTCH CAB
40	73680600	Nut	156	169672	Spacer Clutch Cable
44	140088	Guard, Mandrel, LH	157	169669	Rod Clutch Cable 3/8"
45	4497H	Retainer	158	17720408	Screw Hex Thd Cut 1/4-20 x 1/2
46	137729	Screw, Thdrol 1/4-20 x 5/8 T	159	72140614	Bolt Rdhd Sqn 3/8-16 UNC x 1-3/4
48	133944	Washer, Hardened	182	179126	Rod Roller Nose
52	139888	Bolt, Shoulder 5/16-18 UNC	183	163552	Retainer Spring
53	184907	Arm Assembly, Pad, Brake	184	19131410	Washer 13/32 x 7/8 x 10 Ga.
54	178515	Washer, Hardened	--	130794	Mandrel Assembly (Includes Housing Shaft and Shaft Hardware Only - Pulley Not Included)
55	155046	Arm, Idler	--	184563	Replacement Mower, Complete
56	122052X	Spacer, Retainer			
59	173442	Guard TUV Idler			
67	171598	Knob Round			
68	144959	V-Belt, 42" Mower			

**NOTE:** All component dimensions given in U.S. inches  
1 inch = 25.4 mm



TRACTOR - - MODEL NUMBER PD20H42STA PRODUCT NO. 954 56 95-09  
MOWER LIFT

[www.ersatzteil-service.de](http://www.ersatzteil-service.de)

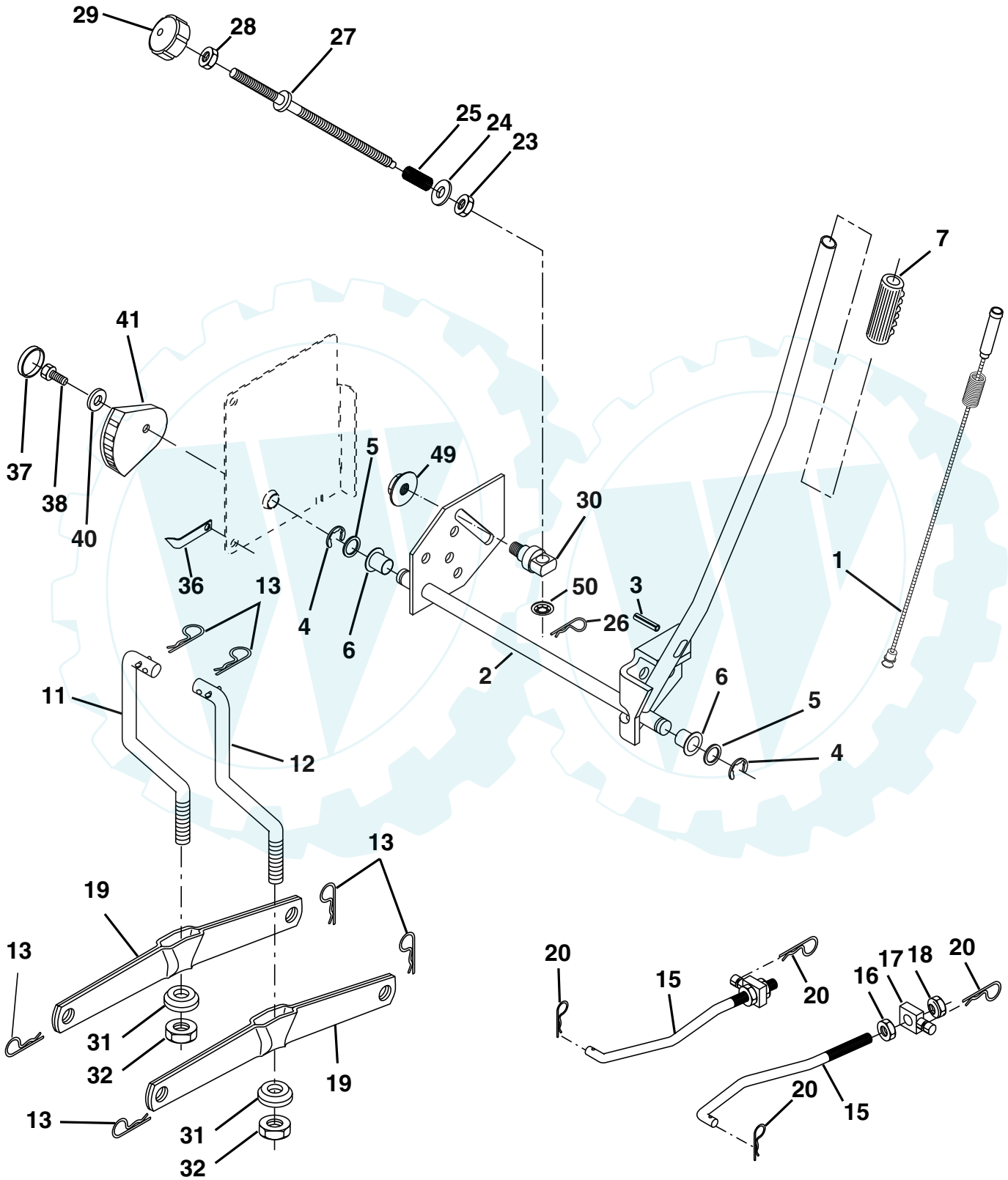

TRACTOR - - MODEL NUMBER FD20H2STA PRODUCT NO. 954 56 95-09  
MOWER LIFT

KEY NO.	PART NO.	DESCRIPTION
1	184418	Wire Asm Inner/Sprg W/plunger LT
2	159471	Shaft Asm Lift RH w/Inf
3	105767X	Pin Groove 1 500 Zinc
4	12000002	E Ring #5133-62
5	19211621	Washer 21/32 X 1 X 21 Ga
6	120183X	Bearing Nylon Blk 629 Id
7	175830	Grip Handle
11	139865	Link Lift LH Fixed Length
12	139866	Link Lift RH Fixed Length
13	4939M	Retainer Spring
15	173288	Link Front
16	73350800	Nut Jam Hex 1/2-13 Unc
17	175689	Trunnion
18	73800800	Nut Lock W/Wsh 1/2-13 Unc
19	139868	Arm Suspension Rear
20	163552	Retainer Spring
23	110807X	Nut Special
24	19131016	Washer 13/32 X 5/8 X 16 Ga
25	2876H	Spring 2-1/8"
26	169484	Retainer Clip
27	126971X	Rod Adj Lift Zinc 7.49 Wrk Lg
28	73350600	Nut Hex Jam 3/8-16 Unc
29	138057	Knob Inf 3/8-16 Unc Blk W/sym
30	150233	Trunnion Infin Height
31	169865	Bearing Pvt Lift
32	73540600	Nut Crownlock 3/8 - 24
36	155097	Pointer Height Indicator
37	123935X	Plug Hole Blk 1.485/1.515 Dia.
38	17060516	Screw 5/16-18 x 1
40	19112410	Washer 11/32 x 1-1/2 10 Ga.
41	155098	Indicator Height STLT
49	145212	Nut Hex Flange Lock
50	110452X	Nut PUSh Phos & Oi

**NOTE:** All component dimensions given in U.S. inches  
1 inch = 25.4 mm