

**TRACTOR - - MODEL NO. GTH2548 (LOGT25H48B) PRODUCT NO. 954 57 21-34 SCHEMATIC**

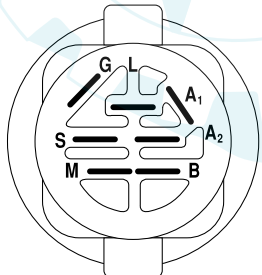
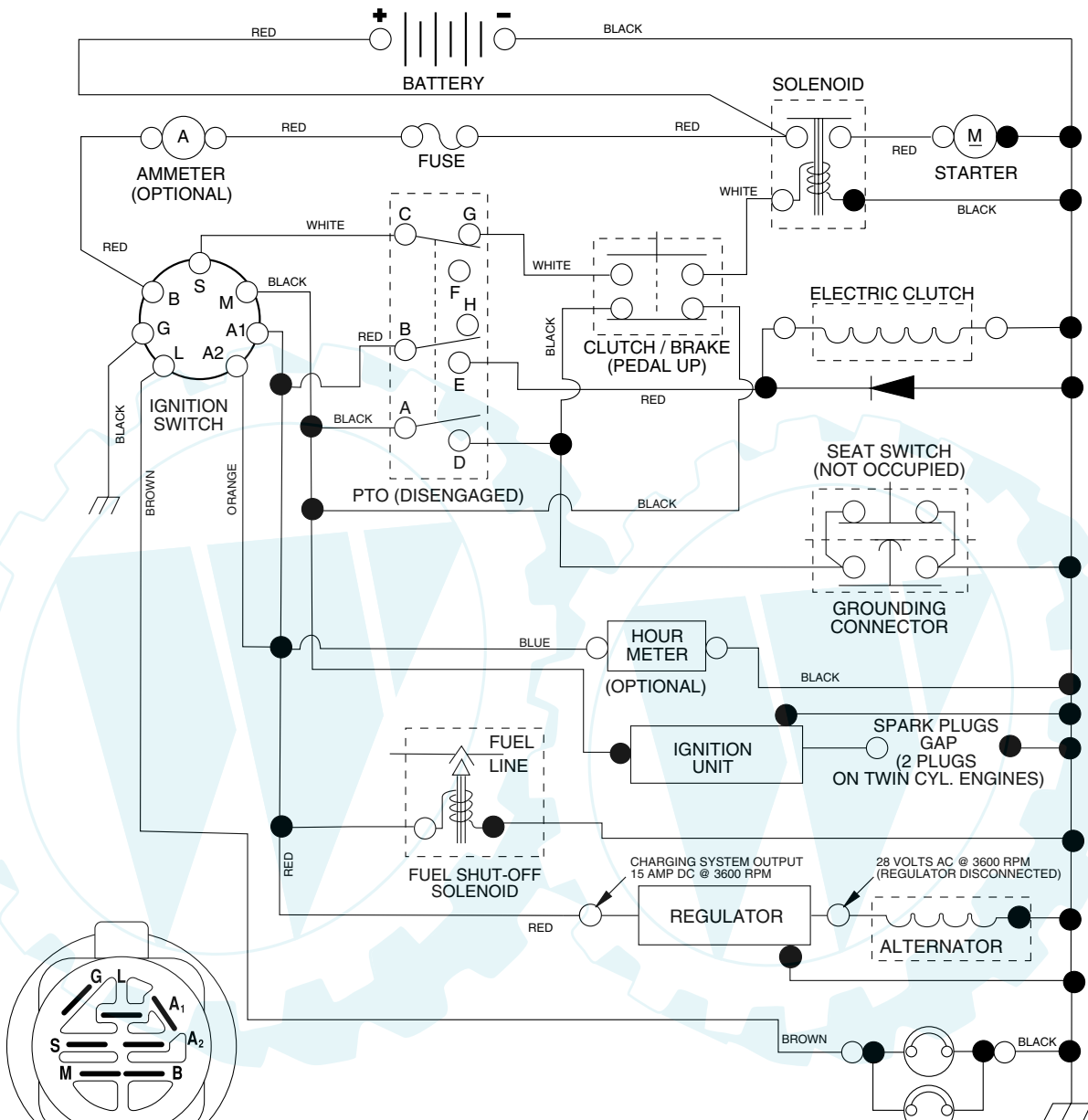

**IGNITION SWITCH**

POSITION	CIRCUIT	"MAKE"
OFF	M + G + A1	NONE
ON + LIGHTS	B + A1	L + A2
ON	B + A1	NONE
START	B + S + A1	NONE

**WIRING INSULATED CLIPS**  
**NOTE:** IF WIRING INSULATED CLIPS WERE REMOVED FOR SERVICING OF UNIT, THEY SHOULD BE REPLACED TO PROPERLY SECURE YOUR WIRING.

**PTO SWITCH**

POSITION	CIRCUIT
OFF	C + G, B + H
ON	C + F, B + E, A + D

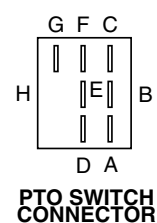

# REPAIR PARTS

TRACTOR - - MODEL NO. GTH2548 (LOGT25H48B) PRODUCT NO. 954 57 21-34  
ELECTRICAL

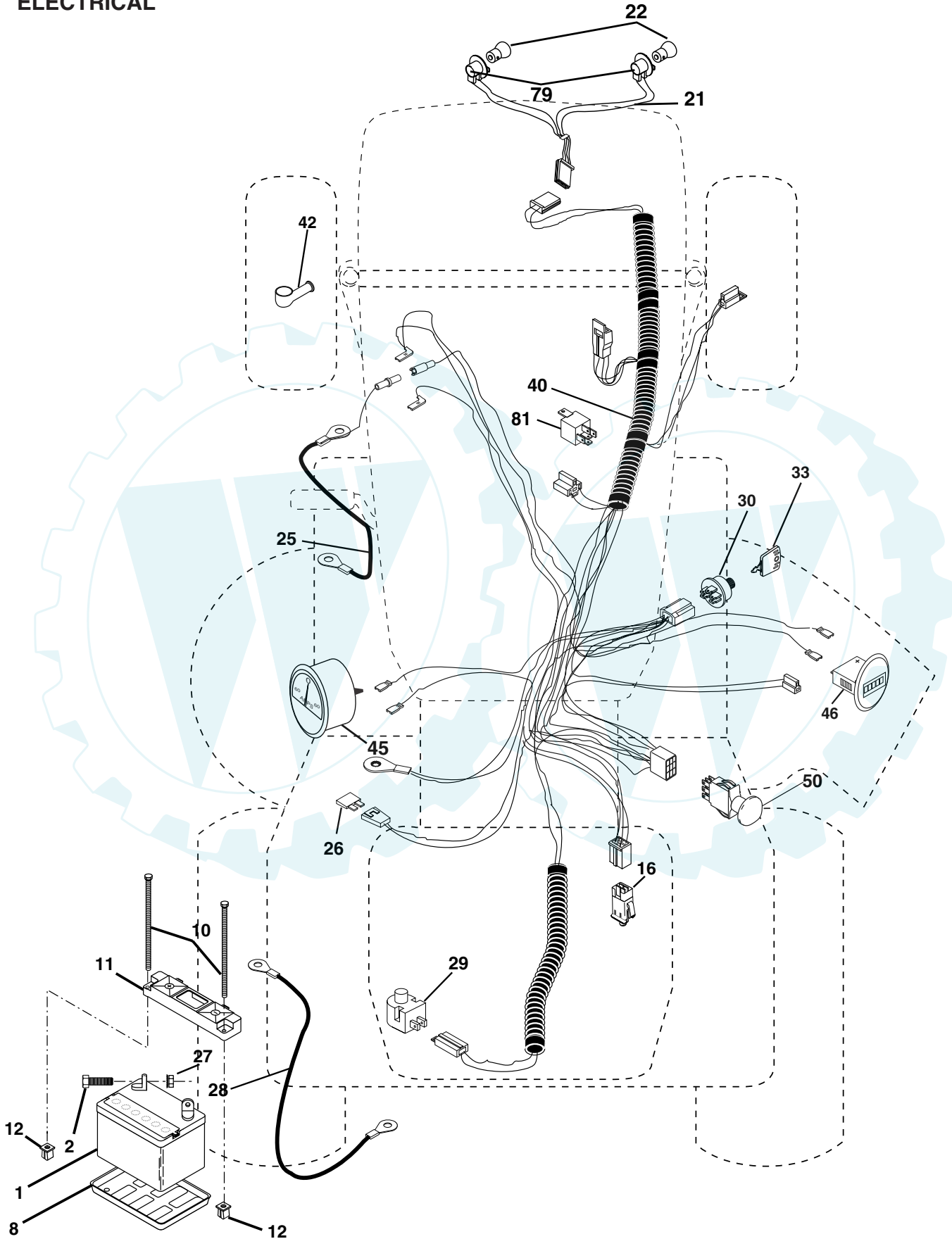

## REPAIR PARTS

TRACTOR - - MODEL NO. GTH2548 (LOGT25H48B) PRODUCT NO. 954 57 21-34  
ELECTRICAL

KEY NO.	PART NO.	DESCRIPTION
1	532 14 49-27	Battery
2	874 76 04-12	Bolt Hex Head 1/4-20 x 3/4
8	532 12 48-86	Tray, Battery
10	532 14 52-11	Bolt, Battery Front 1/4-20 x 7.5 Zinc
11	532 15 01-09	Holddown Battery Front Mount
12	532 14 57-69	Nut, Push Nylon 1.4" Battery Front
16	532 17 61-38	Switch Interlock Push-In
21	532 17 56-88	Harness Socket Light w/4152J
22	532 00 41-52	Bulb Light
25	532 18 54-56	Cable
26	532 10 88-24	Fuse
27	873 51 04-00	Nut Keps Hex 1/4-20
28	532 17 06-97	Cable Bolt Ground
29	532 12 13-05	Switch, Plunger NC Gray
30	532 18 96-87	Switch, Ign
33	532 14 04-01	Key
40	532 18 80-34	Harness Ign.
42	532 15 43-36	Cover, Terminal Red
45	532 17 75-00	Ammeter
46	532 17 75-01	Hourmeter
50	532 17 46-51	Switch, PTO
79	532 17 52-42	Bulbholder Asm
81	532 10 97-48	Relay Asm.

**NOTE:** All component dimensions given in U.S. inches  
1 inch = 25.4 mm

# REPAIR PARTS

TRACTOR - - MODEL NO. GTH2548 (LOGT25H48B) PRODUCT NO. 954 57 21-34  
CHASSIS AND ENCLOSURES

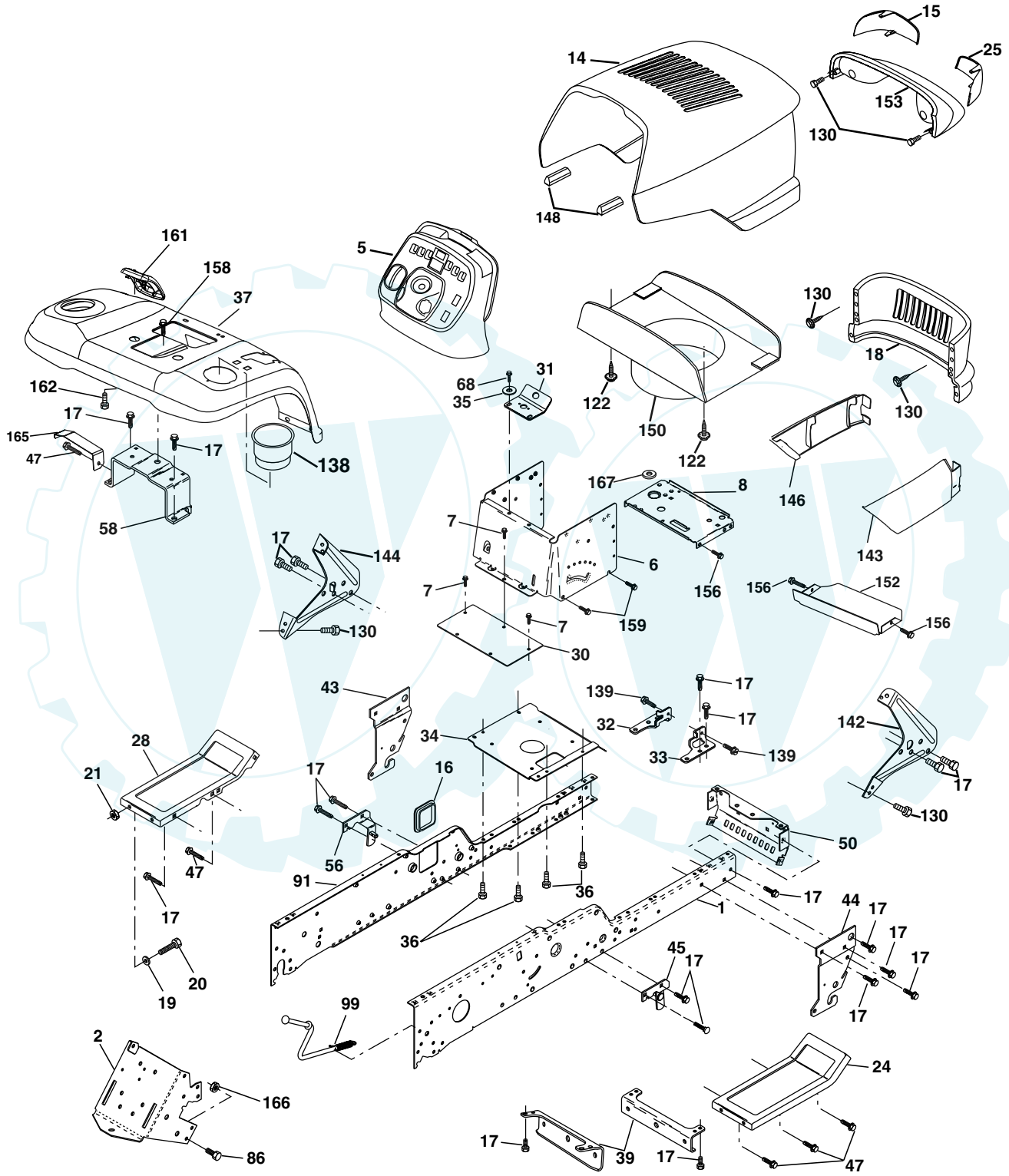

chassis-stealth\_44

# REPAIR PARTS

## TRACTOR - - MODEL NO. GTH2548 (LOGT25H48B) PRODUCT NO. 954 57 21-34 CHASSIS AND ENCLOSURES

KEY NO.	PART NO.	DESCRIPTION	KEY NO.	PART NO.	DESCRIPTION
1	532 18 03-75	Rail, Kit RH	50	532 17 54-76	Bracket, Chassis Front
2	532 17 52-82	Drawbar, Gt	56	532 17 60-16	Bracket Asm., Susp Chassis Lh
5	532 19 00-54	Dash	58	532 18 35-69	Bracket Asm., Fender
6	532 15 78-82	Dash, 1PCS, Lower	68	817 49 05-08	Screw, 5/16-18 x 1/2
7	817 72 04-08	Screw, Thd Cut 1/4-20 x 1/2	86	874 78 07-16	Bolt, Fin Hex 7/16-14 unc
8	532 18 46-68	Support, Battery	91	532 18 03-74	Rail, Kit Lh
14	532 19 00-55	Hood Asm., Pnt	99	532 17 71-43	Rod Asm. Bypass
15	532 16 18-41	Lens LH	122	532 16 14-64	Screw Hex WSHD 8-18 x 7/8
16	532 12 17-94	Cover, Access	130	532 17 18-75	Screw Hw Hd Hi-Lo #13-16 x 3/4
17	817 00 06-12	Screw, 3/8-16 x 3/4	138	532 18 17-98	Cupholder
18	532 18 28-73	Grille	139	532 17 18-73	Bolt Shoulder 5/16-18
19	819 13 13-12	Washer 13/32 x 13/16 x 12 Ga.	142	532 16 18-97	Bracket Dash Stealth RH
20	874 78 06-16	Bolt, Fin Hex 3/8-16 x 1	143	532 17 75-86	Skirt Grille RH
21	873 80 06-00	Nut, Crownlock 3/8-16	144	532 16 19-00	Bracket Dash Stealth LH
24	532 18 10-58	Footrest, RH	146	532 17 75-87	Skirt Grille LH
25	532 16 18-42	Lens RH	148	532 16 46-55	Extrusion Bumper
28	532 18 10-57	Footrest, LH	150	532 19 03-09	Duct Heat Hood
30	532 14 50-52	Saddle	152	532 17 79-56	Shield, Browning
31	532 16 14-19	Bracket Supt 1-pc Vgt Steering	153	532 18 82-12	Lightbox Asm.
32	532 16 13-27	Bracket, Frame Pivot Lh	156	817 00 05-12	Screw 5/16-18 x 3/4
33	532 16 13-26	Bracket, Frame Pivot Rh	158	817 67 06-08	Screw 3/8-16 x 1/2
34	532 17 70-18	Plate Asm Engine Chassis	159	817 00 06-12	Screw Hexwsh Thdr. 3/8-16 x 3/4
35	819 11 11-16	Washer 11/32 x 11/16 x 16 Ga.	161	532 18 17-87	Cosole Fuel Window
36	817 06 05-12	Screw 5/16-18 x 3/4	162	532 14 24-32	Screw 1/4-1/2 Unc
37	532 18 17-20	Fender, Pnt.	165	532 18 35-54	Bracket Support Tank
39	532 17 52-78	Bracket, Axle Front	166	873 68 07-00	Nut, Lock Hex 7/16-14 unc
43	532 13 69-39	Bracket, Spnsn Front Lh	167	532 18 46-72	Bushing Snap Nylon 1.250
44	532 13 69-40	Bracket, Spnsn Front Rh			
45	532 17 60-18	Bracket Asm., Susp Chassis Rh			
47	817 49 06-08	Screw Thdrol 3/8-16 x 1/2			

**NOTE:** All component dimensions given in U.S. inches  
1 inch = 25.4 mm

# REPAIR PARTS

TRACTOR - - MODEL NO. GTH2548 (LOGT25H48B) PRODUCT NO. 954 57 21-34  
GROUND DRIVE

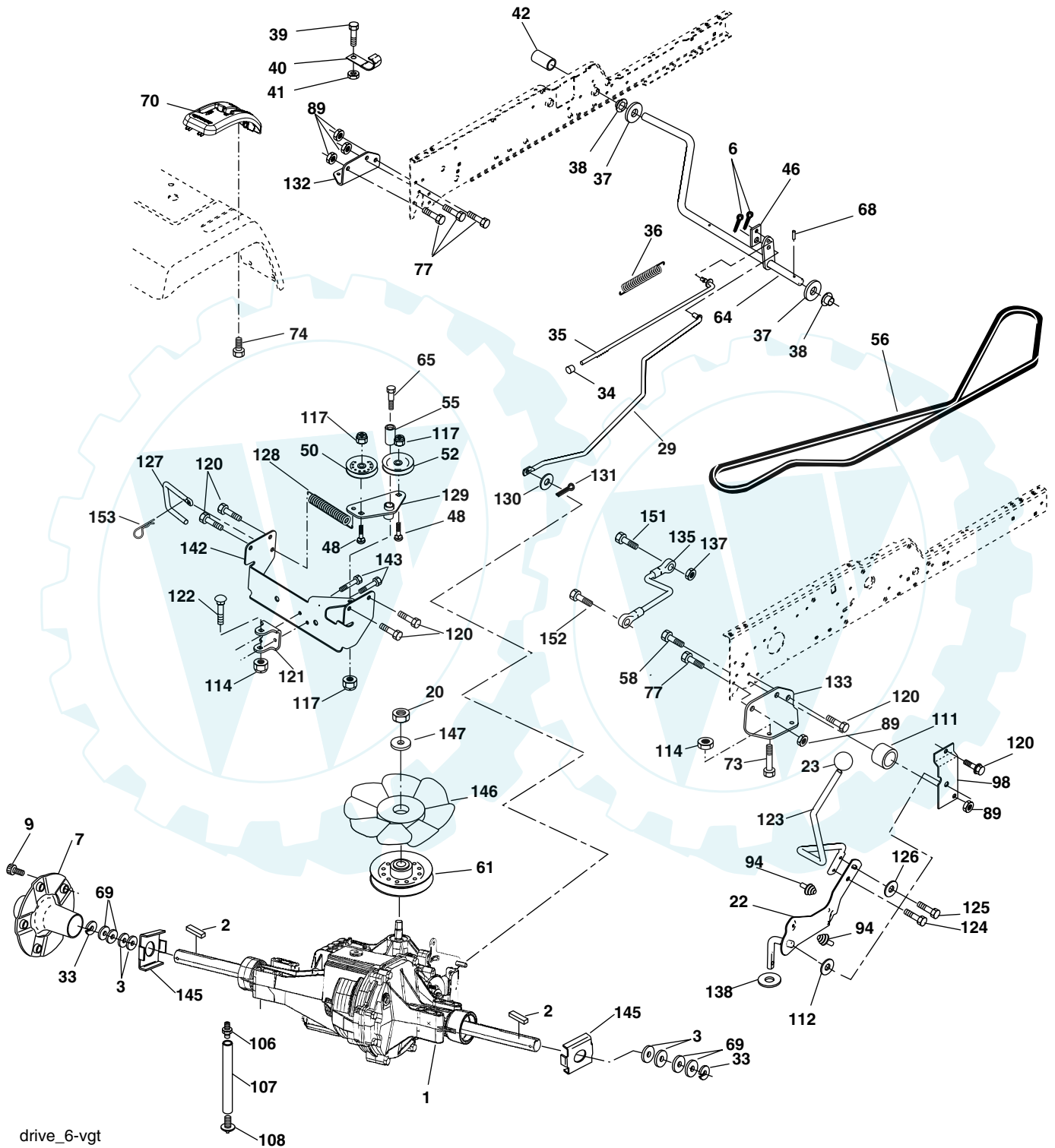

drive\_6-vgt



# REPAIR PARTS

**TRACTOR - - MODEL NO. GTH2548 (LOGT25H48B) PRODUCT NO. 954 57 21-34  
GROUND DRIVE**

KEY NO.	PART NO.	DESCRIPTION	KEY NO.	PART NO.	DESCRIPTION
1	-----	Transaxle Hydro Gear 331-3000 (Order Parts From Transaxle Manufacturer)	94	532 13 38-35	Fastener Christmas Tree
2	532 00 70-70	Key Sq. 1/4 x 1/4 x 2.5	98	532 14 10-04	Bracket Shift
3	532 00 75-63	Washer Thrust	106	532 14 29-18	O-Ring Asm Hydro Gear
6	876 02 04-12	Pin, Cotter	107	532 15 47-39	Line Fuel Hydro 15" VGT
7	532 14 05-07	Wheel, Hub Assembly	108	532 14 29-17	Cap Asm Vent Hydro Gear
9	532 14 00-80	Bolt, Hub	111	532 15 62-40	Spacer Shift Lever VGTH
20	873 94 08-00	Nut	112	532 17 85-58	Washer Nylon High Temp
22	532 18 02-35	Lever Asm Shift	114	873 80 05-00	Nut Lock Hex W/Ins 5/16-18 unc
23	532 14 08-45	Knob	117	873 90 06-00	Nut, Lock Flg. 3/8-16
29	532 17 66-00	Brake, Rod	120	817 00 06-12	Screw 3/8-16 x .75
33	812 00 00-53	Ring E	121	532 17 56-11	Bracket Strap Torque
34	532 07 16-73	Cap, Parking Brake	122	872 01 05-20	Bolt RDHDSQ 5/16-18 unc x 2-1/2
35	532 13 76-48	Rod, Parking Brake	123	532 18 32-54	Rod Shift
36	532 14 94-12	Spring, Drive Ground	124	532 16 54-92	Bolt Shoulder 5/16-18 x .561
37	532 12 17-49	Washer 25/32 x 1-1/4 x 16 Ga.	125	817 49 05-10	Screw 5/16-18 x 5/8
38	532 15 00-35	Nyliner	126	532 16 60-02	Washer SRRTD 5/16 ID x 1.0 x .125
39	874 32 10-16	Screw, Fin. #10-24 x 1	127	532 17 73-62	Link Control Clutch
40	532 17 85-75	Actuator, Interlock VGT	128	532 17 66-24	Spring Drive GRND
41	873 93 10-00	Nut Centerlock 10-24 unc	129	532 17 94-73	Bracket Asm Idler Tensioning
42	532 12 48-72	Cover, Pedal	130	819 13 10-16	Washer 13/32 x 5/8 x 16 Ga.
46	532 14 51-70	Retainer, Spring	131	876 02 03-12	Pin Cotter 3/32 x 3/4
48	872 11 06-14	Bolt Rdhd 3/8-16 x 1.3/4 Gr. 5	132	532 17 54-67	Bracket Mtg Hydro 3500 LH VGT
50	532 13 14-94	Pulley, Idler, Flat	133	532 17 54-68	Bracket Mtg Hydro 3500 RH VGT
52	532 12 77-83	Pulley, Idler, Grooved	135	532 17 73-64	Link Asm Control Hydro 3500
55	532 10 57-06	Bearing, Idler	137	532 12 49-49	Nut Lock 5/16-18 NC Thd.
56	532 16 15-97	V-Belt	138	532 00 13-70	Washer Thrust 5/8 x 1.10 x 1/32
58	874 76 07-24	Bolt Fin Hex 7/16-14 x 1-1/2	142	532 17 54-69	Strap Torque HG-3500
61	532 14 39-95	Pulley, Transaxle	143	817 06 05-12	Screw Thdrol 5/16-18 x 3/4
64	532 17 66-01	Shaft, Brake Pedal	145	532 16 31-68	Washer Axle Flange HG-3000
65	532 17 96-13	Bolt, Shoulder	146	532 14 04-62	Fan 7" Hydro
68	532 00 51-42	Pin, Roll	147	532 14 13-22	Washer
69	532 12 38-00	Washer	151	874 76 05-14	Bolt Hex 5/16-18 x 7/8
70	532 18 17-88	Console Automatic YT/GT	152	532 17 87-05	Bolt Hex 5/16 x 1 W/Patch
73	874 49 05-48	Bolt Hex Flghd 5/16-18 x 3 Gr. 5	153	532 12 47-88	Spring, Retainer
74	532 14 24-32	Screw Hex Wsh. Hi-Lo 1/4-1/2			
77	874 78 07-16	Bolt Fin Hex 7/16-14 x 1			
89	873 68 07-00	Nut Crownlock 7/16-14 unc			

**NOTE:** All component dimensions given in U. S. inches 1 inch = 25.4 mm

# REPAIR PARTS

TRACTOR - - MODEL NO. GTH2548 (LOGT25H48B) PRODUCT NO. 954 57 21-34  
STEERING ASSEMBLY

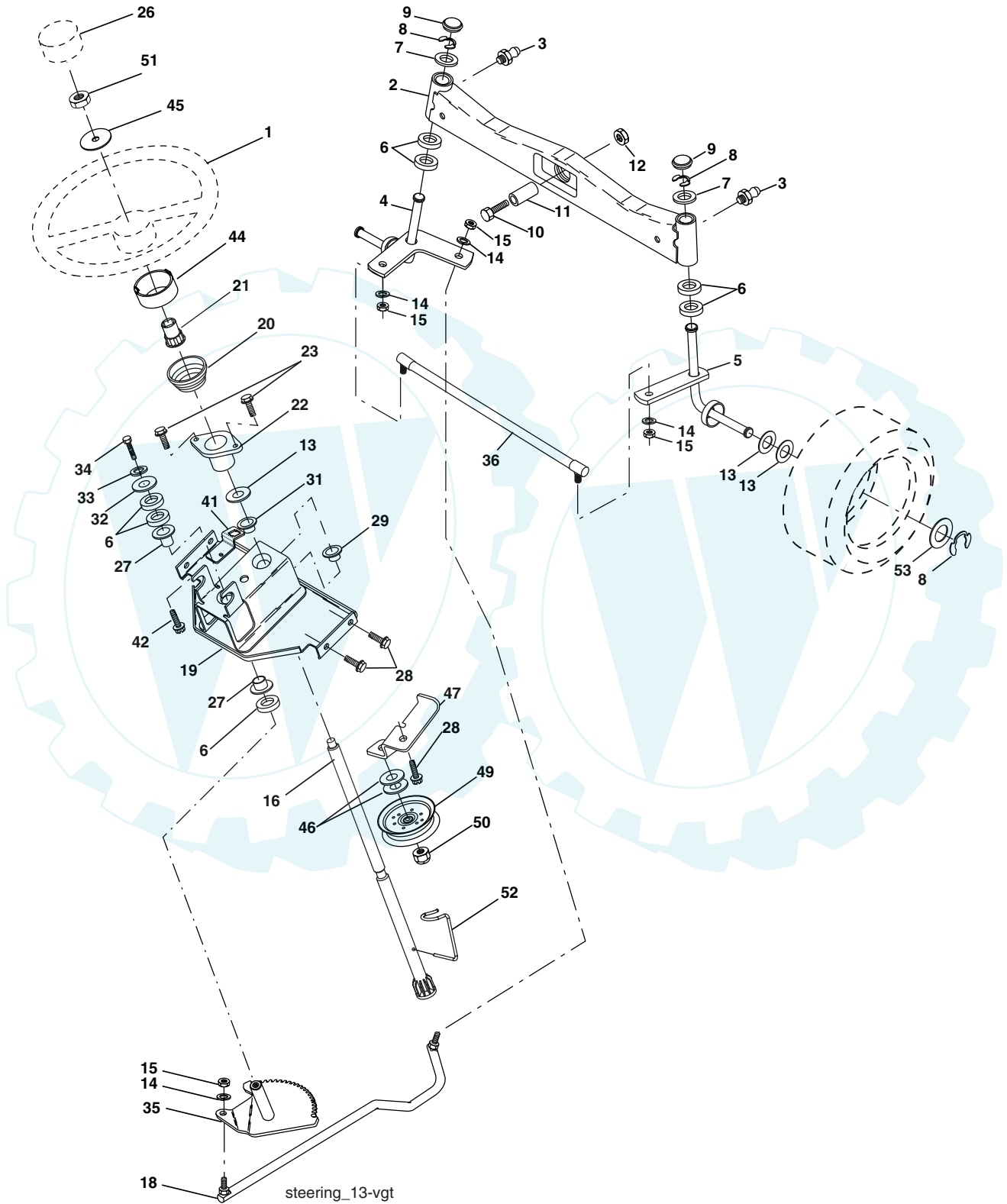



# REPAIR PARTS

TRACTOR - - MODEL NO. GTH2548 (LOGT25H48B) PRODUCT NO. 954 57 21-34  
STEERING ASSEMBLY

KEY NO.	PART NO.	DESCRIPTION
1	532 16 66-27	Wheel, Steering
2	532 17 85-57	Axle Asm., Front
3	532 18 32-26	Fitting, Grease
4	532 16 18-49	Spindle Asm, LH
5	532 16 18-48	Spindle Asm., RH
6	532 12 49-31	Bearing, Race Thrust Harden
7	532 12 17-48	Washer 25/32 x 1-5/8 x 16 Ga.
8	812 00 00-29	Ring, Klip #T5304-75
9	532 12 12-32	Cap, Spindle
10	874 78 10-44	Bolt, Fin Hex 5/8-11 x 2-3/4
11	532 13 65-18	Spacer Brg Axle Front 1.570
12	873 90 10-00	Nut, Lock Flange 5/8-11 unc
13	532 12 17-49	Washer 25/32 x 1-1/4 x 16 Ga.
14	810 04 06-00	Washer, Lock Hvy Hlcl Spr 3/8
15	873 54 06-00	Nut Crownlock 3/8-24
16	532 18 68-14	Shaft Asm., Steering
18	532 17 55-72	Draglink, Ball Joint Solid Vgt
19	532 15 60-11	Support Asm., Steering Vgt
20	532 17 75-92	Boot Steering
21	532 15 99-45	Adapter, Wheel Steering
22	532 15 51-05	Bushing, Strg.
23	532 15 29-27	Screw
26	532 16 66-26	Cap , Wheel Steering
27	532 12 49-37	Bearing, Col. Strg.
28	817 00 06-12	Screw 3/8-16 x 3/4
29	532 10 42-39	Bearing, Flange
31	532 13 81-36	Bushing, Nyliner Snap
32	819 11 16-10	Washer 11/32 x 1 x 10 Ga.
33	810 04 05-00	Washer, Lock Hvy Hlcl Spr 5/16
34	874 78 05-12	Bolt, Hex Hd 5/16-18 x 3/4
35	532 18 70-39	Gear, Sector Steering
36	532 18 67-99	Tie Rod
41	532 15 52-46	Bracket Switch Inerlock VGT97
42	817 49 05-08	Screw 5/16-18 x 1/2
44	532 17 75-93	Extension Steering Premium
45	819 18 24-11	Washer 9/16 ID x 1 1/2 OD 11 Ga. Zin
46	819 13 16-10	Washer 13/32 x 1 x 10 Ga.
47	532 17 94-71	Bracket Asm. Idler
49	532 17 58-20	Pulley Idler Flat
50	873 90 06-00	Nut Lock Flg 3/8-16 unc
51	873 94 08-00	Nut Hex Jam Toplock 1/2-20 unf
52	532 17 55-53	Clip Steering .750
53	532 18 89-67	Washer Harden .793 x 1.63 x 060

**NOTE:** All component dimensions given in U.S. inches  
1 inch = 25.4 mm

# REPAIR PARTS

TRACTOR - - MODEL NO. GTH2548 (LOGT25H48B) PRODUCT NO. 954 57 21-34  
ENGINE

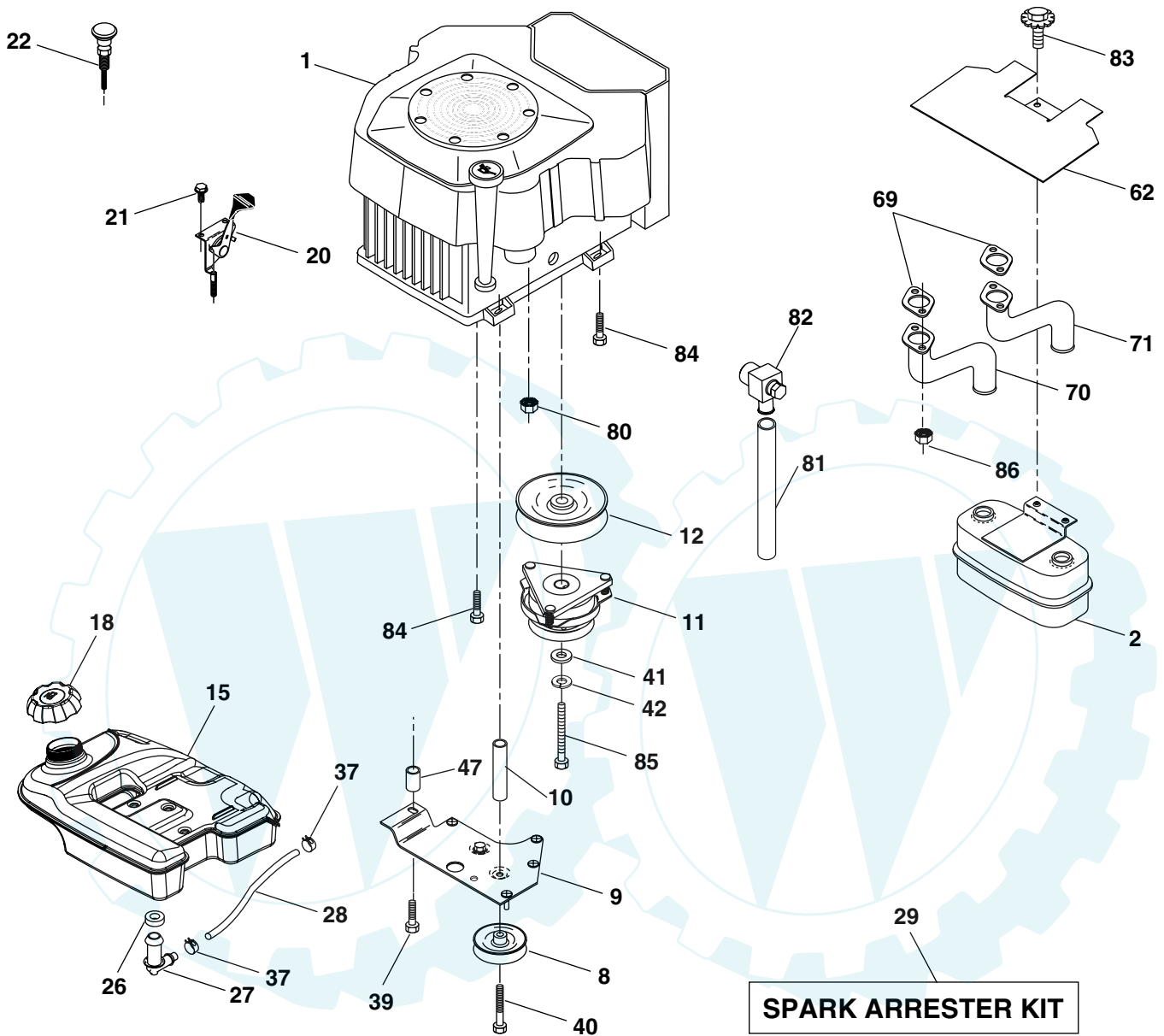

engine-kohler22\_17-vgt

# REPAIR PARTS

TRACTOR - - MODEL NO. GTH2548 (LOGT25H48B) PRODUCT NO. 954 57 21-34  
ENGINE

KEY NO.	PART NO.	DESCRIPTION
1	-----	Engine Kohler, Model No. CV730 (Order parts from engine manufacturer)
2	532 14 97-23	Muffler Side
8	532 12 13-61	Pulley V-Idler
9	532 17 77-48	Keeper Asm. Belt Engine VGT
10	532 17 52-87	Bushing
11	532 17 93-35	Clutch Electric
12	532 14 39-96	Pulley Engine VGT Elect Clutch
15	532 17 91-15	Tank Fuel Rear 5.0
18	532 18 18-03	Cap Fuel
20	532 18 29-37	Control Throttle
21	532 17 18-75	Screw Hwhd Hi-Lo #13-16 x 3/4
22	532 17 81-48	Control Choke
25	873 92 06-00	Nut Keps 3/8-24
26	532 12 49-52	Bushing
27	532 13 92-77	Stem Tank Fuel
28	532 12 47-03	Fuel Line
29	532 13 71-80	Spark Arrester Kit
31	532 14 50-06	Clip Push-In Hinged
37	532 12 34-87	Clamp Hose
39	817 49 06-36	Screw TT 3/8-16 x 2-1/4 unc
40	817 49 06-64	Screw TT 3/8-16 x 4 unc
41	532 12 61-97	Washer 1-1/2 OD X 15/32 ID X .250
42	810 04 07-00	Washer Lock 7/16
43	532 17 99-53	Bolt Hex 7/16-20 X 3.75 Ga. 5
47	532 17 52-88	Bushing
62	532 14 66-29	Shield Heat Muffler
69	532 18 60-54	Gasket
70	532 17 55-45	Tube Exhaust LH
71	532 17 55-46	Tube Exhaust RH
74	532 16 22-95	Elbow Street Brass
80	532 16 33-05	Nut Flange M8-1.25
81	<b>532 18 88-00</b>	Oil Drain Tube
82	<b>532 18 87-99</b>	Valve Drain Oil
83	532 17 18-77	Bolt 5/16-18 unc x 1-3/4 W/Sems
84	817 06 06-24	Screw 3/8-16 x 1-1/2
86	532 18 43-62	Nut Hex Flange Toplock M8-1.25

**NOTE:** All component dimensions given in U.S. inches  
1 inch = 25.4 mm

For engine service and replacement parts, call the toll free number for your engine manufacturer listed below:

Briggs & Stratton	1-800-233-3723
Kohler Co.	1-800-544-2444
Tecumseh Products	1-800-558-5402
Honda Engines	1-800-426-7701
Kawasaki	1-949-460-5688

# REPAIR PARTS

TRACTOR - - MODEL NO. GTH2548 (LOGT25H48B) PRODUCT NO. 954 57 21-34  
SEAT ASSEMBLY

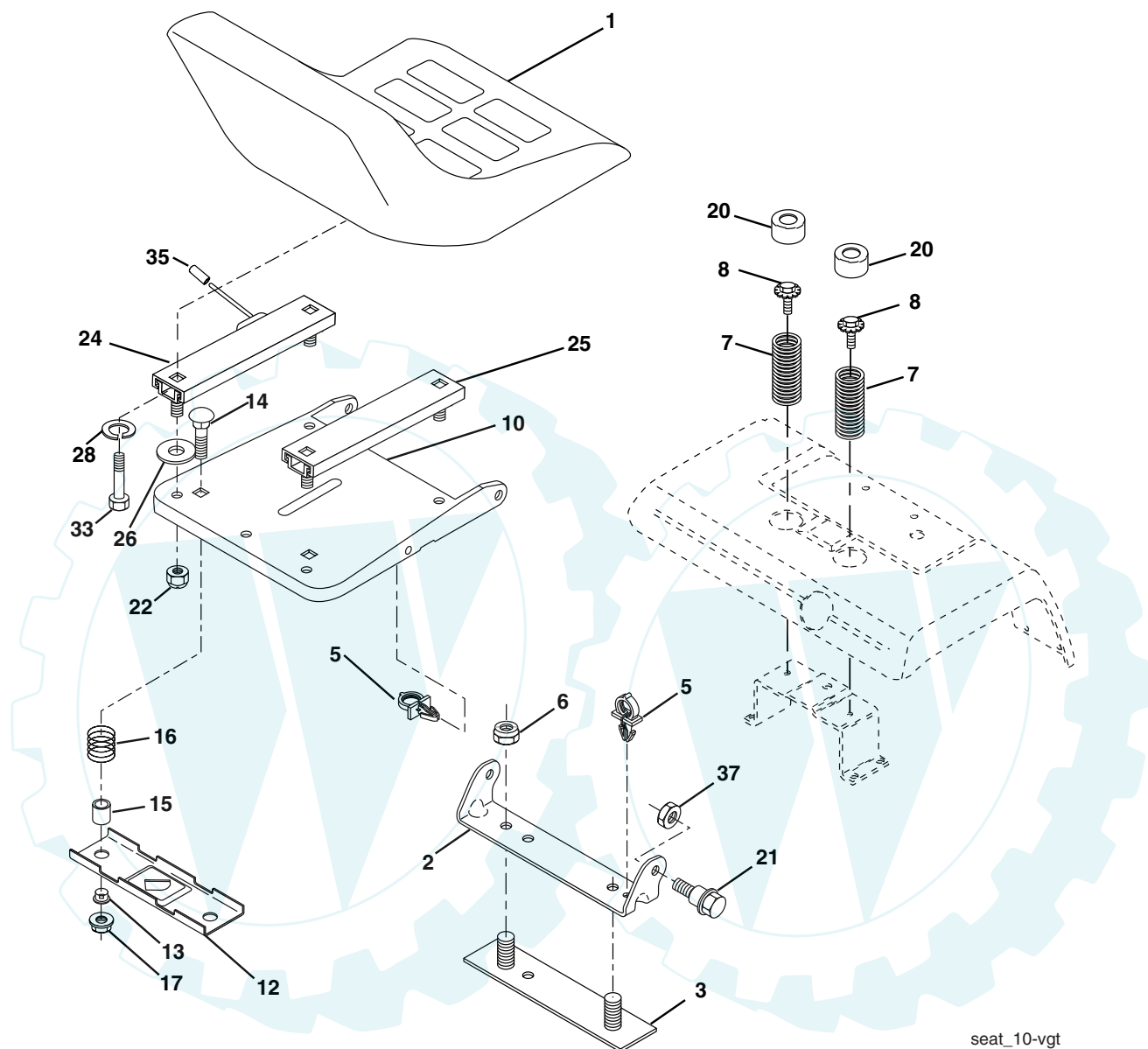

seat\_10-vgt

KEY NO.	PART NO.	DESCRIPTION
1	532 18 87-15	Seat
2	532 14 05-51	Bracket, Pivot Seat
3	532 14 06-75	Strap Asm Fender
5	532 14 50-06	Clip, Push In Hinged
6	873 80 06-00	Nut, Crownlock 3/8-16
7	532 12 41-81	Spring, Seat Cprsn
8	532 17 18-77	Bolt 5/16-18 Unc x 3/4
10	532 18 24-93	Pan, Seat
12	532 12 12-46	Bracket, Mounting Switch
13	532 12 12-48	Bushing, Snap
14	872 05 04-12	Bolt, Carriage 1/4-20 x 1-1/2
15	532 12 12-49	Spacer, Split
16	532 12 37-40	Spring, Cprsn

KEY NO.	PART NO.	DESCRIPTION
17	532 12 39-76	Nut, Lock 1/4 Lge Flg Gr. 5
20	532 12 42-38	Cap Spring Seat
21	532 17 18-52	Bolt, Shoulder 5/16-18
22	873 68 05-00	Nut Crown Lock 5/16-18
24	532 17 79-46	Track Slide Seat LH
25	532 17 79-47	Track Slide Seat RH
26	819 11 10-12	Washer 11/32 x 5/8 x 12 Ga.
28	810 01 05-00	Washer Split
33	874 78 05-12	Bolt Fin Hex 5/16-18 x 3/4
35	532 17 84-26	Cap Vinyl
37	873 80 05-00	Nut, Crownlock 5/16-18

**NOTE:** All component dimensions given in U.S. inches  
1 inch = 25.4 mm

# REPAIR PARTS

TRACTOR -- MODEL NO. GTH2548 (LOGT25H48B) PRODUCT NO. 954 57 21-34  
DECALS

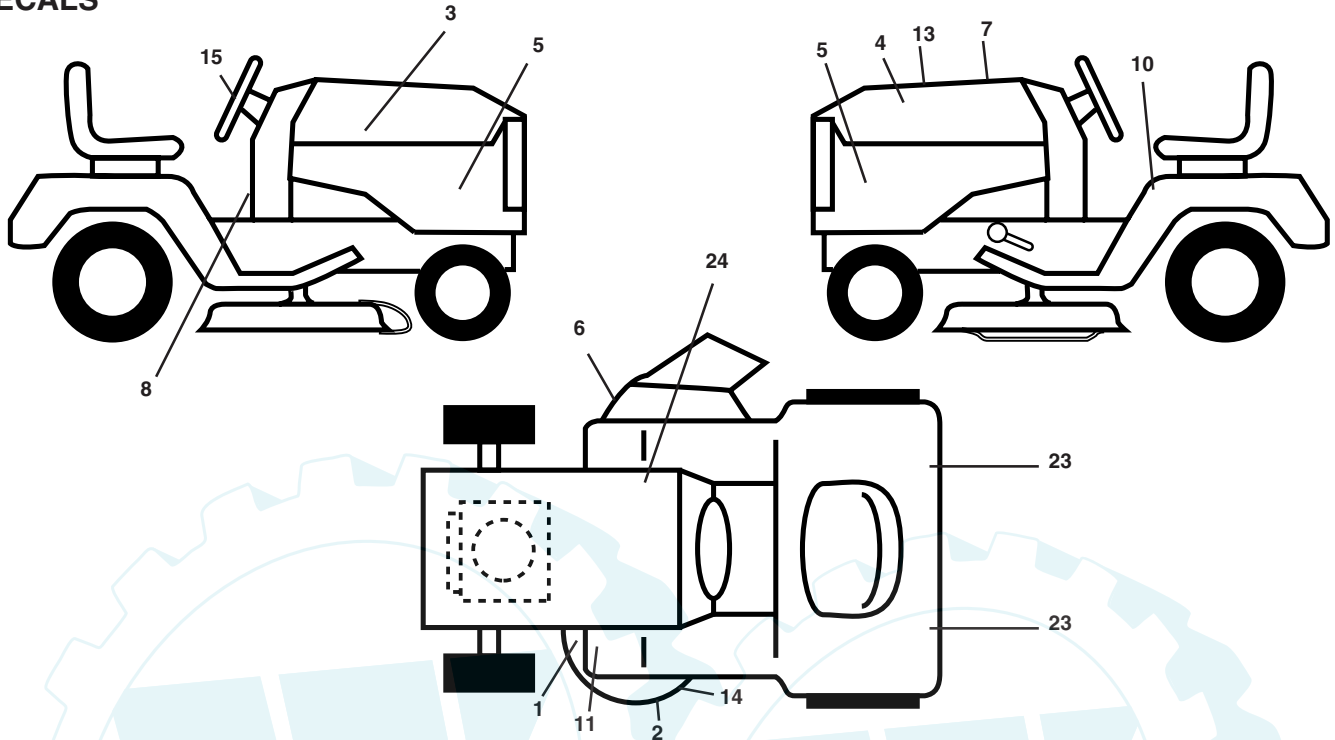

KEY NO.	PART NO.	DESCRIPTION
1	532 17 85-02	Decal, Deck Caution
2	532 17 84-82	Decal, Deck Hvy Duty
3	532 18 89-47	Decal, Hood RH
4	532 18 89-48	Decal, Hood LH
5	532 18 97-08	Decal, Side Panel
6	532 17 05-63	Decal, Warning
7	532 18 09-41	Decal, Cust. Resp.
8	532 18 28-54	Decal, Operator
10	532 15 71-40	Decal, Danger
11	532 18 12-53	Decal, Foot Rest

KEY NO.	PART NO.	DESCRIPTION
13	532 18 96-69	Decal, Replacement
14	532 17 52-91	Decal, V-Belt Schematic
15	532 18 89-25	Decal, Ins. Strg Whl
23	532 10 62-02	Reflector, Taillight LH/RH
24	532 14 50-05	Decal, Btry Dngr/Psn
--	532 16 69-60	Decal, Drawbar
--	532 18 19-17	Pad Footrest RH
--	532 18 19-16	Pad Footrest LH
--	<b>532 19 08-44</b>	Manual, Operator's (Eng.)

## WHEELS & TIRES

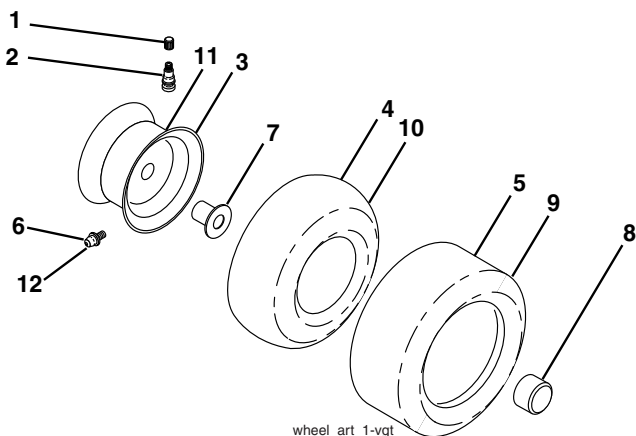

KEY NO.	PART NO.	DESCRIPTION
1	532 05 91-92	Cap, Valve, Tire
2	532 06 51-39	Stem, Valve
3	532 14 45-09	Rim Assembly, Front
4	532 00 81-34	Tube, Front (Service Item Only)
5	532 10 62-30	Tire, Front
6	532 12 49-57	Fitting, Grease
7	532 12 49-59	Bearing, Flange (Front Wheel Only)
8	532 17 50-39	Cap, Hub
9	532 10 55-88	Tire, Rear
10	532 00 71-54	Tube, Rear (Service Item Only)
11	532 14 45-10	Rim Assembly, Rear
12	532 12 48-60	Fitting, Grease
--	532 14 43-34	Sealant, Tire (10 oz. Tube)

**NOTE:** All component dimensions given in U.S. inches  
1 inch = 25.4 mm

# REPAIR PARTS

TRACTOR - - MODEL NO. GTH2548 (LOGT25H48B) PRODUCT NO. 954 57 21-34  
LIFT ASSEMBLY

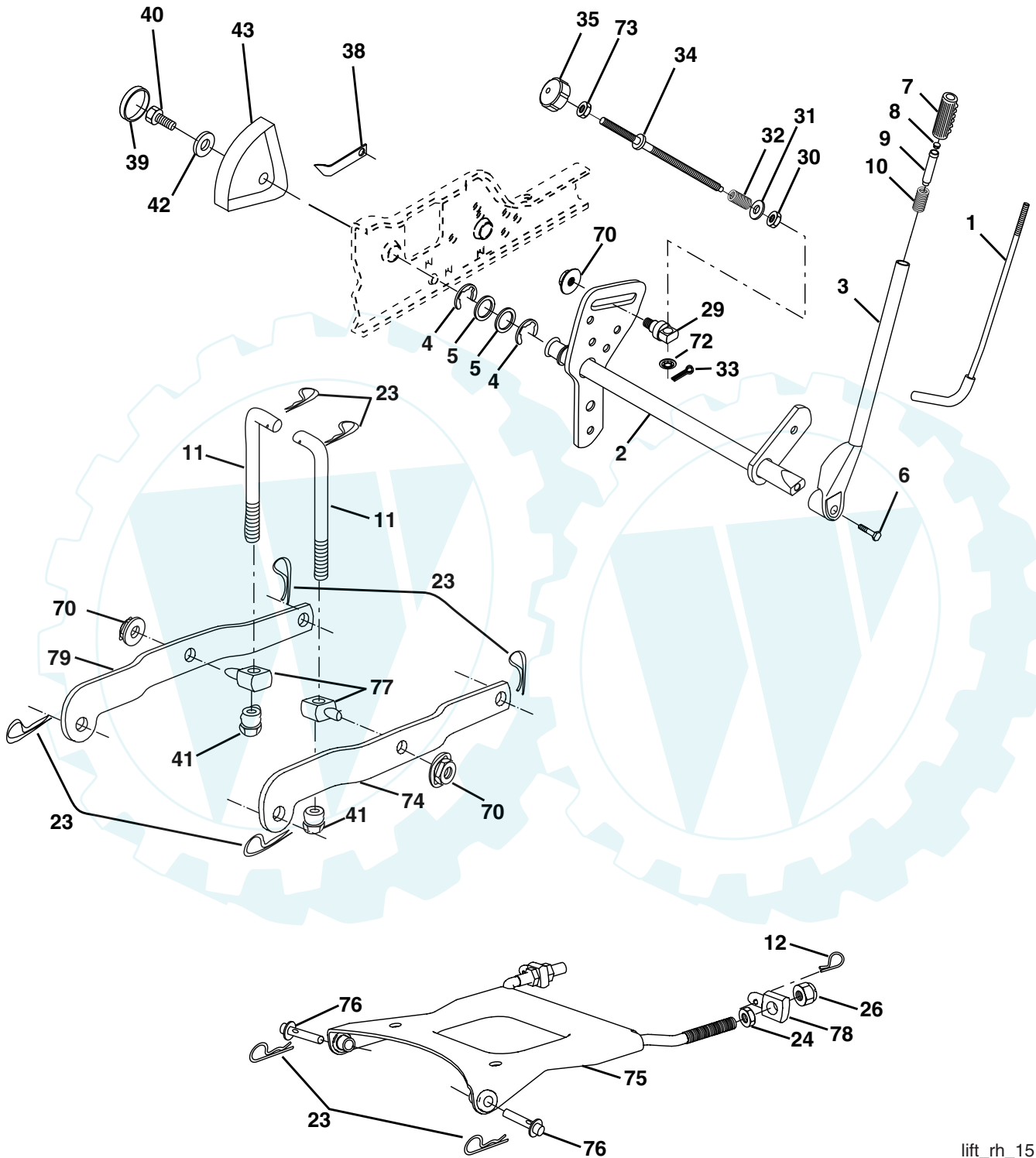

lift\_rh\_15



## REPAIR PARTS

TRACTOR - - MODEL NO. GTH2548 (LOGT25H48B) PRODUCT NO. 954 57 21-34  
LIFT ASSEMBLY

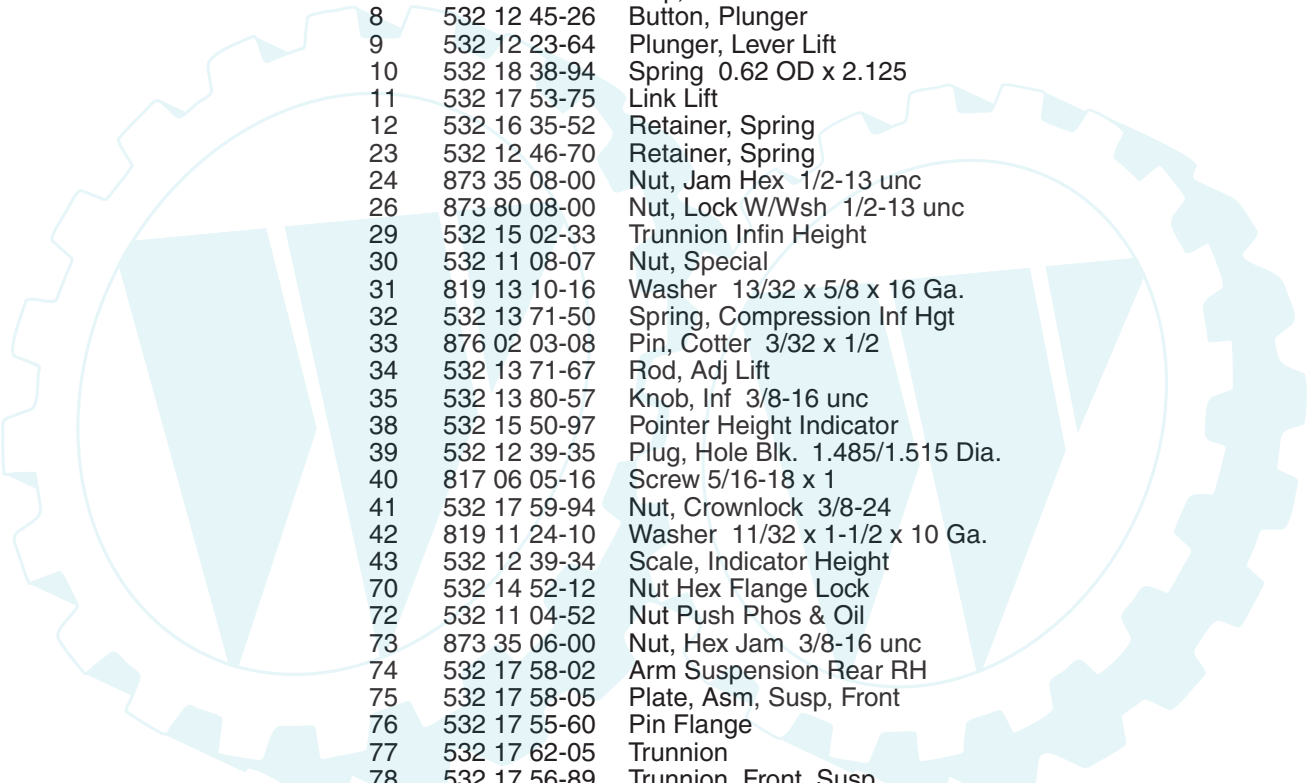

KEY NO.	PART NO.	DESCRIPTION
1	532 12 10-06	Rod Asm., Lever
2	532 18 00-45	Shaft Asm., Lift Vgt
3	532 15 91-89	Lever Asm., Lift Rh
4	812 00 00-22	E-Ring Truarc #5133-87
5	819 29 20-16	Washer 29/32 x 1-1/4 x 16 Ga.
6	871 11 06-24	Bolt, Fin Hex 3/8-16 x 1-1/2
7	532 12 56-31	Grip, Handle
8	532 12 45-26	Button, Plunger
9	532 12 23-64	Plunger, Lever Lift
10	532 18 38-94	Spring 0.62 OD x 2.125
11	532 17 53-75	Link Lift
12	532 16 35-52	Retainer, Spring
23	532 12 46-70	Retainer, Spring
24	873 35 08-00	Nut, Jam Hex 1/2-13 unc
26	873 80 08-00	Nut, Lock W/Wsh 1/2-13 unc
29	532 15 02-33	Trunnion Infin Height
30	532 11 08-07	Nut, Special
31	819 13 10-16	Washer 13/32 x 5/8 x 16 Ga.
32	532 13 71-50	Spring, Compression Inf Hgt
33	876 02 03-08	Pin, Cotter 3/32 x 1/2
34	532 13 71-67	Rod, Adj Lift
35	532 13 80-57	Knob, Inf 3/8-16 unc
38	532 15 50-97	Pointer Height Indicator
39	532 12 39-35	Plug, Hole Blk. 1.485/1.515 Dia.
40	817 06 05-16	Screw 5/16-18 x 1
41	532 17 59-94	Nut, Crownlock 3/8-24
42	819 11 24-10	Washer 11/32 x 1-1/2 x 10 Ga.
43	532 12 39-34	Scale, Indicator Height
70	532 14 52-12	Nut Hex Flange Lock
72	532 11 04-52	Nut Push Phos & Oil
73	873 35 06-00	Nut, Hex Jam 3/8-16 unc
74	532 17 58-02	Arm Suspension Rear RH
75	532 17 58-05	Plate, Asm, Susp, Front
76	532 17 55-60	Pin Flange
77	532 17 62-05	Trunnion
78	532 17 56-89	Trunnion, Front, Susp
79	532 17 53-78	Arm, Suspension Rear LH

**NOTE:** All component dimensions given in U.S. inches  
1 inch = 25.4 mm

# REPAIR PARTS

TRACTOR - - MODEL NO. GTH2548 (LOGT25H48B) PRODUCT NO. 954 57 21-34  
MOWER DECK

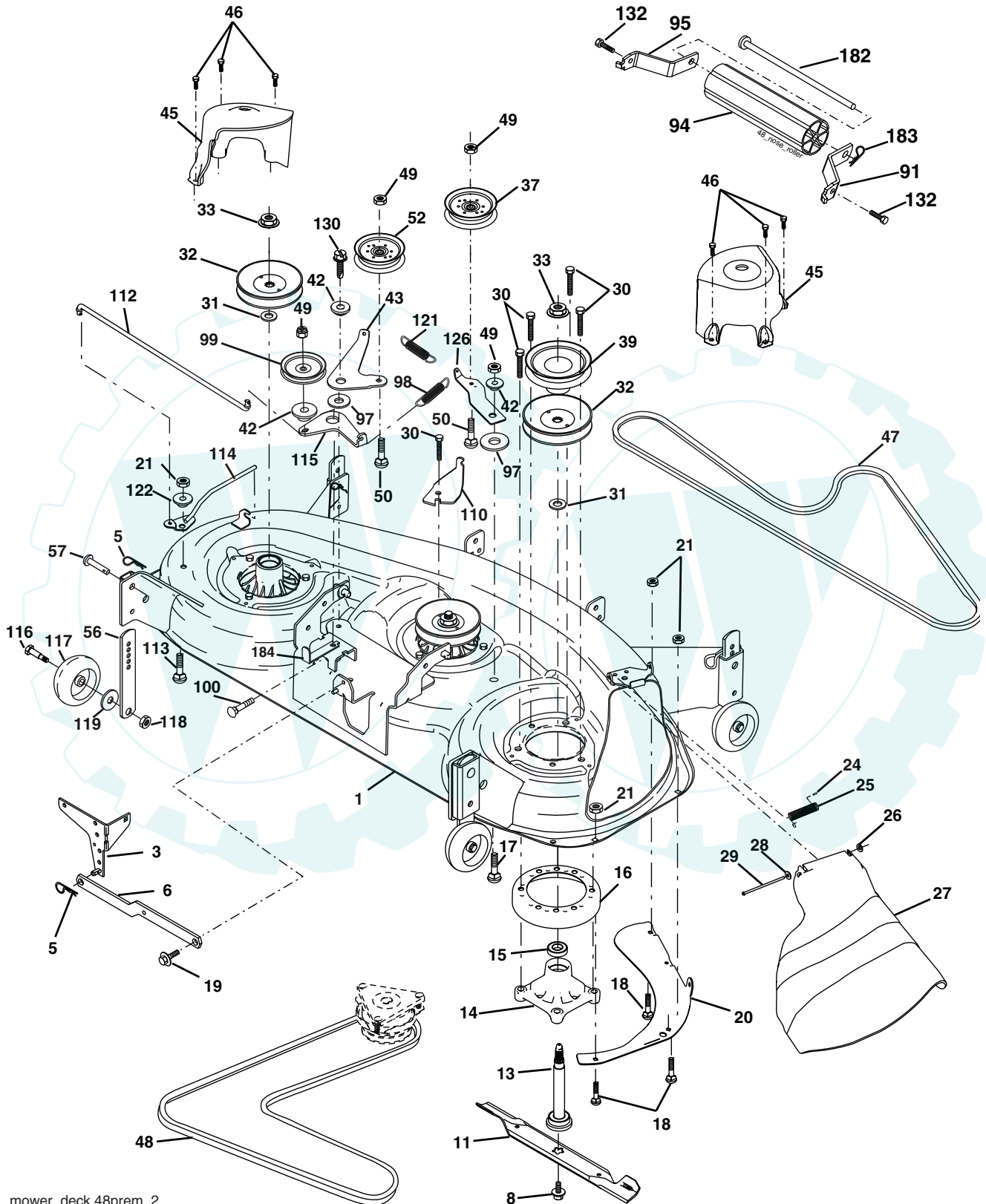

mower\_deck.48prem\_2

# REPAIR PARTS

## TRACTOR - - MODEL NO. GTH2548 (LOGT25H48B) PRODUCT NO. 954 57 21-34 MOWER DECK

KEY NO.	PART NO.	DESCRIPTION	KEY NO.	PART NO.	DESCRIPTION
1	532 18 03-58	Deck Weldment Mower 48	56	532 15 59-86	Bar Pnt Adj.
3	532 17 89-15	Bracket Asm., Sway Bar	57	532 15 69-41	Pin Head Rivet
5	532 12 46-70	Retainer Spring	91	532 18 05-35	Bracket Asm N Roller RH
6	532 17 80-24	Bar Sway Deck	94	532 17 60-66	Roller Nose 48"
8	532 17 43-65	Bolt 7/16 Asm. Blade	95	532 18 05-34	Bracket Asm N Roller LH
11	532 18 00-54	Blade	97	532 17 85-15	Washer Hardened
13	532 17 43-60	Shaft Asm. w/Lower Bearing	98	532 17 94-79	Spring Primary Drive
14	532 17 43-58	Mandrel Asm.	99	532 18 40-58	Pulley Idler"V"
15	532 11 04-85	Bearing, Ball, Mandrel	100	872 11 06-16	Bolt RDHD Sqnk 3/8-16 unc x 2
16	532 17 44-93	Stripper Mandrel Deck	110	532 17 50-16	Arm Spring Secondary
17	872 11 06-10	Bolt RDHD Sq Neck 3/8-16 x 1.25	112	532 17 43-87	Link Tension Relief Lever
18	872 14 05-05	Bolt, Carriage 5/16-18 x 5/8	113	872 11 05-06	Bolt Carr. 5/16-18 x 3/4
19	532 13 28-27	Bolt, Hex Hd, Shoulder 5/16-18	114	532 17 43-84	Tension Asm. Relief Lever
20	532 17 43-78	Baffle, Vortex Mower	115	532 17 46-09	Arm Spring Tension Relief
21	873 68 05-00	Nut, Crownlock 5/16-18 unc	116	532 18 42-19	Bolt Shoulder
24	532 10 53-04	Cap, Sleeve	117	532 13 39-57	Gauge Wheel
25	532 17 81-02	Spring, Torsion	118	873 93 06-00	Nut, Centerlock 3/8-16 unc
26	532 11 04-52	Nut, Push	119	819 12 14-14	Washer 3/8 x 7/8 x 14 Ga.
27	532 18 17-07	Deflector Shield	121	532 17 43-71	Spring Secondary Drive
28	819 11 10-16	Washer 11/32 x 5/8 x 16 Ga.	122	532 17 46-06	Bushing Pivot Tension Relief
29	532 13 14-91	Rod, Hinge	126	532 17 43-72	Arm, Idler, Primary Deck
30	532 17 39-84	Screw, Thdroll Washer Head	130	817 00 06-16	Screw 3/8-16 x 1.0
31	532 18 76-90	Washer, Spacer	132	817 00 06-12	Screw 3/8-16 x 3/4
32	<b>532 17 34-36</b>	Pulley, Mandrel	182	532 17 91-27	Rod Roller Nose
33	532 17 83-42	Nut, Flg. Top Lock Cntr. 9/16	183	532 16 35-52	Retainer Spring
37	532 17 79-68	Pulley, Idler, Flat	184	532 17 39-79	Keeper Belt Idler
39	532 17 43-75	Pulley, Idler, Driven	--	532 17 43-56	Mandrel Asm. Service (Includes Key Nos. 13-15 and 33)
42	<b>532 12 20-52</b>	Spacer, Retainer	--	532 18 15-91	Replacement Mower, Complete (Std. Deck-Order separately nose roller components key nos. 91, 94, 95, 132, 182 and 183)
43	532 17 43-73	Arm, Idler Secondary			
45	532 18 08-06	Cover, Mandrel Deck			
46	532 13 77-29	Screw, Thdroll. 1/4-20 x 5/8			
47	532 18 08-08	V-Belt, Mower, Secondary			
48	532 17 43-68	V-Belt, Mower, Primary			
49	<b>873 90 06-00</b>	Nut, Lock 3/8-16 unc			
50	872 11 06-12	Bolt, Carr. 3/8-16 x 1-1/2 Gr. 5			
52	532 17 58-20	Pulley Idler Flat			

**NOTE:** All component dimensions given in U.S. inches  
1 inch = 25.4 mm